



*Dept. of Electronics & Communication
Engineering*

Harbin Institute of Technology

Harbin 150001, P.R. China

E-mail: qw@hit.edu.cn

Tel. +86 451 6413502

移动通信终端天线设计 (3)

吴群

教授，工学博士



哈爾濱工業大學

Antenna related parts and connectors



Connector R&D

Features

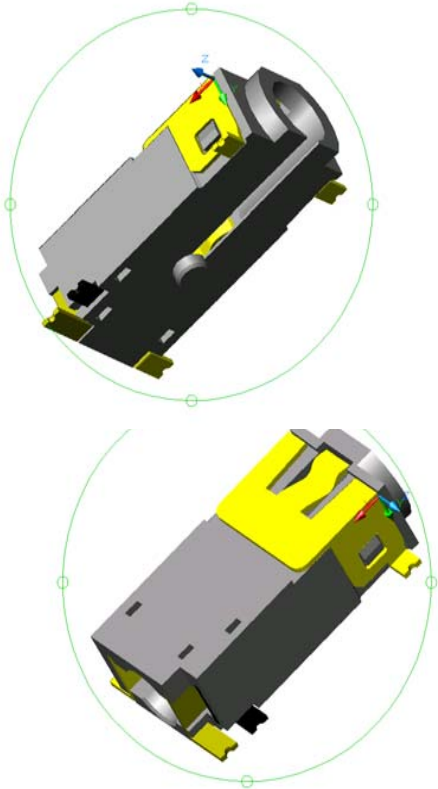

- From 4 up to 7 contacts
- Float Mounting
- Switch by plug
- Simplifies alignment into the system
- Contact force on PCB : 0,35 N mini
- Allow to connect headset and/or charger in one connector
- Customized and polarized charger side

Allowed design range: from 6 to 12 contacts with 1,4 mm pitch

Flat plug Technology



Connector R&D

Features

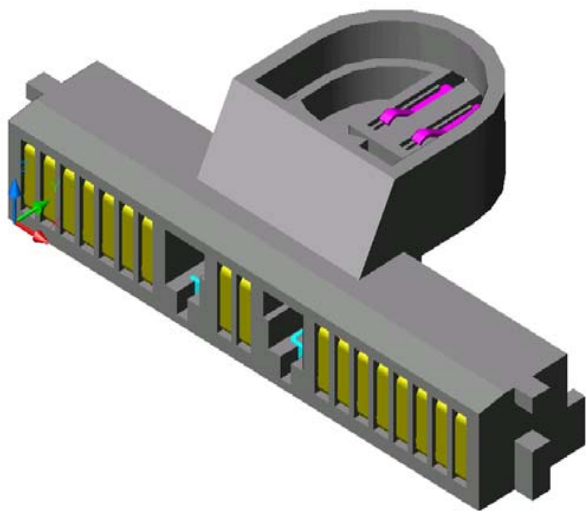

- From 4 up to 7 contacts
- Float Mounting
- Switch by plug
- Simplifies alignment into the system
- Contact force on PCB : 0,35 N mini
- Allow to connect headset and/or charger in one connector
- Customized and polarized charger side

Allowed design range: from 6 to 12 contacts with 1,4 mm pitch

Flat plug Technology



RF Switch

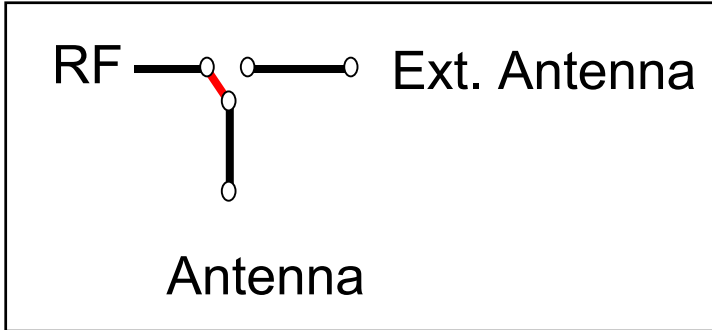

Functions

- Switching : mechanical side
- Wave transmission : RF behaviour

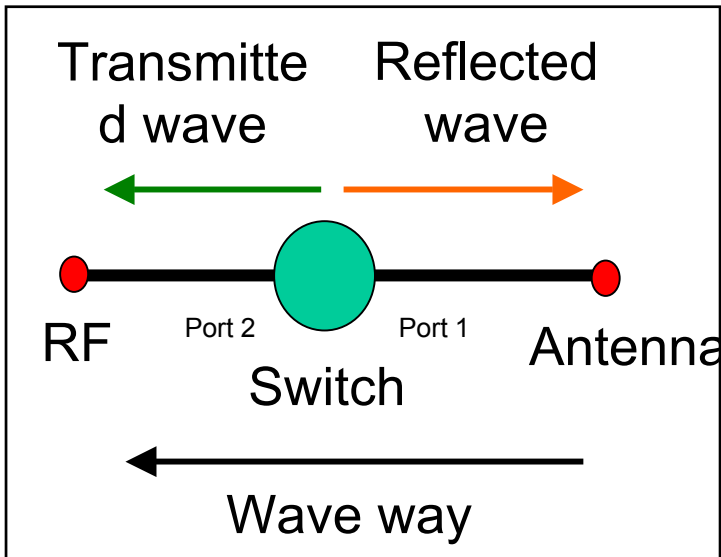

Requirements

- RF switch is a discontinuity on the wave line = signal disturbances
- Target: decrease to minimum this disturbances
- Adapted working at different wavelenths



RF Switch

architecture

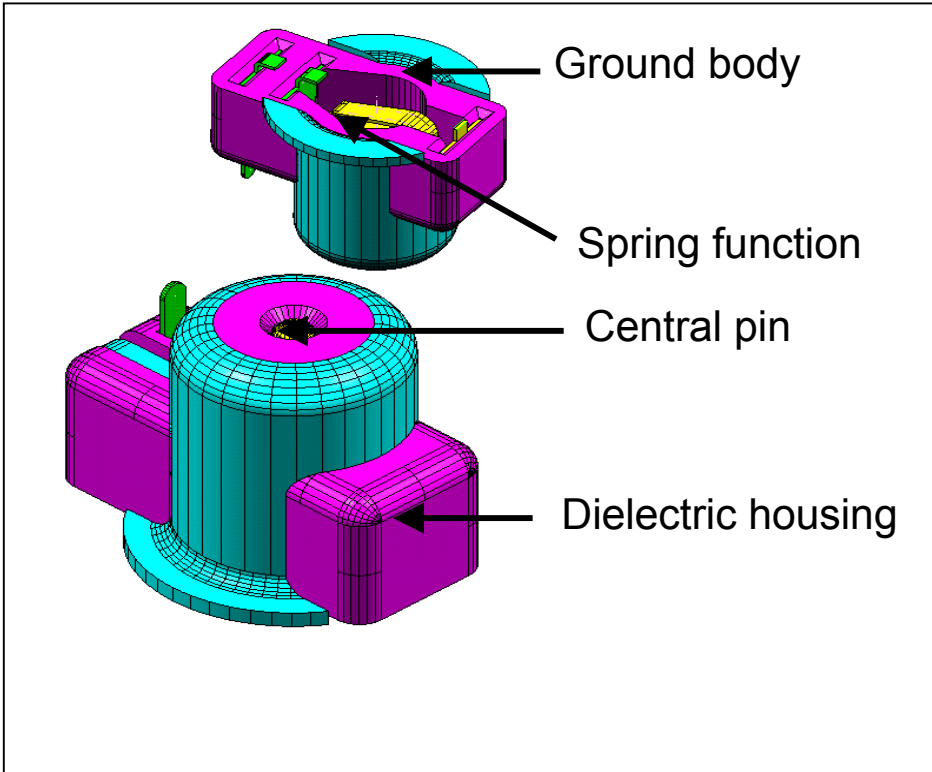



RF Switch

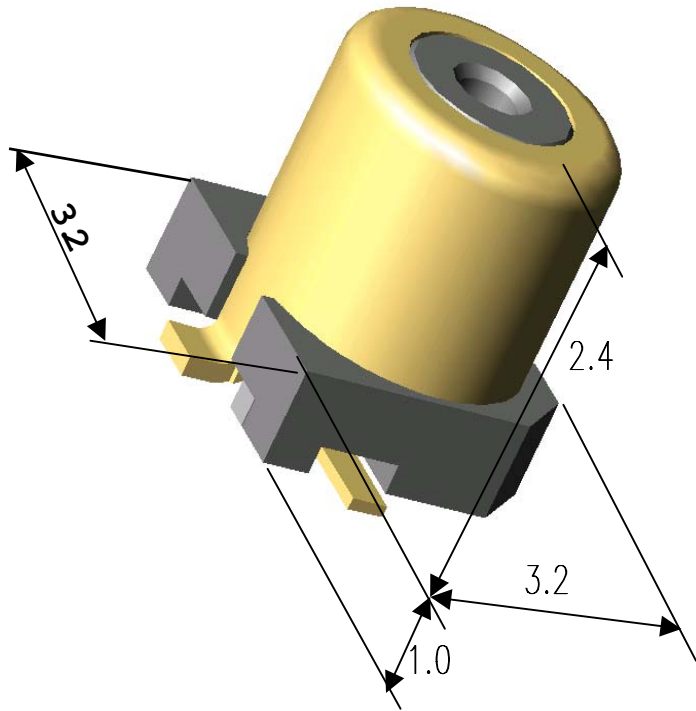

architecture

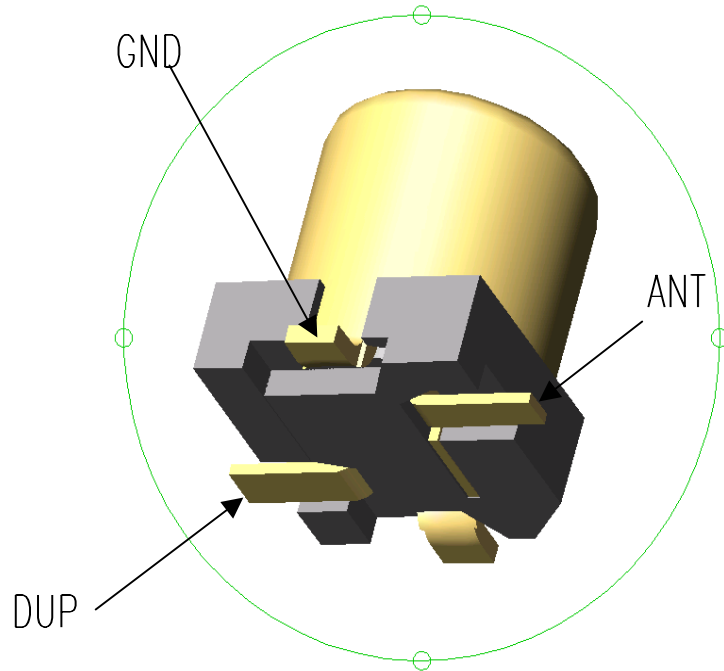



RF Switch

Characterization parameters

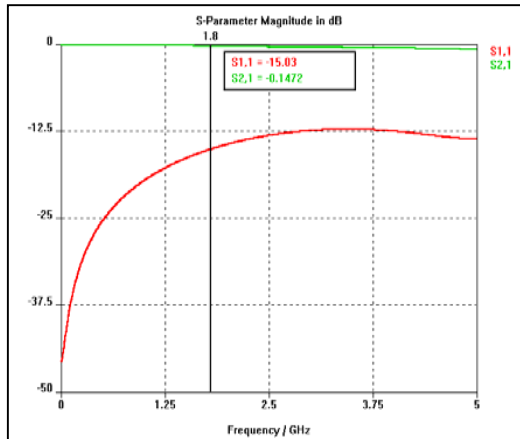
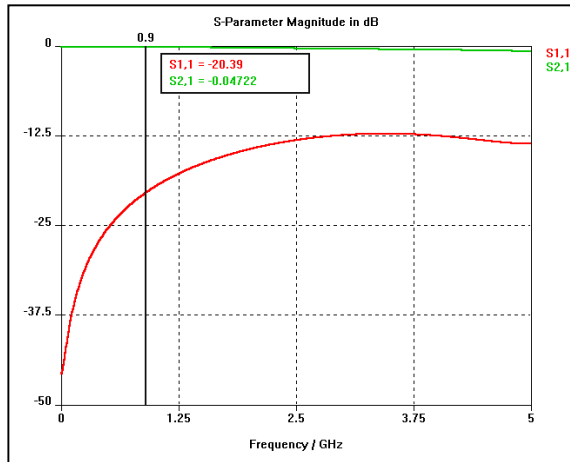

Click to enhance

- S parameters : S_{11} for reflection, S_{21} for transmission (dB)

$$S_{i1} = f(\lambda)$$

- Reflection parameter : VSWR

$$VSWR = (1 + |S_{11}|) / (1 - |S_{11}|)$$

- Transmission parameter: Insertion loss

$$IL = 10 \cdot \text{Log}(1 / |S_{21}|^2)$$

- Insulation between signal and ground strips : high frequencies
- Switch impedance (Z) must reach the board one
→ less misadaptation



RF Switch

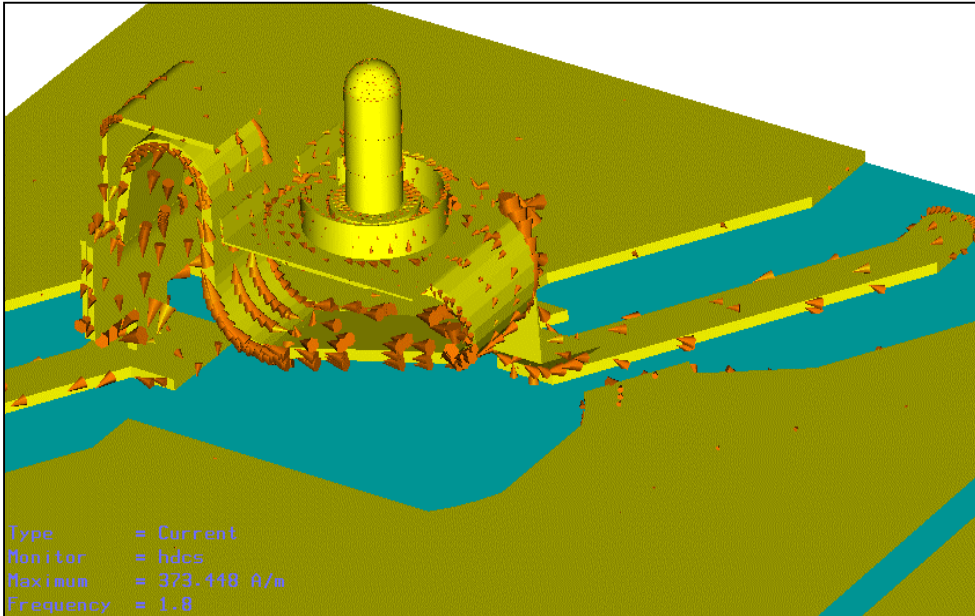

Reaching RF features

- Design and prototyping: measurement by a network analyzer
- RF simulation in design step: recommended for complex products



RF Switch



Float switch

- Switch function on antenna contact
- Inserted directly in the phone frame
- Machined technology
- 4 versions available
- High assembly rate, fully automated

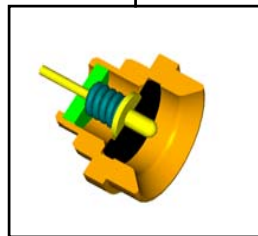



RF Switch

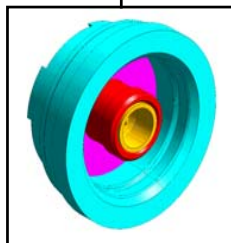

Waterproof switch

- **Waterproof under 2 meters**
- **All machined parts**
- **Radial displacement**
- **SMT technology**
- **Adapted for low quantities, few investments**
- **Ability for specific outer design**



RF Switch

Stamped + DAC

Cette étude est la propriété de la société
Amphenol Socapex et ne peut être divulguée
sans son autorisation écrite.
This study belongs to Amphenol Socapex and can't be
disclosed to third parties without authorization from
Amphenol Socapex

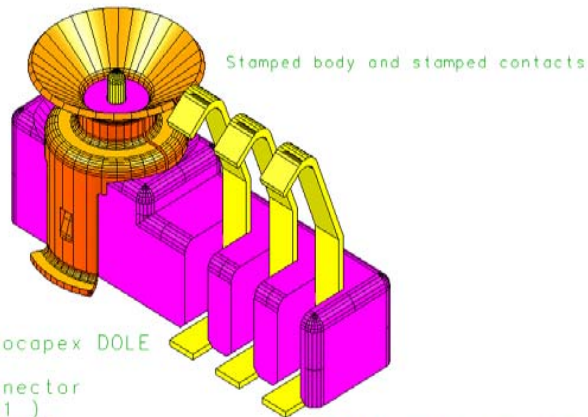

Amphenol Socapex DOLE

Switch Connector
(ET757301)
BP 1e 02/05/00

EPA00-22-doc01 ed.A

- Stamped body
- High temperature plastic frame
- Direct Antenna Contacts, inserted
- SMT technology



RF Switch

MID switch

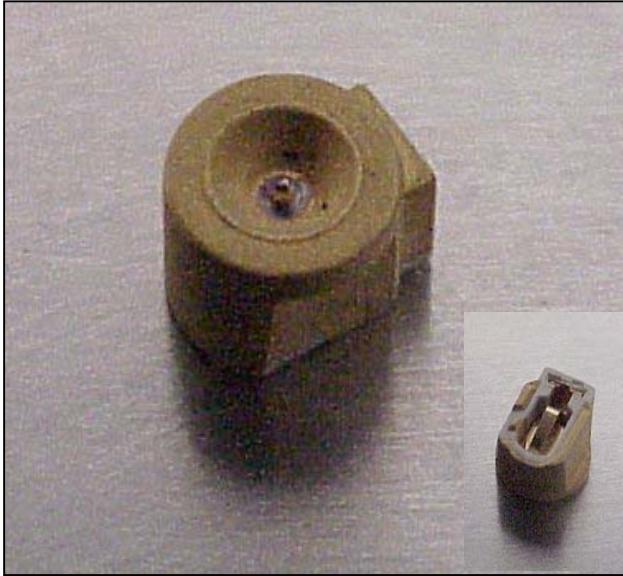

- New technology to reduce the number of spare parts to 2 or 3
- Two shots molding and metallized body
- Overall dimensions: 5,5 x 5 x 3,5 mm
- Adaptable to any external design, by changing the interface cavity

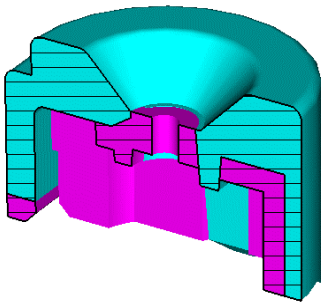

Body structure



Antennas design EDA

Electromagnetic modeling

- IE3D Zealand (Planar structures)
- NEC2 LLNL (Wires only)
- HFSS Ansoft (Full 3D)
- FD-TD Internally developed SAR Calculations

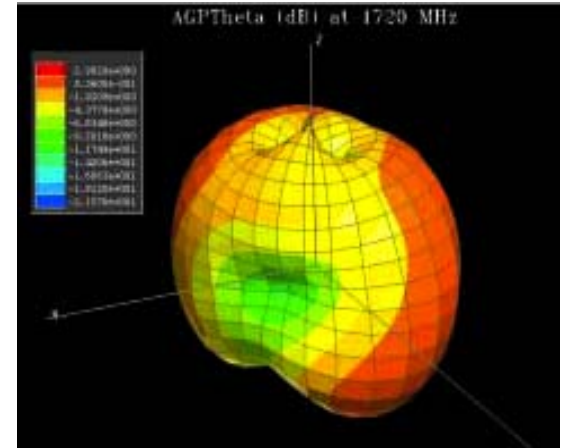
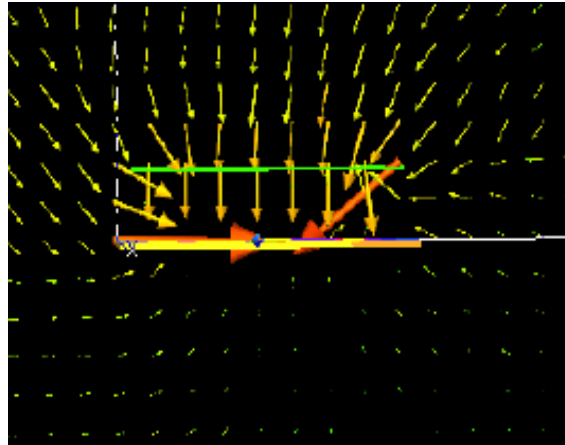
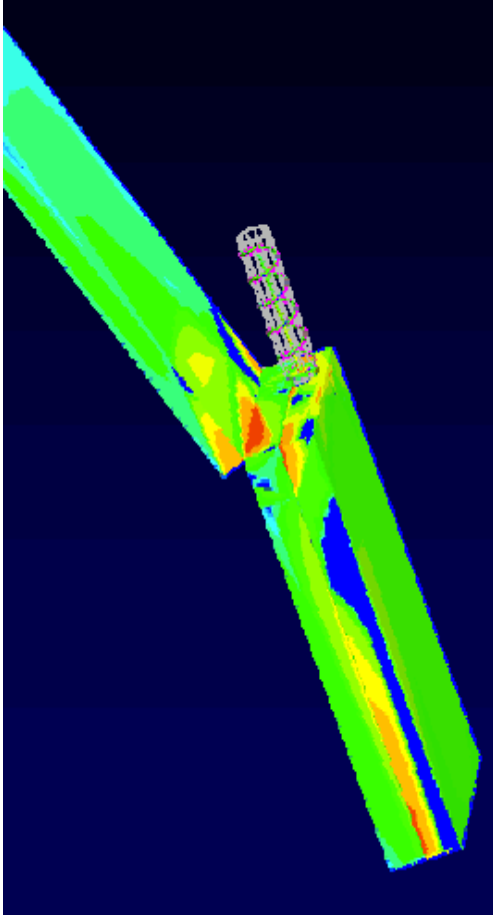

射频和天线设计培训课程推荐

易迪拓培训(www.edatop.com)由数名来自于研发第一线的资深工程师发起成立,致力并专注于微波、射频、天线设计研发人才的培养;我们于 2006 年整合合并微波 EDA 网(www.mweda.com),现已发展成为国内最大的微波射频和天线设计人才培养基地,成功推出多套微波射频以及天线设计经典培训课程和 ADS、HFSS 等专业软件使用培训课程,广受客户好评;并先后与人民邮电出版社、电子工业出版社合作出版了多本专业图书,帮助数万名工程师提升了专业技术能力。客户遍布中兴通讯、研通高频、埃威航电、国人通信等多家国内知名公司,以及台湾工业技术研究院、永业科技、全一电子等多家台湾地区企业。

易迪拓培训课程列表: <http://www.edatop.com/peixun/rfe/129.html>



射频工程师养成培训课程套装

该套装精选了射频专业基础培训课程、射频仿真设计培训课程和射频电路测量培训课程三个类别共 30 门视频培训课程和 3 本图书教材;旨在引领学员全面学习一个射频工程师需要熟悉、理解和掌握的专业知识和研发设计能力。通过套装的学习,能够让学员完全达到和胜任一个合格的射频工程师的要求...

课程网址: <http://www.edatop.com/peixun/rfe/110.html>

ADS 学习培训课程套装

该套装是迄今国内最全面、最权威的 ADS 培训教程,共包含 10 门 ADS 学习培训课程。课程是由具有多年 ADS 使用经验的微波射频与通信系统设计领域资深专家讲解,并多结合设计实例,由浅入深、详细而又全面地讲解了 ADS 在微波射频电路设计、通信系统设计和电磁仿真设计方面的内容。能让您在最短的时间内学会使用 ADS,迅速提升个人技术能力,把 ADS 真正应用到实际研发工作中去,成为 ADS 设计专家...



课程网址: <http://www.edatop.com/peixun/ads/13.html>



HFSS 学习培训课程套装

该套课程套装包含了本站全部 HFSS 培训课程,是迄今国内最全面、最专业的 HFSS 培训教程套装,可以帮助您从零开始,全面深入学习 HFSS 的各项功能和在多个方面的工程应用。购买套装,更可超值赠送 3 个月免费学习答疑,随时解答您学习过程中遇到的棘手问题,让您的 HFSS 学习更加轻松顺畅...

课程网址: <http://www.edatop.com/peixun/hfss/11.html>

CST 学习培训课程套装

该培训套装由易迪拓培训联合微波 EDA 网共同推出,是最全面、系统、专业的 CST 微波工作室培训课程套装,所有课程都由经验丰富的专家授课,视频教学,可以帮助您从零开始,全面系统地学习 CST 微波工作的各项功能及其在微波射频、天线设计等领域的设计应用。且购买该套装,还可超值赠送 3 个月免费学习答疑...

课程网址: <http://www.edatop.com/peixun/cst/24.html>



HFSS 天线设计培训课程套装

套装包含 6 门视频课程和 1 本图书,课程从基础讲起,内容由浅入深,理论介绍和实际操作讲解相结合,全面系统的讲解了 HFSS 天线设计的全过程。是国内最全面、最专业的 HFSS 天线设计课程,可以帮助您快速学习掌握如何使用 HFSS 设计天线,让天线设计不再难...

课程网址: <http://www.edatop.com/peixun/hfss/122.html>

13.56MHz NFC/RFID 线圈天线设计培训课程套装

套装包含 4 门视频培训课程,培训将 13.56MHz 线圈天线设计原理和仿真设计实践相结合,全面系统地讲解了 13.56MHz 线圈天线的工作原理、设计方法、设计考量以及使用 HFSS 和 CST 仿真分析线圈天线的具体操作,同时还介绍了 13.56MHz 线圈天线匹配电路的设计和调试。通过该套课程的学习,可以帮助您快速学习掌握 13.56MHz 线圈天线及其匹配电路的原理、设计和调试...

详情浏览: <http://www.edatop.com/peixun/antenna/116.html>



我们的课程优势:

- ※ 成立于 2004 年,10 多年丰富的行业经验,
- ※ 一直致力并专注于微波射频和天线设计工程师的培养,更了解该行业对人才的要求
- ※ 经验丰富的一线资深工程师讲授,结合实际工程案例,直观、实用、易学

联系我们:

- ※ 易迪拓培训官网: <http://www.edatop.com>
- ※ 微波 EDA 网: <http://www.mweda.com>
- ※ 官方淘宝店: <http://shop36920890.taobao.com>