



# **Test Plan for RF Performance Evaluation of Wi-Fi Mobile Converged Devices**

**Version 1.3  
June 2009**

© 2006 CTIA – The Wireless Association (CTIA) and Wi-Fi Alliance (WFA). All rights reserved. CTIA and WFA have granted a license to Authorized Testing Laboratories to use this Test Plan for the sole purpose of testing wireless products for their respective Certification Programs. Any reproduction or transmission of all or part of this Test Plan, in any form or by any means, electronic or mechanical, including photocopying, recording, or any information CTIA and WFA is unauthorized and strictly prohibited. Test laboratories that are not Authorized Testing Laboratories that wish to use this test Plan must receive written permission from CTIA and WFA prior to such use.

Interested parties may obtain permission to reproduce a limited number of copies by contacting CTIA or Wi-Fi Alliance at:

CTIA - The Wireless Association  
1400 16th Street, NW  
Suite 600  
Washington, DC 20036  
Phone: 1.202.785.0081  
Fax: 1.202.466.3413  
Email: certification@ctia.org

© Wi-Fi Alliance  
3925 West Braker Lane  
Austin, TX 78729  
Phone: 1.512.305.0790  
Fax: 1.512.305.0791  
Email: certifications@wi-fi.org

**Acknowledgments:**

This test plan was created by the wireless industry with input from the following companies and their representatives:

<b>Company</b>	<b>Representative</b>
Azimuth Systems	Charles Wright
CETECOM, Inc	Lothar Schmidt
Cingular	Jason Brown
DSP Group	Graham Smith
ETS-Lindgren	Dr. Michael Foegelle
Ixia	Larry Green
Nokia Mobile Phones, Inc.	Alan Ewing
	Steve Wilhoff
Philips Semiconductor	Steve Shearer
Sprint	Alex Tkatch
Telecommunications Metrology Center of China Ministry of Information Industry	Gao Hong
Wi-Fi Alliance	Patrick Green

## Change History

Version	Date	Comments
1.0	08-Aug-2006	Document Approved
1.1	20-Aug-2007	<ul style="list-style-type: none"> <li>• Updated Purpose and References sections</li> <li>• Clarified text and added footnote in Radiated RF Tests nomenclature section</li> <li>• Clarified text in Minimum Measurement Distance section</li> <li>• Clarified testing conditions for cellular inactive state</li> <li>• Corrected step reference in step 14 of Receive Sensitivity Measurement. Removed repeated text.</li> <li>• Removed reference to CTIA website for traffic generator software download</li> <li>• Corrected step 1 and clarified language in step 9 regarding antenna connection in WLAN Access Point Testing Methodology section</li> <li>• Removed requirement for OFMD transmit mask test on Mobile Stations and Access Points</li> <li>• Updated WLAN Test Set Estimated Signal Level tables</li> <li>• Added Sample Summation test report table</li> <li>• Corrected title on Test 5.2.2. and 6.2.2 test report table</li> <li>• Added text to clarify that Wi-Fi desense testing is done in free-space only</li> <li>• Clarified that cellular desense testing is done in free-space only, and to perform reference measurements if not previously done</li> <li>• Removed references to specific test equipment from document</li> </ul>
1.2	26-June-2008	<ul style="list-style-type: none"> <li>• 5 GHz TRP, TIS, &amp; Reference Measurement frequency changes – Sections 5.1.1.2, 5.1.2.2, 5.2.1.2, 5.2.2.2, Table 5.2 5, 6.1.1.2, 6.1.2.2, 6.2.1.2, 6.2.2.2, Table B2 , Table B3, Table B4, Table B5, Table B6, Table B7, New Appendix D</li> <li>• Other sections changed: Table B1 - CID Added, section 1.4 - CTIA Reference updated, Table A1 Channel change UTRA FDD Band I - IV, 4120/824.0 changed to 4132/826.4, Table B3 Reference changed from (2) to (1), Table 5.1.1 and table 6.1.1 - removed "Check TX Mask" from comments column</li> </ul>
1.3	16 June, 2009	<ul style="list-style-type: none"> <li>• Added footnote to Section 1.2, 3<sup>rd</sup> sentence</li> <li>• Added text to Section 4.1, 2<sup>nd</sup> sentence</li> <li>• Added CTIA Request # to Appendix B table</li> <li>• Added Appendix E Device Capabilities Testing Matrix</li> </ul>

## Table of Contents

1.	Introduction .....	9
1.1	Background .....	9
1.2	Scope .....	9
1.3	Purpose .....	9
1.4	References .....	9
1.5	Test Nomenclature Overview .....	10
1.5.1	Radiated RF Tests .....	10
1.5.2	Conducted RF Tests .....	10
1.6	Characterization of Measurements .....	10
1.6.1	Measurement Techniques .....	10
1.6.2	Measurement Uncertainty .....	10
1.6.3	Minimum Measurement Distance .....	11
1.6.4	Equipment Required .....	11
1.6.5	Quiet Zone Test Frequencies .....	11
2.	WLAN Client Testing Methodology .....	12
2.1	WLAN Test Set .....	13
2.2	Conducted RF Tests .....	14
2.2.1	Test Set-up .....	14
2.2.2	Transmit Power Measurement .....	14
2.2.2.1	Discussion .....	14
2.2.2.2	Unicast Test Packets .....	14
2.2.2.3	Test Procedure .....	15
2.2.2.4	Results .....	15
2.2.3	Receive Sensitivity Measurement .....	15
2.2.3.1	Discussion .....	15
2.2.3.2	Unicast Test Packets .....	16
2.2.3.3	Test Procedure .....	16
2.2.3.4	Results .....	16
2.3	Radiated RF Tests .....	17
2.3.1	Test Set-up .....	17
2.3.2	Radiated Power .....	17
2.3.2.1	Discussion .....	17
2.3.2.2	Unicast Test Packets .....	17
2.3.2.3	Test Procedure .....	17
2.3.2.4	Results .....	18
2.3.3	Receive Sensitivity Measurement .....	18
2.3.3.1	Discussion .....	18
2.3.3.2	Unicast Test Packets .....	19
2.3.3.3	Procedure .....	19
2.3.3.4	Results .....	19
2.3.4	Radiated Receiver Sensitivity Degradation, Simultaneous Operation (Wi-Fi Desense) .....	19
2.3.4.1	Equipment .....	19
2.3.4.2	Unicast Test Packets .....	20
2.3.4.3	Procedure .....	20
2.3.5	Radiated Cellular Receiver Sensitivity Degradation, Simultaneous Operation (Cellular Desense) .....	20
2.3.5.1	Equipment .....	20

---

2.3.5.2	Wi-Fi DUT Transmitter Stimulus.....	21
2.3.5.3	Procedure .....	22
3.	WLAN Access Point Testing Methodology .....	23
3.1	Conducted RF Tests.....	23
3.1.1	Test Set-up.....	23
3.1.2	Equipment .....	23
3.1.3	Transmit Power Measurement.....	23
3.1.3.1	Unicast Test Packets .....	23
3.1.3.2	Test Procedure .....	23
3.1.3.3	Results.....	24
3.1.4	Receive Sensitivity Measurement.....	24
3.1.4.1	Unicast Test Packets .....	24
3.1.4.2	Test Procedure .....	24
3.1.4.3	Results.....	25
3.2	Radiated RF Tests.....	25
3.2.1	Test Set-up.....	25
3.2.2	Equipment .....	26
3.2.3	Radiated Power .....	26
3.2.3.1	Discussion .....	26
3.2.3.2	Unicast Test Packets .....	26
3.2.3.3	Test Procedure .....	26
3.2.3.4	Results.....	27
3.2.4	Receive Sensitivity Measurement.....	27
3.2.4.1	Discussion .....	27
3.2.4.2	Unicast Test Packets .....	27
3.2.4.3	Test Procedure .....	27
3.2.4.4	Results.....	28
4.	Radiated Measurements .....	29
4.1	Test Conditions for Device Under Test .....	29
5.	Mobile Station Testing.....	30
5.1	Transmitter Performance .....	30
5.1.1	Conducted Power Output .....	30
5.1.1.1	DUT Requirements .....	30
5.1.1.2	Frequency Channels.....	30
5.1.1.3	Data Rates.....	30
5.1.1.4	Not Used.....	30
5.1.1.5	Results.....	30
5.1.2	Total Radiated Power (TRP).....	30
5.1.2.1	DUT Requirements .....	30
5.1.2.2	Frequency Channels.....	30
5.1.2.3	Data Rates.....	31
5.1.2.4	Results.....	31
5.2	Receiver Performance .....	31
5.2.1	Conducted Receiver Sensitivity .....	31
5.2.1.1	DUT Requirements .....	31
5.2.1.2	Frequency Channels.....	32
5.2.1.3	Data Rates.....	32
5.2.1.4	Results.....	32
5.2.2	Total Isotropic Sensitivity (TIS) .....	32
5.2.2.1	DUT Requirements .....	32

---

5.2.2.2	Frequency Channels .....	32
5.2.2.3	Data Rates .....	32
5.2.2.4	Results .....	33
5.2.3	Radiated Receiver Sensitivity, Simultaneous Operation (Wi-Fi Desense) .....	33
5.2.3.1	DUT Requirements .....	33
5.2.3.2	Positions .....	33
5.2.3.3	Highest Cellular Frequency Channel Test .....	33
5.2.3.4	Harmonic Interference Tests .....	33
5.2.3.5	Results .....	34
5.2.4	Radiated Cellular Receiver Sensitivity, Simultaneous Operation (Cellular Desense) ....	34
5.2.4.1	DUT Requirements .....	34
5.2.4.2	DUT Polarization .....	34
5.2.4.3	Wi-Fi Frequency .....	35
5.2.4.4	Cellular Technology and Frequency Band .....	35
5.2.4.5	Results .....	36
6.	Access Point Testing .....	37
6.1	Transmitter Performance .....	37
6.1.1	Conducted Power Output .....	37
6.1.1.1	APUT Requirements .....	37
6.1.1.2	Frequency Channels .....	37
6.1.1.3	Data Rates .....	37
6.1.1.4	Not Used .....	37
6.1.1.5	Results .....	37
6.1.2	Total Radiated Power (TRP) .....	37
6.1.2.1	APUT Requirements .....	37
6.1.2.2	Frequency Channels .....	37
6.1.2.3	Data Rates .....	38
6.1.2.4	Results .....	38
6.2	Receiver Performance .....	38
6.2.1	Conducted Receive Sensitivity .....	38
6.2.1.1	APUT Requirements .....	38
6.2.1.2	Frequency Channels .....	38
6.2.1.3	Data Rates .....	39
6.2.1.4	Results .....	39
6.2.2	Total Isotropic Sensitivity (TIS) .....	39
6.2.2.1	APUT Requirements .....	39
6.2.2.2	Frequency Channels .....	39
6.2.2.3	Data Rates .....	39
6.2.2.4	Results .....	40
7.	WLAN Test Set .....	41
7.1	Estimated Signal Levels .....	41
7.2	Test AP and WLAN Station Requirements .....	44
7.2.1	Basic Parameters .....	44
7.2.2	RF Parameters .....	44
7.3	WLAN Receiver RF Requirements .....	45
7.4	Attenuator Requirements .....	46
8.	Appendix A – Harmonic Interference Selection Matrices .....	48
9.	Appendix B – Summary Test Report .....	50
10.	Appendix C – RF Power Measurement .....	61
11.	APPENDIX D – IEEE 802.11a Supported Channel Option Examples .....	62

12. Appendix E – Device Testing Configurations .....63

**List of Figures**

Figure 2.1 – Block Schematic Diagram – WLAN Test Set..... 13  
 Figure 2.2 – Block Schematic Diagram – Conducted RF Tests..... 14  
 Figure 2.3 – Block Schematic Diagram – Radiated RF Tests..... 17  
 Figure 2.4 – Test Configuration – Cellular Desense due to Wi-Fi..... 21  
 Figure 3.1 – Block Schematic Diagram – Conducted RF Test for AP..... 23  
 Figure 3.2 – Block Schematic Diagram – Radiated RF Tests for AP ..... 25

**List of Tables**

Table 1.1 - Minimum Measurement Distance..... 11  
 Table 5.1 – Wi-Fi Channel and Data Rate for TIS Wi-Fi Desense ..... 33  
 Table 5.2 – Channel setting for Wi-Fi U-NII Band for TIS Cellular Desense ..... 35  
 Table 7.1 – Conducted TX Test ..... 41  
 Table 7.2 – Conducted RX Test..... 42  
 Table 7.3 – Radiated TX Test ..... 43  
 Table A.1 – IEEE 802.11b/g Products<sup>a</sup> ..... 48  
 Table A.2 – IEEE 802.11a Products..... 49  
 Table B.1 – Sample Summation ..... 50  
 Table B.2 – Conducted Power Output Results..... 50  
 Table B.3 – Mode Radiated Figure of Merit Results..... 51  
 Table B.4 – Radiated Reference Measurements Results..... 51  
 Table B.5 – Conducted Receiver Sensitivity Results..... 53  
 Table B.6 – Mode Sensitivity Figure of Merit Results ..... 54  
 Table B.7 – Sensitivity Reference Measurements Results ..... 55  
 Table B.8 – Highest Cellular Frequency Channel Test Results ..... 57  
 Table B.9 – Harmonic Interference Tests Results 802.11b&g ..... 58  
 Table B.10 – Harmonic Interference Tests Results 802.11a ..... 58  
 Table B.11 – Cellular Desense Test Results for 802.11b&g Operation ..... 59  
 Table B.12 – Cellular Desense Test Results for 802.11a Operation..... 60

---

## List of Acronyms and Definitions

ACK	Acknowledge
AMPS	Advanced Mobile Phone System
APSD	Automatic Power Save Delivery
APUT	Access Point Under Test
BPSK	Binary Phase Shift Keying
CCK	Complementary Code Keying
CDMA	Code Division Multiple Access
DBPSK	Differential Binary Phase Shift Keying
DQPSK	Differential Quadrature Phase Shift Keying
DSSS	Direct Sequence Spread Spectrum
DUT	Device Under Test
EUT	Equipment Under Test
FRR	Frame Reception Rate
GSM	Global System for Mobile communication
iDEN	Integrated Digital Enhanced Network
LAN	Local Area Network
LCR	Low Chip Rate
OFDM	Orthogonal Frequency Division Multiplexing
PER	Packet Error Rate
PHS	Personal Handyphone System (Japan)
QAM	Quadrature Amplitude Modulation
QPSK	Quadrature Phase Shift Keying
RSSI	Receive Signal Strength Indicator
Rx	Receive Signal Strength Indicator
SSID	Service Set Identifier
STA	Station
TIS	Total Isotropic Sensitivity
TRP	Total Radiated Power
Tx	Transmit
UMTS	Universal Mobile Telecommunications System
UTRA-FDD	UMTS Terrestrial Radio Access - Frequency Division Duplexing
UTRA-TDD	UMTS Terrestrial Radio Access - Time Division Duplexing
WLAN	Wireless Local Area Network



---

## 1. INTRODUCTION

### 1.1 Background

Increasingly the wireless market is seeing converged handset devices that incorporate both cellular and wireless local area network (WLAN or Wi-Fi) functionality. Cellular operators are becoming one of the largest classes of Wi-Fi service providers<sup>1</sup> and are increasingly working to integrate more WLAN support into their overall operations. Due to the many potential applications and deployment scenarios that converged equipment may ultimately function in, operators and handset vendors are interested in a uniform method of profiling the RF performance of converged devices. With this profile data gathered in a uniform way, equipment designers, system operators, and RF engineers have the flexibility to determine their own appropriate RF performance criteria based on their engineering assessments, and they can easily identify equipment that is suitable for each deployment and application.

### 1.2 Scope

This Test Document contains the proposed test methodologies and performance criteria for the RF performance evaluation of Wi-Fi mobile converged devices. The scope of testing includes devices that support IEEE 802.11a, IEEE 802.11b or 802.11g, as well as one or more cellular technologies. Support for IEEE standards must be confirmed through Wi-Fi Alliance baseline certification—that is, devices tested using this testplan must first be Wi-Fi CERTIFIED for IEEE 802.11a, 802.11b, or 802.11g<sup>2</sup>. Cellular technologies include, but are not limited to, GSM, CDMA, UMTS, operating at conventional 450, 800, 900, 1800, 1900 and 2100 MHz frequencies.

### 1.3 Purpose

The purpose of this document is first to define the test methodology for the RF Testing of Wi-Fi mobile converged devices and then to specify the test conditions for each proposed test. The testing covers client devices and access points, and specifies conducted as well as radiated tests.

The test methodology requires the device be placed in a standard operational mode. Although recognizing that the use of special test modes would enable more simplified testing and the use of formal test equipment, the test methodology proposed in this document allows the testing of any Wi-Fi mobile device in a mode that is as close as possible to its native operation.

This test plan is part of the CTIA and Wi-Fi Alliance certification programs. The CTIA Certification Program is explained in a separate document titled CTIA Certification Program Management Document [4]. The Wi-Fi Alliance Certification Program is explained in a separate document titled Wi-Fi Alliance Program Management Document [5].

### 1.4 References

(1) - “Test Plan for Mobile Station Over the Air Performance/Method of Measurement for Radiated RF Power and Receiver Performance”, latest revision, CTIA

---

<sup>1</sup> Planet Wireless, September, 2004 “PW Hotspot Operator Database: Public-WLAN coverage by operator, country, and region”

<sup>2</sup> Check the product’s Wi-Fi Certificate at [http://certifications.www.wi-fi.org/wbcs\\_certified\\_products.php?lang=en](http://certifications.www.wi-fi.org/wbcs_certified_products.php?lang=en) use Advance Search option and enter CID. If CWG certification already exists then a new CID is required.

---

(2) - IEEE Std. 802.11b – 1999 (Supplement to ANSI/IEEE Std 802.11, 1999 Edition)  
IEEE Std 802.11a – 1999 “Amendment 1: High-speed Physical Layer in the 5GHz band”

(3) - IEEE P802.11g/D8.2, Apr 2003 (Supplement to ANSI/IEEE Std 802.11 1999(Reaff 2003)), “Further Higher Rate Extension in the 2.4GHz Band”

(4) - CTIA Certification Program Management Document, Latest Revision, CTIA.

(5) - Wi-Fi Alliance Program Management Document, Latest Revision, Wi-Fi Alliance.

## **1.5 Test Nomenclature Overview**

### **1.5.1 Radiated RF Tests**

Radiated tests are those RF Tests that are carried out in a test environment which meets the requirements of the CTIA Test Plan [1], Section 3. These include TX Power (TRP) in WLAN mode, Receive Sensitivity (TIS) in WLAN mode, Receive Sensitivity of WLAN with cellular active (in a call), and Receive Sensitivity of the cellular radio(s) with WLAN active<sup>3</sup>.

### **1.5.2 Conducted RF Tests**

Conducted tests are those RF Tests where the test equipment is connected to the antenna connector of the device under test by co-axial cables. These tests are formulated to measure basic RF performance such as sensitivity and transmit power. These tests may require the use of screened compartments.

## **1.6 Characterization of Measurements**

### **1.6.1 Measurement Techniques**

This document relies on the measurement techniques within a CTIA Test Plan developed specifically for the purposes of measurement of radiated transmit power and sensitivity. These techniques are described in detail in Section 2, Scope of Measurements, of the CTIA Test Plan for Mobile Station Over the Air Performance [1]. That section describes fully the nature of the measurement technique used in this document.

The following sub-sections of this document contain information to expand the CTIA Test Plan [1] for use with 802.11 a, b and g devices. These sections are meant to clarify for the user how the CTIA Test Plan [1] can be utilized for Wi-Fi devices.

### **1.6.2 Measurement Uncertainty**

A complete and thorough expanded uncertainty budget is required of those facilities performing tests for the purposes of certification of devices against this test plan. Laboratories shall use Section 7 and Appendix G of the CTIA Test Plan [1] as guidance for the determination of measurement uncertainty. The laboratory is also responsible for identifying any other contributing factors to their uncertainty

---

<sup>3</sup> TRP and TIS in cellular mode are defined in the CTIA Test Plan for Mobile Station Over the Air Performance [1]

budget. In addition to the maintenance of such an uncertainty budget, the total measurement uncertainty is to be reported in the final evaluation report.

**1.6.3 Minimum Measurement Distance**

This section describes the minimum measurement distance based on a 300 mm test volume, R, which the far-field test site shall provide. The measurement distance is defined as the distance from the center of rotation of the EUT to the phase center of the measurement antenna. The minimum measurement distance is specified in Table 1.1, below.

Table 1.1 - Minimum Measurement Distance

Frequency Band	Minimum Measurement Distance R, meters
ISM (2400 – 2497 MHz)	TBD
U-NIII (5000 – 6000 MHz)	TBD

The minimum acceptable measurement distance is the larger of 3D (the amplitude uncertainty limit) and  $3\lambda$  (the reactive Near-Field limit), where D is the dimension of the radiator and  $\lambda$  is the free-space wavelength at the measurement frequency. It is recommended, however, that the measurement distance be greater than the largest of  $2D^2/\lambda$  (the phase uncertainty limit), 3D, and  $3\lambda$ . For a free space test, D would simply be the largest dimension of the EUT, but some portion of the phantom must be included for phantom (simulated use) tests. For purposes of this test plan, D is selected to be the dimension of that part of the phantom that participates significantly in determining the TRP or TIS of the EUT, and is chosen as 300 mm. The requirement of  $2D^2/\lambda$  is suggested rather than required. When using a range distance down to the higher of either 3D or  $3\lambda$ , the impact to TRP and TIS must be included in the calculation of the overall Measurement Uncertainty.

**1.6.4 Equipment Required**

Additional equipment needed:

1. ISM-band sleeve dipole probe antenna with less than  $\pm 0.1$  dB of asymmetry in the azimuth plane pattern.
2. ISM-band reference loop probe antenna with less than  $\pm 0.1$  dB of asymmetry in the azimuth plane pattern
3. U-NII-band sleeve dipole probe antenna with less than  $\pm 0.1$  dB of asymmetry in the azimuth plane pattern.
4. U-NII-band reference loop probe antenna with less than  $\pm 0.1$  dB of asymmetry in the azimuth plane pattern (this requirement waived until a U-NIII-band loop probe antenna is available).

**1.6.5 Quiet Zone Test Frequencies**

Quiet zone test frequencies needed for Wi-Fi bands:

1. ISM-band: 2450 MHz  $\pm$  1MHz
2. U-NIII-band: 5500 MHz  $\pm$  1MHz

---

## 2. WLAN CLIENT TESTING METHODOLOGY

The test methodology proposed in this document allows the testing of any WI-FI mobile converged device in a mode that is as close as possible to its native operation. However, the methodology finally arrived at does require certain specific behavior of a client so that the test can be completed. The WLAN client is expected to be able to associate with an AP and stay fixed on the same RF channel for the duration of the test, even when the signal from the AP is below the sensitivity level for the PHY rate being tested. The Test AP will be transmitting data frames addressed to the WLAN client at about 50 frames per second, and the WLAN client is expected to be able to respond to all of these data frames with an ACK. The duration of radiated tests may run until the battery is expended.

The above requirements require the following client settings:

1. Disable scan mode during testing. Scanning for APs on other channels must be disabled
2. If applicable, disable Power Save Mode (Note that the Test AP will not support WMM APSD)
3. The client should actively attempt to re-associate with the AP after losing association due to the signal decreasing below the client's sensitivity level.
4. If applicable, disable BlueTooth radio during tests
5. For non-coexistence tests, the cellular transmitter in the client should be inactive. For devices which cannot disable their cellular radio, this may be accomplished by testing within an appropriate shielded environment to isolate the DUT from any base station signals.

There may be other settings required to achieve the goals described above.

It should be noted that although the transmit and receive tests are described separately, the test procedures are such that it should be possible to conduct both the transmit power and receive sensitivity measurements at the same time.

## 2.1 WLAN Test Set

The RF tests described in this document are based upon a “WLAN Test Set”, which is shown diagrammatically in Figure 2.1.

Figure 2.1 – Block Schematic Diagram – WLAN Test Set

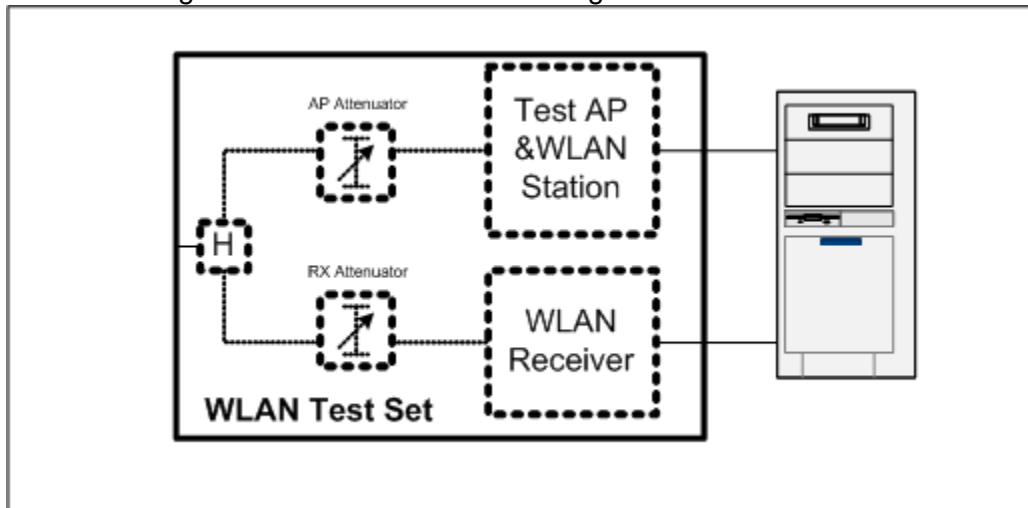

The WLAN Test Set comprises the following:

- Test Access Point and WLAN Station

When testing Client devices, this module’s functions are similar to a WLAN Access Point, but with superior transmitter performance. It is connected to a Control PC and is used to generate unicast packets on any selected channel and at any selected fixed data rate, i.e. with retransmission and rate fallback functionality disabled. When testing Access Points, this module’s function are similar to a WLAN Station, but with superior transmitter performance.

The RF Specifications are given in Section 7.2.

- WLAN Receiver

Functionally this module is similar to a WLAN Sniffer but has a superior receive RSSI performance. The RF Specifications are given in Section 7.3. It is connected to a Control PC and is used to report the RSSI of received packets and to record the number of ACK control packets per second.

- Hybrid Combiner

A hybrid combiner is suggested, although other methods of connecting RF signals are also acceptable, such as a resistive splitter or a circulator.

- AP Attenuator

This attenuator is used to adjust the transmit output power from the Test AP, presented to the hybrid combiner.

- RX Attenuator

This attenuator is used to adjust the level of the received signal from the hybrid combiner to the input of the WLAN Receiver.

The transmit output power of the Test Access Point and the RSSI reporting of the WLAN Receiver are subject to a validation procedure, which is performed immediately after each transmit and receiver sensitivity set of measurements, hence formal calibration of the WLAN Test Set is not required.

## 2.2 Conducted RF Tests

### 2.2.1 Test Set-up

The basic test set-up is shown in Figure 2.2.

Figure 2.2 – Block Schematic Diagram – Conducted RF Tests

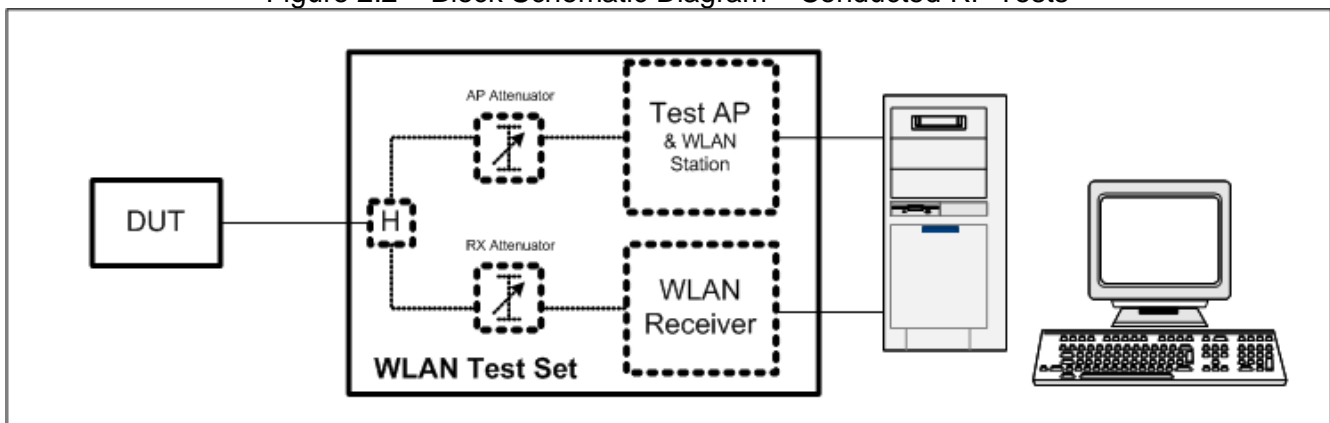

### 2.2.2 Transmit Power Measurement

#### 2.2.2.1 Discussion

The method used is based upon the validated RSSI, from the WLAN Receiver module in the WLAN Test Set, reporting the received signal strength of an ACK control frame from the DUT. The ACK control frames are sent in response to unicast data packets generated by the Test Access Point module in the WLAN Test Set.

The RSSI is measured across the header of the control packet with a time period that is not more than one period of a short preamble. The measurement is to be taken across several packets and a mean value calculated.

The ACK control frame is sent at the basic data rate at or below the data rate of the received signal. This effectively means that the transmitted data rate from the DUT will be 6, 12 or 24Mbps for OFDM rates, and 1, 2, and 5.5, 11 for DSSS-CCK rates. The vendor shall provide the list of data rates for the ACK control frames so that the Access Point data rate can be set correctly.

#### 2.2.2.2 Unicast Test Packets

The unicast test data packets shall be 200 frame bytes at a rate of 50 frames a second, to approximate a voice data stream.

---

### 2.2.2.3 Test Procedure

The recommended procedure is:

1. The AP attenuator, in the WLAN Test Set, is set such that the signal received at the DUT antenna connector is at least 10dB higher than the sensitivity threshold.
2. The RX Attenuator, in the WLAN Test Set is set such that the received signal level from the DUT at the input of the WLAN Receiver is at least 10dB higher but not more than 50dB higher than the sensitivity threshold.
3. The Test AP, in the WLAN Test Set, is set to transmit on the desired channel and at the desired modulation and data rate.
4. The Device Under Test (DUT) associates with the Test AP.
5. The Test AP is set to continuously transmit unicast test data packets to the DUT.
6. The DUT will respond to the received unicast data packets with an ACK control frame.
7. The WLAN Receiver reports the reception of the ACK control frame together with the data rate and the RSSI reading to the Control PC. Calculate and record the mean value of RSSI over a period of about 10 seconds.
8. Repeat steps 3 to 7 for each required channel and data rate.
9. Create a Table of Channel, Modulation, Data Rate and Mean RSSI for each measurement. See Appendix B for recommended data reporting formats.

Convert RSSI Readings:

10. Remove the DUT and connect in its place a Vector Signal Generator capable of generating WLAN IEEE 802.11a/b/g frames.
11. Set the Signal Generator to send a WLAN ACK control frame, on the desired center frequency, with the correct modulation and data rate as per the first measurement in the Table created in step 9.
12. Set the WLAN Receiver to the same channel as the Signal Generator.
13. Monitor the RSSI reported by the WLAN Receiver.
14. Adjust the Signal Generator output level such that the RSSI reported by the WLAN Receiver is that recorded in the corresponding Receive Sensitivity measurement in the Table created in step 9, and record the Output Level of the Signal Generator, to the nearest dBm, in an extra column of the Table.

Note: To reduce the required output level of the Signal Generator, the RX Attenuator may be decreased in value and the difference accounted for in the tabulated results.

15. Repeat steps 11 - 14 for all the data rates and channels in the Table created in Step 9.

### 2.2.2.4 Results

The Results shall be in the form of a Table of Channel, Modulation, Data Rate, Mean RSSI, and Transmit Power dBm. See Appendix B for recommended data reporting formats.

## 2.2.3 Receive Sensitivity Measurement

### 2.2.3.1 Discussion

The method used is based upon the WLAN Receive, in the WLAN Test Set, reporting the number of ACK control frames per second being sent by the DUT in response to continuous unicast data packets

---

being sent from the Test AP. For this test the output transmitted power from the Test AP needs to be validated.

### 2.2.3.2 Unicast Test Packets

The unicast test data packets shall be 200 frame bytes at a rate of 50 frames a second, to approximate a voice data stream.

### 2.2.3.3 Test Procedure

The recommended procedure is:

1. The AP Attenuator, in the WLAN Test Set, is set such that the signal received at the DUT antenna connector is about 10dB higher than the sensitivity threshold.
2. The RX Attenuator, in the WLAN Test Set is set such that the received signal level from the DUT at the input of the WLAN Receiver is at least 10dB higher but not more than 50dB higher than the sensitivity threshold.
3. The Test AP is set up to transmit on the desired channel, modulation and data rate.
4. The Device Under Test (DUT) associates with the AP.
5. The Test AP is set to continuously transmit unicast data packets to the DUT.
6. The DUT will respond to the received unicast data packets with an ACK control frame.
7. The WLAN Receiver reports the reception of the ACK control frames to the Control PC.
8. The Control PC counts the number of data frames and the number of ACK control frames received over a time period needed to receive 100 (TBR) data frames and the corresponding ACKs. The frame reception rate (FRR) is computed as (# of ACKs received / # data frames transmitted)
9. The AP attenuator is increased, until the FRR reduces to the point where a 1dB increase causes the FRR to be less than 90%.
10. The AP Attenuator is decreased by 1dB and the value noted, "A" dB
11. Repeat steps 3 to 10 for each required channel, modulation and data rate.
12. Create a Table of Channel, Modulation, Data Rate, and AP Attenuator Setting. See Appendix B for recommended data reporting formats.

Convert the Test AP and AP Attenuator setting:

13. Measure the power level to an accuracy of 0.5dBm, "P"dBm as per the method described in Appendix C.
14. From the power level measured in step 13, add 10dB and deduct the value of the AP Attenuator noted in step 10, i.e.  $P + 10 - A$ . Record this value, the Receive Sensitivity, to an accuracy of 1dBm, in an extra column to the Table created in step 12.
15. Repeat steps 13 - 14 for all the channels, modulations, and data rates and used in the measurement taking.

### 2.2.3.4 Results

The results shall be in the form of a Table of Channel, Modulation, Data Rate, AP Attenuator setting and Receive Sensitivity (10%PER). See Appendix B for recommended data reporting formats.



## 2.3 Radiated RF Tests

It should be noted that as the transmitted power and the receive sensitivity measurements both use the ACK control packet generated by the DUT and received by the WLAN Receiver, it is possible to carry out both tests, one after the other, at each position of the test antennas used in the radiated RF measurements.

### 2.3.1 Test Set-up

The basic test set-up is similar to that for the radiated tests and is shown in Figure 2.3.

Figure 2.3 – Block Schematic Diagram – Radiated RF Tests

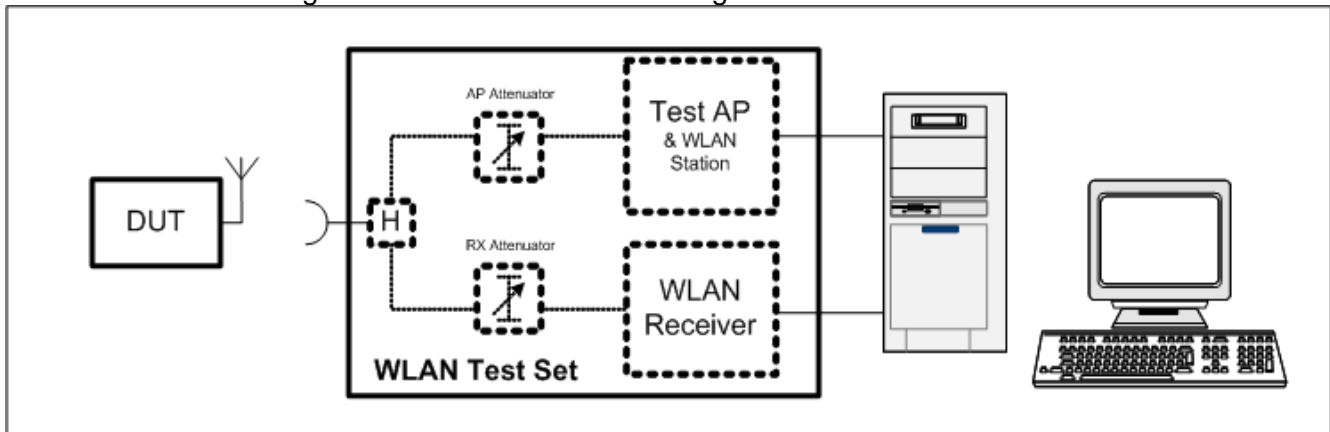

### 2.3.2 Radiated Power

#### 2.3.2.1 Discussion

The method used is similar to the conducted transmit measurement with the exception that the co-axial connection between the hybrid splitter and the DUT is now made using the DUT antenna(s) and a calibrated test antenna. The radiated path loss, from the position of the DUT antenna(s), including the test antenna, shall be calibrated.

The procedure described below relates to each individual measurement and will need to be repeated for each position and data rate specified for the device under test.

#### 2.3.2.2 Unicast Test Packets

The unicast test data packets shall be 200 frame bytes at a rate of 50 frames a second, to approximate a voice data stream.

#### 2.3.2.3 Test Procedure

The procedure is identical to that of the conducted transmit power measurement. The settings for the Test AP and RX attenuators will be different due to extra loss of the radiated path. It is assumed that path loss and gain of the Test Antenna are known.

The recommended procedure is:

1. The AP attenuator, in the WLAN Test Set, is set such that the signal received at the DUT antenna connector is at least 10dB higher than the sensitivity threshold.
2. The RX Attenuator, in the WLAN Test Set is set such that the received signal level from the DUT at the input of the WLAN Receiver is at least 10dB higher than the sensitivity threshold.
3. The Test AP, in the WLAN Test Set, is set up to transmit on the desired channel and at the desired modulation and data rate.
4. The Device Under Test (DUT) associates with the Test AP.
5. The Test AP is set to continuously transmit unicast data packets to the DUT.
6. The DUT will respond to the received unicast data packets with an ACK control frame.
7. The WLAN Receiver reports the reception of the ACK control frame together with the data rate and the RSSI reading to the Control PC. Note the mean value of RSSI over a period of about 10 seconds.
8. Repeat steps 3 to 7 for each required channel and data rate.
9. Create a Table of Channel, Modulation, Data Rate and Mean RSSI for each measurement. See Appendix B for recommended data reporting formats.

#### Convert RSSI Readings:

10. Remove the Test Antenna and connect in its place a Vector Signal Generator capable of generating WLAN IEEE 802.11a/b/g frames.
11. Increase the RX Attenuator setting by an amount equal to the path loss minus the gain of the Test Antenna.
12. Set the Signal Generator to send a WLAN ACK control frame, on the desired center frequency, with the correct modulation and data rate as per the first measurement in the Table created in step 9.
13. Set the WLAN Receiver to the same channel as the Signal Generator.
14. Monitor the RSSI reported by the WLAN Receiver.
15. Adjust the Signal Generator output level such that the RSSI reported by the WLAN Receiver is that recorded in the corresponding Receive Sensitivity measurement in the Table created in step 9, and record the Output Level of the Signal Generator, to the nearest dBm, in an extra column of the Table.  
Note: To reduce the required output level of the Signal Generator, the RX Attenuator may be decreased in value and the difference accounted for in the tabulated results.
16. Repeat steps 12 - 15 for all the data rates and channels in the Table created in Step 9.

#### 2.3.2.4 Results

The Results shall be in the form of a Table of Channel, Modulation, Data Rate, Mean RSSI, and Transmit Power dBm. See Appendix B for recommended data reporting formats.

### 2.3.3 Receive Sensitivity Measurement

#### 2.3.3.1 Discussion

The method used is similar to the conducted measurement with the exception that the co-axial connection between the hybrid splitter and the DUT is now made using the DUT antenna(s) and a calibrated test antenna. The radiated path loss from the position of the DUT antenna(s), including the test antenna, shall be validated.

### 2.3.3.2 Unicast Test Packets

The unicast test data packets shall be 200 frame bytes at a rate of 50 frames a second, to approximate a voice data stream.

### 2.3.3.3 Procedure

The recommended procedure is:

1. The AP Attenuator, in the WLAN Test Set, is set such that the signal received at the DUT antenna connector is about 10dB higher than the sensitivity threshold.
2. The RX Attenuator, in the WLAN Test Set is set such that the received signal level from the DUT at the input of the WLAN Receiver is at least 10dB higher but not more than 50dB higher than the sensitivity threshold.
3. The Test AP is set up to transmit on the desired channel, modulation and data rate.
4. The Device Under Test (DUT) associates with the AP.
5. The Test AP is set to continuously transmit unicast data packets to the DUT.
6. The DUT will respond to the received unicast data packets with an ACK control frame.
7. The WLAN Receiver reports the reception of the ACK control frames to the Control PC.
8. The Control PC counts the number of data frames and the number of ACK control frames received over a time period needed to receive 100 (TBR) data frames and the corresponding ACKs. The frame reception rate (FRR) is computed as (# of ACKs received / # data frames transmitted)
9. The AP attenuator is increased, until the FRR reduces to the point where a 1dB increase causes the FRR to be less than 90%.
10. The AP Attenuator is decreased by 1dB and the value noted, "A" dB
11. Repeat steps 1 to 10 for each required channel, modulation and data rate.
12. Create a Table of Channel, Modulation, Data Rate, and AP Attenuator Setting. See Appendix B for recommended data reporting formats.

Convert the Test AP and AP Attenuator setting:

13. Measure the power level to an accuracy of 0.5dBm, "P"dBm as per the method described in Appendix C.
14. From the power level measured in step 13, add 10dB and deduct the value of the AP Attenuator noted in step 10, i.e.  $P + 10 - A$ . Record this value, the Receive Sensitivity, to an accuracy of 1dBm, in an extra column to the Table created in step 12.
15. Repeat steps 13 - 14 for all the channels, modulations, and data rates and used in the measurement taking.

### 2.3.3.4 Results

The results shall be in the form of a Table of Channel, Modulation, Data Rate, AP Attenuator setting and Receive Sensitivity. See Appendix B for recommended data reporting formats.

## **2.3.4 Radiated Receiver Sensitivity Degradation, Simultaneous Operation (Wi-Fi Dense)**

### 2.3.4.1 Equipment

The test set-up is as per 2.3.1, but with the addition of a Cellphone base station emulator. The Cellphone emulator antenna is placed in a suitable position within the anechoic chamber. The test

shall be carried out at only one position of the test antenna that corresponds to the maximum radiation of the DUT as determined in the TRP and TIS measurements. Wi-Fi desense shall be measured free-space only.

#### 2.3.4.2 Unicast Test Packets

The unicast test data packets shall be 200 frame bytes at a rate of 50 frames a second, to approximate a voice data stream.

#### 2.3.4.3 Procedure

The recommended procedure is:

1. The AP Attenuator, in the WLAN Test Set, is set such that the signal received at the DUT antenna connector is about 10dB higher than the sensitivity threshold.
2. The RX Attenuator, in the WLAN Test Set is set such that the received signal level from the DUT at the input of the WLAN Receiver is at least 10dB higher but not more than 50dB higher than the sensitivity threshold.
3. The Test AP is set up to transmit on the desired channel, modulation and data rate.
4. The Device Under Test (DUT) associates with the AP.
5. The Test AP is set to continuously transmit unicast data packets to the DUT.
6. The DUT will respond to the received unicast data packets with an ACK control frame.
7. The WLAN Receiver reports the reception of the ACK control frames to the Control PC and the number of ACK frames per second is noted.
8. The Control PC counts the number of data frames and the number of ACK control frames received over a time period needed to receive 100 (TBR) data frames and the corresponding ACKs. The frame reception rate (FRR) is computed as (# of ACKs received / # data frames transmitted)
9. The AP attenuator is increased, until the FRR reduces to the point where a 1dB increase causes the FRR to be less than 90%.
10. The AP Attenuator is decreased by 1dB and the value noted, "A"dB
11. The cellphone of the converged device is then activated, and using the Cellular Base Station, the device is made to simulate being in a standard voice call. The cellular phone shall be made to transmit at the highest power.
12. The AP Attenuator is then decreased, until the FRR is at the point where a 1dB increase causes the FRR to be less than 90%.
13. The AP Attenuator is decreased by 1dB and the value noted, "B"dB.
14. The Receive Sensitivity degradation is then calculated by subtracting the reading noted in step 10 from the reading noted in step 13, i.e. Receive sensitivity degradation is "B-A" dB. Note the Receive Degradation value.
15. Repeat steps 3 to 14 for each required channel, modulation and data rate.
16. Create a Table of Channel, Modulation, Data Rate and Receive Degradation.

### **2.3.5 Radiated Cellular Receiver Sensitivity Degradation, Simultaneous Operation (Cellular Desense)**

#### 2.3.5.1 Equipment

The test set up is shown in figure 2.4, where the Converged Device and the Access Point antenna are placed in a suitable position within an anechoic chamber. The test shall be carried out at only one position of the test antenna that corresponds to the maximum receive sensitivity (Reference

Polarization and Orientation Position) as determined in the TIS, free space, full channel, cellular DUT measurement. If the DUT's cellular radio has not been tested previously, then a reference TIS measurement must also be made in the free-space configuration to determine the reference value and position.

Figure 2.4 – Test Configuration – Cellular Desense due to Wi-Fi

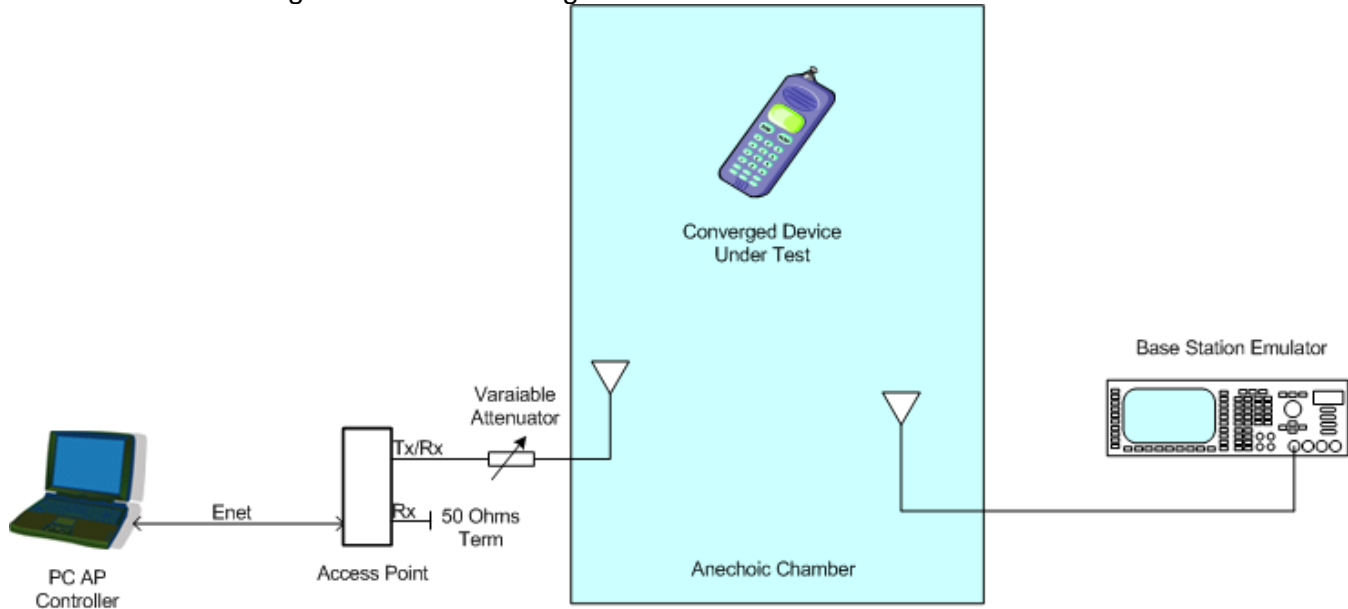

### 2.3.5.2 Wi-Fi DUT Transmitter Stimulus

Continuous short unicast UDP packets are transmitted by the Access Point using the MAC address of the Wi-Fi DUT. The DUT will respond with continuous ACKs which will be transmitted at maximum power. A traffic generator runs on the PC AP Controller, and generates continuous unicast packets. The traffic generator software is available from the Wi-Fi Alliance web site as an executable. The AP Tx/Rx analog output is connected to the antenna, inside the chamber, using a variable attenuator<sup>4</sup>. The purpose of the attenuator is to make sure that the transmit signal from the AP does not impact the relative sensitivity measurement in the DUT. If the DUT is an 802.11b device the ACKs will be transmitted at 1 Mbps (long preamble<sup>5</sup>). With the AP data rate set to “auto” the AP transmitted data will be 11 Mbps. This setup will achieve a repetition time of approximately 630  $\mu$ s<sup>6</sup>. If the DUT is an 802.11g or an 802.11a device the ACKs will be transmitted at 6 Mbps. With the AP data rate set to “auto” the transmitted data from the AP will be 54 Mbps. This setup will achieve a repetition time of approximately 165  $\mu$ s.

<sup>4</sup> Sufficient attenuation to stop the AP Tx compromising relative sensitivity measurements, but allows DUT to run at desired data rate (maximum attenuation 30 dB).

<sup>5</sup> Using short preamble the repetition rate will be approximately 400  $\mu$ s.

<sup>6</sup> Using short preamble the repetition time will be approximately 400  $\mu$ s.

---

### 2.3.5.3 Procedure

TIS testing needs to be performed for the antenna in retracted and extended position if applicable. Follow the set up and test procedure described in section 6 of the CTIA “Test Plan for Mobile Station Over-The Air Performance” version 2.1, for the modulation to be tested.

1. Make the Cellular receiver sensitivity measurement, on three channels (low, middle, high), with the Wi-Fi radio off. Record the values.
2. Turn on the Wi-Fi radio and let the Wi-Fi DUT associate with the AP using appropriate settings of the DUT and AP<sup>7</sup>. Use transmitter stimulus described in section 2.3.5.2 of this document.
3. Start the traffic generator on the PC AP Controller to stimulate the Wi-Fi DUT transmitter.
4. The traffic generator will initially carry out a ping test on the DUT. If the ping response is good then UDP packet generation commences either on a continuous or for a pre-defined number basis. At the end of the packet generation a final ping test is carried out.
5. Increase the cellular base station emulator transmit power by 5 dB.
6. Make the Cellular relative receiver sensitivity<sup>8</sup> measurement with the Wi-Fi radio on following the procedure described in section 6 corresponding to the modulation of the DUT.
7. Relative sensitivity measurements shall be repeated on all or any combination of intermediate channels, provided that the 500 kHz maximum separation rule is followed.
8. Record results. See Appendix B for recommended data reporting formats.

---

<sup>7</sup> AP IP Address 10.10.2.10, DUT IP Address 10.10.2.12, no security, set AP to appropriate channel #, Power save mode off in the DUT, Auto data rate, do not select mixed mode (only b or g or a), select AP to short preamble mode.

<sup>8</sup> Relative sensitivity is measured by moving the DUT positioner to the reference polarization and orientation position (best radiated receiver sensitivity). Choose the appropriate polarization and orientation settings that are closest in frequency (low, middle, high band) with frequency being measured. Using base station emulator, measure the appropriate Digital Error Rate as defined in sections 6.2 (CDMA), 6.3 (TDMA), 6.4 (GSM) of the CTIA Test Plan for Mobile Station Over the Air Performance [1], for the cellular modulation to be tested.

### 3. WLAN ACCESS POINT TESTING METHODOLOGY

The test set-up and equipment is similar to that used for the Client testing.

#### 3.1 Conducted RF Tests

##### 3.1.1 Test Set-up

The basic test set-up is shown in Figure 3.1. The Access Point under test (APUT) is controlled by the PC, through the Ethernet port. The WLAN Station is simply used to communicate with the APUT. The validation of the WLAN Station is similar to that required for the Test AP.

Figure 3.1 – Block Schematic Diagram – Conducted RF Test for AP

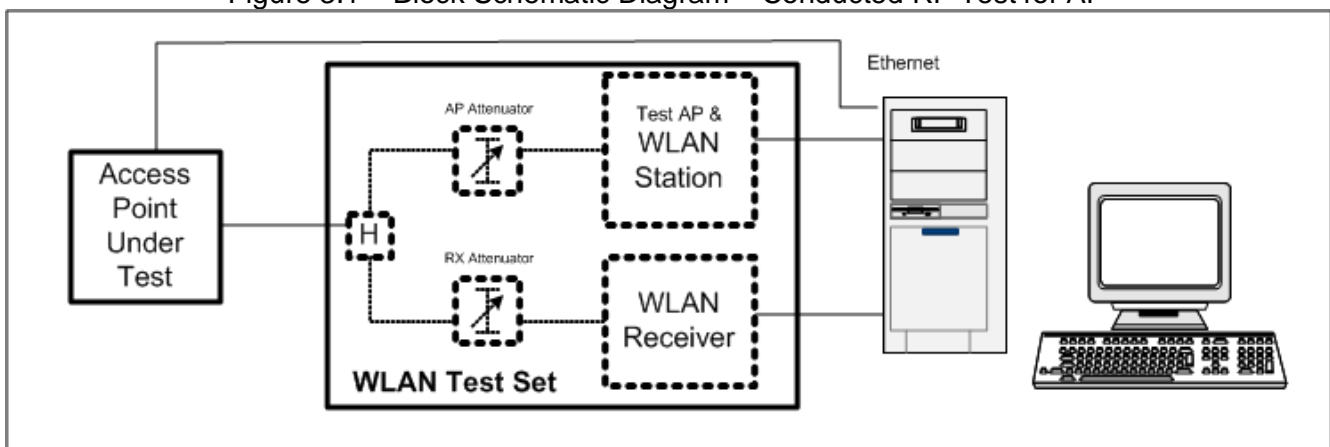

##### 3.1.2 Equipment

The APUT shall be provided with facilities that enable the Control PC to set the SSID, channel, modulation and data rate.

##### 3.1.3 Transmit Power Measurement

###### 3.1.3.1 Unicast Test Packets

The unicast test data packets shall be 200 frame bytes at a rate of 50 frames a second, to approximate a voice data stream.

###### 3.1.3.2 Test Procedure

The recommended procedure is:

1. The AP Attenuator is set such that the signal received at the WLAN APUT's antenna connector is at least 10dB higher than the sensitivity threshold.
2. The RX Attenuator, in the WLAN Test Set is set such that the received signal level from the APUT at the input of the WLAN Receiver is at least 10dB higher but not more than 50dB higher than the sensitivity threshold.
3. The AP under test (APUT) is set up to transmit on the desired channel, modulation and at the desired data rate.
4. The WLAN Station, in the WLAN Test Set, associates with the APUT.

5. The WLAN Station is set to continuously transmit unicast test data packets to the APUT, which responds with ACK control packets.
6. The WLAN Receiver reports the reception of the APUT ACK transmissions together with the data rate and the RSSI reading to the Control PC. Note the mean value of RSSI over a period of about 10 seconds.
7. Repeat steps 3 to 6 for each required channel and data rate.
8. Create a Table of Channel, Modulation, Data Rate and Mean RSSI for each measurement. See Appendix B for recommended data reporting formats.

#### Convert RSSI Readings:

9. Disconnect the cable to the APUT and connect it to the input of a Vector Signal Generator capable of generating WLAN IEEE 802.11a/b/g frames.
10. Set the Signal Generator to send a WLAN ACK control frame, on the desired center frequency, with the correct modulation and data rate as per the first measurement in the Table created in step 8.
11. Set the WLAN Receiver to the same channel as the Signal Generator.
12. Monitor the RSSI reported by the WLAN Receiver.
13. Adjust the Signal Generator output level such that the RSSI reported by the WLAN Receiver is that recorded in the corresponding Receive Sensitivity measurement in the Table created in step 8, and record the Output Level of the Signal Generator, to the nearest dBm, in an extra column of the Table.

Note: To reduce the required output level of the Signal Generator, the RX Attenuator may be decreased in value and the difference accounted for in the tabulated results.

14. Repeat steps 10 - 13 for all the channels, modulations, and data rates in the Table created in Step 8.

#### 3.1.3.3 Results

The Results shall be in the form of a Table of Channel, Modulation, Data Rate, Mean RSSI, and Transmit Power dBm. See Appendix B for recommended data reporting formats.

#### 3.1.4 Receive Sensitivity Measurement

##### 3.1.4.1 Unicast Test Packets

The unicast test data packets shall be 200 frame bytes at a rate of 50 frames a second, to approximate a voice data stream.

##### 3.1.4.2 Test Procedure

The recommended procedure is:

1. The AP Attenuator is set such that the signal received at the APUT antenna connector is about 10dB higher than the sensitivity threshold.
2. The RX Attenuator, in the WLAN Test Set is set such that the received signal level from the APUT at the input of the WLAN Receiver is at least 10dB higher but not more than 50dB higher than the sensitivity threshold.
3. The APUT is set up to transmit on the desired channel, modulation and data rate.
4. The WLAN Station, in the WLAN Test Set, associates with the APUT.



5. The WLAN Station is set to continuously transmit unicast data packets to the APUT.
6. The APUT will respond to the received unicast data packets with an ACK control frame.
7. The WLAN Receiver reports the reception of the ACK control frames to the Control PC
8. The Control PC counts the number of data frames and the number of ACK control frames received over a time period needed to receive 100 (TBR) data frames and the corresponding ACKs. The frame reception rate (FRR) is computed as (# of ACKs received / # data frames transmitted)
9. The AP attenuator is increased, until the FRR reduces to the point where a 1dB increase causes the FRR to be less than 90%.
10. The AP Attenuator is decreased by 1dB and the value noted, "A"dB
11. Repeat steps 3 to 10 for each required channel, modulation and data rate.
12. Create a Table of Channel, Modulation, Data Rate, and AP Attenuator Setting. See Appendix B for recommended data reporting formats.

Convert the Test AP and AP Attenuator setting:

Convert the Test AP and AP Attenuator setting:

13. Measure the power level to an accuracy of 0.5dBm, "P"dBm as per the method described in Appendix C.
14. From the power level measured in step 13, add 10dB and deduct the value of the AP Attenuator noted in step 9, i.e. "P + 10 – A". Record this value, the Receive Sensitivity, to an accuracy of 1dBm in an extra column to the Table created in step 11
15. Repeat steps 13 - 14 for all the channels, modulations, and data rates and used in the measurement taking.

### 3.1.4.3 Results

The results shall be in the form of a Table of Channel, Modulation, Data Rate, AP Attenuator setting and Receive Sensitivity (10%PER). See Appendix B for recommended data reporting formats.

## 3.2 Radiated RF Tests

### 3.2.1 Test Set-up

The basic test set-up is similar to that for the conducted tests and is shown in Figure 3.2.

Figure 3.2 – Block Schematic Diagram – Radiated RF Tests for AP

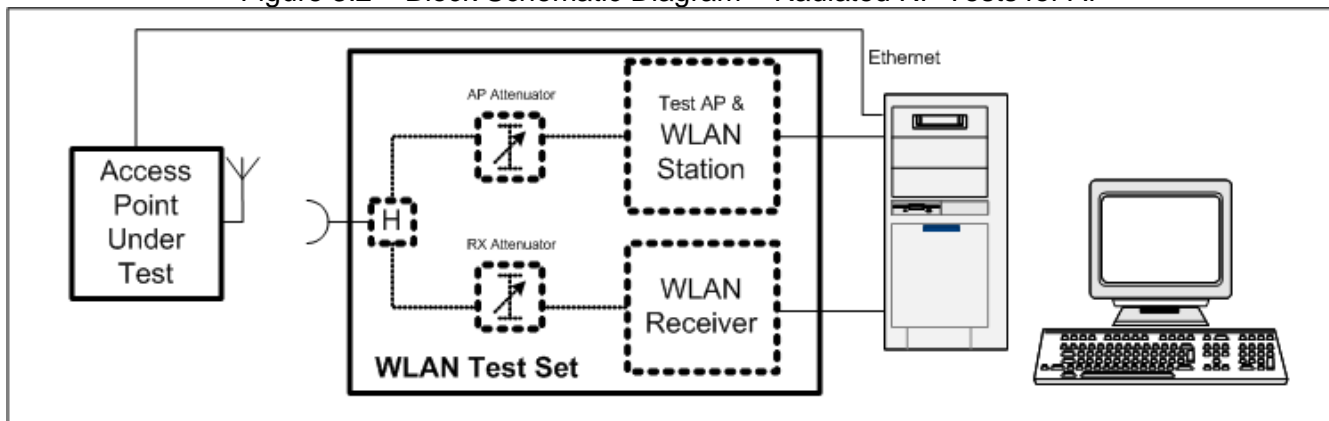

---

### **3.2.2**      **Equipment**

The APUT shall be provided with facilities that enable the Control PC to set the SSID, channel, modulation and data rate.

### **3.2.3**      **Radiated Power**

#### **3.2.3.1**      **Discussion**

The method used is similar to the conducted transmit measurement with the exception that the co-axial connection between the hybrid splitter and the APUT is now made using the APUT antenna(s) and a Validated test antenna. The radiated path loss, from the position of the APUT antenna(s), including the test antenna, shall be calibrated.

The procedure described below relates to each individual measurement and will need to be repeated for each position and data rate specified for the device under test.

#### **3.2.3.2**      **Unicast Test Packets**

The unicast test data packets shall be 200 frame bytes at a rate of 50 frames a second, to approximate a voice data stream.

#### **3.2.3.3**      **Test Procedure**

The procedure is identical to that of the conducted transmit power measurement. The settings for the AP and WLAN Receiver attenuators will be different due to extra loss of the radiated path.

The recommended procedure is:

1. The AP Attenuator is set such that the signal received at the WLAN APUT's antenna connector is at least 10dB higher than the sensitivity threshold.
2. The RX Attenuator, in the WLAN Test Set is set such that the received signal level from the APUT at the input of the WLAN Receiver is at least 10dB higher but not more than 50dB higher than the sensitivity threshold.
3. The AP under test (APUT) is set up to transmit on the desired channel, modulation and at the desired data rate.
4. The WLAN Station, in the WLAN Test Set, associates with the APUT.
5. The WLAN Station is set to continuously transmit unicast test data packets to the APUT, which responds with ACK control packets.
6. The WLAN Receiver reports the reception of the APUT ACK transmissions together with the data rate and the RSSI reading to the Control PC. Note the mean value of RSSI over a period of about 10 seconds.
7. Repeat steps 3 to 6 for each required channel and data rate.
8. Create a Table of Channel, Modulation, Data Rate and Mean RSSI for each measurement. See Appendix B for recommended data reporting formats.

Convert RSSI Readings:

9. Remove the APUT. Connect the APUT's antenna directly to a Vector Signal Generator capable of generating WLAN IEEE 802.11a/b/g frames.

10. Set the Signal Generator to send a WLAN ACK control frame, on the desired center frequency, with the correct modulation and data rate as per the first measurement in the Table created in step 8.
11. Set the WLAN Receiver to the same channel as the Signal Generator.
12. Monitor the RSSI reported by the WLAN Receiver.
13. Adjust the Signal Generator output level such that the RSSI reported by the WLAN Receiver is that recorded in the corresponding Receive Sensitivity measurement in the Table created in step 8, and record the Output Level of the Signal Generator, to the nearest dBm, in an extra column of the Table.

Note: To reduce the required output level of the Signal Generator, the RX Attenuator may be decreased in value and the difference accounted for in the tabulated results.

14. Repeat steps 10 - 13 for all the channels, modulations, and data rates in the Table created in Step 8.

#### 3.2.3.4 Results

The Results shall be in the form of a Table of Channel, Modulation, Data Rate, Mean RSSI, and Transmit Power dBm. See Appendix B for recommended data reporting formats.

### 3.2.4 Receive Sensitivity Measurement

#### 3.2.4.1 Discussion

The method used is similar to the conducted measurement with the exception that the co-axial connection between the hybrid splitter and the DUT is now made using the DUT antenna(s) and a calibrated test antenna. The radiated path loss from the position of the DUT antenna(s), including the test antenna, shall be calibrated.

#### 3.2.4.2 Unicast Test Packets

The unicast test data packets shall be 200 frame bytes at a rate of 50 frames a second, to approximate a voice data stream.

#### 3.2.4.3 Test Procedure

The recommended procedure is:

1. The AP Attenuator is set such that the signal received at the APUT antenna connector is about 10dB higher than the sensitivity threshold.
2. The RX Attenuator, in the WLAN Test Set is set such that the received signal level from the APUT at the input of the WLAN Receiver is at least 10dB higher but not more than 50dB higher than the sensitivity threshold.
3. The APUT is set up to transmit on the desired channel, modulation and data rate.
4. The WLAN Station, in the WLAN Test Set, associates with the APUT.
5. The WLAN Station is set to continuously transmit unicast data packets to the APUT.
6. The APUT will respond to the received unicast data packets with an ACK control frame.
7. The WLAN Receiver reports the reception of the ACK control frames to the Control PC
8. The Control PC counts the number of data frames and the number of ACK control frames received over a time period needed to receive 100 (TBR) data frames and the corresponding

---

ACKs. The frame reception rate (FRR) is computed as (# of ACKs received / # data frames transmitted)

9. The AP attenuator is increased, until the FRR reduces to the point where a 1dB increase causes the FRR to be less than 90%.
10. The AP Attenuator is decreased by 1dB and the value noted, "A"dB
11. Repeat steps 3 to 10 for each required channel, modulation and data rate.
12. Create a Table of Channel, Modulation, Data Rate, and AP Attenuator Setting. See Appendix B for recommended data reporting formats.

Convert the Test AP and AP Attenuator setting:

Convert the Test AP and AP Attenuator setting:

13. Measure the power level to an accuracy of 0.5dBm, "P"dBm as per the method described in Appendix C.
14. From the power level measured in step 13, add 10dB and deduct the value of the AP Attenuator noted in step 10, i.e.  $P + 10 - A$ . Record this value, the Receive Sensitivity, to an accuracy of 1dBm in an extra column to the Table created in step 12
15. Repeat steps 13 - 14 for all the channels, modulations, and data rates and used in the measurement taking.

#### 3.2.4.4 Results

The results shall be in the form of a Table of Channel, Modulation, Data Rate, AP Attenuator setting and Receive Sensitivity (10%PER). See Appendix B for recommended data reporting formats.

---

## 4. RADIATED MEASUREMENTS

### 4.1 Test Conditions for Device Under Test

The DUT shall be tested under conditions that most closely represent the actual working conditions of the device.

If the DUT is a handheld mobile device, then it should be placed on a turntable mounted on a SAM Head Phantom as described in Reference (1), or mounted for free space testing. See Appendix E for handheld product testing requirements.

If the DUT is an AP, it should be placed on its own on the turntable with the antennas in the vertical position, or as specified by the vendor.

If the DUT is a self contained Wi-Fi/Mobile Module with internal antennas, such as a PC Card, then the vendor may choose to

Either

- Supply the DUT together with one of its intended host platforms, e.g. a laptop computer. In this case, the combination should then be placed on the turntable and the results sheet should clearly state the combination that was used in the measurements.

Or

- Test the Module, on its own, mounted in a holder that orientates the module in the position that represents its normal use. In this case the results sheet should clearly state that the test did not include a host device.

Or

- Carry out both tests as above. This is the preferred method, but not mandatory.

If the DUT is a self contained Wi-Fi/Mobile Module without internal antennas, such as a mPCI Card, then the vendor must supply the complete device, which includes the antennas, for testing. No individual module testing is acceptable.

The test results shall include a description, and diagram or photograph of the test conditions used for the device under test.

## 5. MOBILE STATION TESTING

### 5.1 Transmitter Performance

#### 5.1.1 Conducted Power Output

##### 5.1.1.1 DUT Requirements

The DUT shall be provided to the Test Laboratory with the facility to connect directly to the RF test equipment. This may be via an existing antenna connector, or it may be a carefully modified unit to allow such connection. In the latter case, it is the responsibility of the supplier of the DUT to ensure that the connection is present and suitable.

##### 5.1.1.2 Frequency Channels

The measurements shall be taken at the lowest, middle<sup>9</sup> and highest channels supported by the device, in each of the 2.4GHz and 5GHz bands.

##### 5.1.1.3 Data Rates

On each frequency channel, the transmit power output shall be measured at the following data rates:

IEEE 802.11b	11Mbps
IEEE 802.11g	6, 11, 12 and 24Mbps
IEEE 802.11a	6, 12 and 24Mbps

##### 5.1.1.4 Not Used

##### 5.1.1.5 Results

Results should be represented in dBm and rounded to the closest integer value.

There is no pass / fail criteria.

### 5.1.2 Total Radiated Power (TRP)

#### 5.1.2.1 DUT Requirements

The DUT shall be provided in an unmodified state.

#### 5.1.2.2 Frequency Channels

For IEEE 802.11b/g devices the complete TRP measurement is made on Channel 6. Single point measurements are made on the highest and lowest supported channels. The selection of the location for the single point measurement should be chosen on a section of the radiation pattern that is smooth and at or near the maximum transmit power value.

<sup>9</sup> For 5 GHz bands refer to Appendix D for the middle channel numbers per sub band.

---

For IEEE 802.11a devices the complete TRP measurement is made on the lowest channel of the lowest supported band and on the highest channel of the highest supported band. Single point measurements are made on each sub band at the lowest, middle<sup>10</sup>, and highest channels. See Appendix D for examples of some commonly supported 5 GHz bands. The selection of the location, the “Reference Position”, for the single point measurement should be chosen on a section of the radiation pattern that is smooth and at or near the maximum transmit power value.

In each case where a complete TRP measurement is made it shall be reported as the Mode Radiated Figure of Merit. In each case where a single point measurement is made it shall be reported as a Mode Radiated Reference Measurement.

### 5.1.2.3 Data Rates

On each frequency channels, the transmit power output shall be measured at the following data rates:

IEEE 802.11b	11Mbps
IEEE 802.11g	6Mbps
IEEE 802.11a	6Mbps

### 5.1.2.4 Results

Results should be represented in dBm and rounded to the closest integer value.

Inferred TRP results from combinations not specifically tested can be derived using the table of conducted TX power results obtained in 5.1.1.5

There is no pass / fail criteria.

## 5.2 Receiver Performance

### 5.2.1 Conducted Receiver Sensitivity

#### 5.2.1.1 DUT Requirements

The DUT shall be provided with the facility to connect directly to the RF test equipment. This may be via an existing antenna connector, or it may be a carefully modified unit to allow such connection. In the latter case, it is the responsibility of the supplier of the DUT to ensure that the connection is present and suitable.

If the DUT is operating a combining diversity scheme then a combiner may be used such that the received signal is split between the antenna connections. In this case the splitter must be included when carrying out the validation procedure with the unused port being correctly terminated.

---

<sup>10</sup> Refer to Appendix D for the middle channel numbers per sub band.

---

### 5.2.1.2 Frequency Channels

The measurements shall be taken at the lowest, middle<sup>11</sup> and highest channels supported by the device, in each of the 2.4GHz and 5GHz bands

### 5.2.1.3 Data Rates

On each frequency channel, receive sensitivity shall be measured at the following data rates:

IEEE 802.11b	11Mbps
IEEE 802.11g	6, 11, 24 and 54Mbps
IEEE 802.11a	6, 24 and 54Mbps

### 5.2.1.4 Results

Results should be represented in dBm and rounded to the closest integer value.

There is no pass / fail criteria.

## **5.2.2 Total Isotropic Sensitivity (TIS)**

### 5.2.2.1 DUT Requirements

The DUT shall be provided in an unmodified state.

### 5.2.2.2 Frequency Channels

For IEEE 802.11b/g devices the complete TIS measurement is made on Channel 6. Single point measurements are made on the highest and lowest supported channels. The selection of the location, the "Reference Position", for the single point measurement should be chosen on a section of the radiation pattern that is smooth and at or near the maximum sensitivity value.

For IEEE 802.11a devices the complete TIS measurement is made on the lowest channel of the lowest supported band and on the highest channel of the highest supported band. Single point measurements are made on each sub band at the lowest, middle<sup>10</sup>, and highest channels. See Appendix D for examples of some commonly supported 5 GHz bands.. The selection of the location, the "Reference Position", for the single point measurement should be chosen on a section of the radiation pattern that is smooth and at or near the maximum sensitivity value.

In each case where a complete TIS measurement is made it shall be reported as the Mode Sensitivity Figure of Merit. In each case where a single point measurement is made it shall be reported as a Mode Sensitivity Reference Measurement.

### 5.2.2.3 Data Rates

On each frequency channels, receive sensitivity shall be measured at the following data rates:

---

<sup>11</sup> For 5 GHz bands refer to Appendix D for the middle channel numbers per sub band.



IEEE 802.11b	11Mbps
IEEE 802.11g	54Mbps
IEEE 802.11a	54Mbps

5.2.2.4 Results

Results should be represented in dBm and rounded to the closest integer value.

There is no pass / fail criteria.

**5.2.3 Radiated Receiver Sensitivity, Simultaneous Operation (Wi-Fi Desense)**

5.2.3.1 DUT Requirements

The DUT shall be provided in an unmodified state.

5.2.3.2 Positions

While conducting the simultaneous operation mode evaluation, the “Reference Position” for the corresponding Wi-Fi mode, as determined in Test 5.2.2, shall be used.

5.2.3.3 Highest Cellular Frequency Channel Test

The device shall be set to operate at the highest cellular channel supported.

The Wi-Fi channel and data rate shall be set as shown in Table 5.1:

Table 5.1 – Wi-Fi Channel and Data Rate for TIS Wi-Fi Desense

Wi-Fi Mode	Channel	Data Rate
IEEE 802.11b	6	11
IEEE 802.11g		54
IEEE 802.11a	Middle <sup>12</sup> of each supported band	54

The Radiated Receiver Sensitivity Degradation shall be measured and recorded.

5.2.3.4 Harmonic Interference Tests

Reference shall be made to Appendix A and Tables A.1 and A.2.

For each cellular system supported by the device, the possible harmonic interferences are identified in Tables A1 and A2 for the 2.4GHz and 5GHz Wi-Fi bands respectively.

<sup>12</sup> Refer to Appendix D for the middle channel numbers per sub band.

---

#### 5.2.3.4.1 *IEEE 802.11b and .11g*

If the device supports IEEE 802.11b or 802.11g, then for each supported combination of cellular system and regulatory domain, reference is made to Table A.1.

- For each supported combination cellular system and regulatory domain
  1. Check the column corresponding to that cellular system and regulatory domain
  2. If one or more possible harmonic interferences are shown, at supported WI-Fi channels or regulatory domain, then select one combination – if no combination or no supported combination is shown, no test is required.
  3. The Radiated Receiver Sensitivity Degradation shall be measured and recorded against that cellular system
- Select the next supported cellular system and regulatory domain and repeat steps 1, 2 and 3.

#### 5.2.3.4.2 *IEEE 802.11a*

If the device supports IEEE 802.11a, then for each supported combination of cellular system and regulatory domain, reference is made to Table A.2.

- For each supported combination cellular system and regulatory domain
  1. Check the column corresponding to that cellular system and regulatory domain
  2. If one or more possible harmonic interferences are shown, at supported WI-Fi channels or regulatory domain, then select one combination – if no combination or no supported combination is shown, no test is required.
  3. The Radiated Receiver Sensitivity Degradation shall be measured and recorded against that cellular system
- Select the next supported cellular system and regulatory domain and repeat steps 1, 2 and 3.

#### 5.2.3.5 Results

Results should be represented in dB and rounded to the closest integer value.

There is no pass / fail criteria.

### 5.2.4 **Radiated Cellular Receiver Sensitivity, Simultaneous Operation (Cellular Desense)**

#### 5.2.4.1 DUT Requirements

The DUT shall be provided in an unmodified state.

#### 5.2.4.2 DUT Polarization

While conducting the simultaneous operation measurement, the “Reference Polarization and Orientation” position for the corresponding Cellular mode, as determined in the Cellular TIS measurement, shall be used. There will be three polarization and orientation values, one for each of the three bands (low, middle, high) and the polarization used should be the one closest to the frequency being measured.

### 5.2.4.3 Wi-Fi Frequency

Devices that operate in the 2.4 GHz band will be set to operate on channel 6 ( $f_c = 2.437$  GHz). Devices that operate in the 5 GHz band will be set to operate on the mid channel of the appropriate sub-band supported as shown in Table 5.2:

Table 5.2 – Channel setting for Wi-Fi U-NII Band for TIS Cellular Desense

Sub Band	Mid Channel #	Mid Channel Center Frequency $f_c$
U-NII Lower Band (5.15 GHz to 5.25 GHz)	44	5.200 GHz
U-NII Middle Band (5.25 GHz to 5.35 GHz)	60	5.300 GHz
U-NII Upper Band (5.725 GHz to 5.825 GHz)	157	5.765 GHz
European ETSI Band	120	5.620 GHz

If the device has a dual band radio then two sets of cellular desense measurements are required.

The relative receiver Sensitivity Degradation shall be measured and recorded. All channels that are above the 5dB margin at the reference sensitivity polarization and orientation position need to be reported.

### 5.2.4.4 Cellular Technology and Frequency Band

The test shall be repeated for each technology and frequency band supported by the DUT, which may be any combination of the following:

- GSM at 850MHz (GSM 850)
- GSM at 900MHz (P-GSM 900)
- GSM at 1800MHz (DCS 1800)
- GSM at 1900MHz (PCS 1900)
- WCDMA at 850MHz (UTRA FDD Operating Band V)
- WCDMA at 1900MHz (UTRA FDD Operating Band II)
- WCDMA at 2100MHz (UTRA FDD Operating Band I)
- CDMA at 850MHz
- CDMA at 1900MHz

---

5.2.4.5 Results

Results should be recorded as % Digital Error Rate<sup>13</sup>. All channels that are above the 5dB margin at the reference sensitivity polarization need to be reported.

---

<sup>13</sup> Digital Error Rate is a generic term to refer to the appropriate error measuring scheme in 6.2 (CDMA – FER), 6.3 (TDMA – BER) and 6.3 (GSM – RBER) of the CTIA “Test Plan for Mobile Station Over The Air Performance”, Version 2.1.

---

## 6. ACCESS POINT TESTING

### 6.1 Transmitter Performance

#### 6.1.1 Conducted Power Output

##### 6.1.1.1 APUT Requirements

The APUT shall be provided to the Test Laboratory with the facility to connect directly to the RF test equipment. This may be via an existing antenna connector, or it may be a carefully modified unit to allow such connection. In the latter case, it is the responsibility of the supplier of the APUT to ensure that the connection is present and suitable.

##### 6.1.1.2 Frequency Channels

The measurements shall be taken at the lowest, middle<sup>14</sup> and highest channels supported by the device, in each of the 2.4GHz and 5GHz bands

##### 6.1.1.3 Data Rates

On each frequency channel, the transmit power output shall be measured at the following data rates:

IEEE 802.11b	11Mbps
IEEE 802.11g	6, 11, 12 and 24Mbps
IEEE 802.11a	6, 12 and 24Mbps

##### 6.1.1.4 Not Used

##### 6.1.1.5 Results

Results should be represented in dBm and rounded to the closest integer value.

There is no pass / fail criteria.

### 6.1.2 Total Radiated Power (TRP)

#### 6.1.2.1 APUT Requirements

The APUT shall be provided in an unmodified state.

#### 6.1.2.2 Frequency Channels

For IEEE 802.11b/g devices the complete TRP measurement is made on Channel 6. Single point measurements are made on the highest and lowest supported channels. The selection of the location, the "Reference Position", for the single point measurement should be chosen on a section of the radiation pattern that is smooth and at or near the maximum transmit power value.

---

<sup>14</sup> For 5 GHz bands refer to Appendix D for the middle channel numbers per sub band.

For IEEE 802.11a devices the complete TRP measurement is made on the lowest channel of the lowest supported band and on the highest channel of the highest supported band. Single point measurements are made on each sub band at the lowest, middle<sup>14</sup>, and highest channels. See Appendix D for examples of some commonly supported 5 GHz bands. The selection of the location, the “Reference Position”, for the single point measurement should be chosen on a section of the radiation pattern that is smooth and at or near the maximum transmit power value.

In each case where a complete TRP measurement is made it shall be reported as the Mode Radiated Figure of Merit. In each case where a single point measurement is made it shall be reported as a Mode Radiated Reference Measurement.

### 6.1.2.3 Data Rates

On each frequency channels, the transmit power output shall be measured at the following data rates:

IEEE 802.11b	11Mbps
IEEE 802.11g	6Mbps
IEEE 802.11a	6Mbps

### 6.1.2.4 Results

Results should be represented in dBm and rounded to the closest integer value.

Inferred TRP results from combinations not specifically tested can be derived using the table of conducted TX power results obtained in 5.1.1.5

There is no pass / fail criteria.

## 6.2 Receiver Performance

### 6.2.1 Conducted Receive Sensitivity

#### 6.2.1.1 APUT Requirements

The APUT shall be provided with the facility to connect directly to the RF test equipment. This may be via an existing antenna connector, or it may be a carefully modified unit to allow such connection. In the latter case, it is the responsibility of the supplier of the DUT to ensure that the connection is present and suitable.

If the APUT is operating a combining diversity scheme then a combiner may be used such that the received signal is split between the antenna connections. In this case the splitter must be included when carrying out the validation procedure with the unused port being correctly terminated.

#### 6.2.1.2 Frequency Channels

The measurements shall be taken at the lowest, middle<sup>15</sup> and highest channels supported by the device, in each of the 2.4GHz and 5GHz bands

---

<sup>15</sup> For 5 GHz bands refer to Appendix D for the middle channel numbers per sub band.

### 6.2.1.3 Data Rates

On each frequency channel, receive sensitivity shall be measured at the following data rates:

IEEE 802.11b	11Mbps
IEEE 802.11g	6, 11, 24 and 54Mbps
IEEE 802.11a	6, 24 and 54Mbps

### 6.2.1.4 Results

Results should be represented in dBm and rounded to the closest integer value.

There is no pass / fail criteria.

## **6.2.2 Total Isotropic Sensitivity (TIS)**

### 6.2.2.1 APUT Requirements

The APUT shall be provided in an unmodified state.

### 6.2.2.2 Frequency Channels

For IEEE 802.11b/g devices the complete TIS measurement is made on Channel 6. Single point measurements are made on the highest and lowest supported channels. The selection of the location for the single point measurement should be chosen on a section of the radiation pattern that is smooth and at or near the maximum sensitivity value.

For IEEE 802.11a devices the complete TIS measurement is made on the lowest channel of the lowest supported band and on the highest channel of the highest supported band. Single point measurements are made on each sub band at the lowest, middle<sup>16</sup>, and highest channels. See Appendix D for some commonly supported 5 GHz bands. The selection of the location for the single point measurement should be chosen on a section of the radiation pattern that is smooth and at or near the maximum sensitivity value.

In each case where a complete TIS measurement is made it shall be reported as the Mode Sensitivity Figure of Merit. In each case where a single point measurement is made it shall be reported as a Mode Sensitivity Reference Measurement.

### 6.2.2.3 Data Rates

On each frequency channels, receive sensitivity shall be measured at the following data rates:

IEEE 802.11b	11Mbps
IEEE 802.11g	54Mbps

<sup>16</sup> Refer to Appendix D for the middle channel number per sub band.

---

IEEE 802.11a

54Mbps

6.2.2.4 Results

Results should be represented in dBm and rounded to the closest integer value.

There is no pass / fail criteria.



## 7. WLAN TEST SET

### 7.1 Estimated Signal Levels

The estimated signal levels for the various tests are tabulated in Tables 7.1 to 7. 4. From these Tables the requirements for the Test AP TX Power, RX Attenuator and AP Attenuator can be calculated.

Table 7.1 – Conducted TX Test

	5GHz	2.4GHz	
	OFDM	OFDM	CCK
DUT Min Sensitivity, dBm	-65	-65	-76
Margin, dB	10	10	10
Cable loss, dB	6	6	6
Hybrid loss, dB	4	4	4
<b>Required Test AP TX Power, dBm</b>	<b>-45</b>	<b>-45</b>	<b>-56</b>

DUT Min TX Power, dBm	17	17	17
DUT Min Antenna Gain, dB	-10	-10	-10
Margin, dB	10	10	10
Cable loss, dB	6	6	6
Hybrid loss, dB	4	4	4
RX Signal at RX Attn, dBm	-13	-13	-13
WLAN RX Min Sensitivity, dBm	-68	-68	-76
<b>RX Attn setting, dB</b>	<b>55</b>	<b>55</b>	<b>63</b>

Table 7.2 – Conducted RX Test

	5GHz	2.4GHz	
	OFDM	OFDM	PSK
DUT Max Sensitivity, dBm	-90	-90	-95
Cable loss, dB	6	6	6
Hybrid loss, dB	4	4	4
<b>Required Test AP TX Power, dBm</b>	<b>-80</b>	<b>-80</b>	<b>-85</b>

DUT Max TX Power, dBm	23	23	23
DUT Max Antenna Gain, dB	0	0	0
Margin, dB	10	10	10
Cable loss, dB	6	6	6
Hybrid loss, dB	4	4	4
RX Signal at RX Attn, dBm	3	3	3
WLAN RX Min Sensitivity, dBm	-68	-68	-76
<b>RX Attn setting, dB</b>	<b>71</b>	<b>71</b>	<b>79</b>

Table 7.3 – Radiated TX Test

	5GHz	2.4GHz	
	OFDM	OFDM	CCK
DUT Min Sensitivity, dBm	-65	-65	-76
Margin, dB	10	10	10
Required signal level, dBm	-55	-55	-66
Distance, m	3.6	1.5	1.5
Path Loss, dB	57.9	43.6	43.6
Test Antenna Gain, dB	10	10	10
Min DUT Antenna Gain, dB	-10	-10	-10
Cable loss, dB	3	3	3
Hybrid loss, dB	4	4	4
<b>Required Test AP TX Power, dBm</b>	<b>9.9</b>	<b>-4.4</b>	<b>-15.4</b>

DUT Min TX Power, dBm	17	17	17
DUT Min Antenna Gain, dB	-10	-10	-10
Test Antenna Gain, dB	10	10	10
Path Loss, dB	57.9	43.6	43.6
Margin, dB	10	10	10
Cable loss, dB	3	3	3
Hybrid loss, dB	4	4	4
RX Signal at RX Attn, dBm	-57.9	-43.6	-43.6
WLAN RX Min Sensitivity, dBm	-68	-68	-76
<b>RX Attn setting, dB</b>	<b>10.1</b>	<b>24.4</b>	<b>32.4</b>

Table 7.4 – Radiated RX Test

	5GHz	2.4GHz	
	OFDM	OFDM	PSK
DUT Max Sensitivity, dBm	-90	-90	-95
DUT Min Antenna Gain, dB	-10	-10	-10
Distance, m	3.6	1.5	1.5
Path Loss, dB	57.9	43.6	43.6
Test Antenna Gain, dB	10	10	10
Cable loss, dB	3	3	3
Hybrid loss, dB	4	4	4
<b>Required Test AP TX Power, dBm</b>	<b>-25.1</b>	<b>-39.4</b>	<b>-44.4</b>

DUT Min TX Power, dBm	17	17	17
DUT Min Antenna Gain, dB	0	0	0
Test Antenna Gain, dB	10	10	10
Path Loss, dB	57.9	43.6	43.6
Margin, dB	10	10	10
Cable loss, dB	3	3	3
Hybrid loss, dB	4	4	4
RX Signal at RX Attn, dBm	-67.9	-53.6	-53.6
WLAN RX Min Sensitivity, dBm	-68	-68	-76
<b>RX Attn setting, dB</b>	<b>0.1</b>	<b>14.4</b>	<b>22.4</b>

From these Tables, the following can be calculated:

- AP Attenuator  
The maximum required Test AP transmit Power is 9.9dBm and the minimum –85dBm  
Hence the AP Attenuator will need to be at least 95dB
- RX Attenuator  
The maximum required attenuation is 79dB, and the minimum is 0dB.

## 7.2 Test AP and WLAN Station Requirements

### 7.2.1 Basic Parameters

The Test AP does not require support for encryption, fragmentation or QoS. In addition the Test AP will be set to not support APSD.

### 7.2.2 RF Parameters

The basic RF requirements for the Test AP are:

Standards IEEE 802.11a, 802.11b, 802.11g

Signal Rate	<p>For IEEE 802.11a/g</p> <ul style="list-style-type: none"> <li>• 54, 48, 36, 24, 18, 12, 9, 6Mbps</li> </ul> <p>For IEEE 802.11b</p> <ul style="list-style-type: none"> <li>• 11, 5.5, 2, 1Mbps</li> </ul>
Wireless Frequency Range	<p>2.412 to 2.484GHz 4.915 to 5.32 GHz and 5.5 to 5.805GHz</p>
Radio and Modulation Type	<p>For IEEE 802.11b and 802.11g DSSS</p> <ul style="list-style-type: none"> <li>• DBPSK @ 1Mbps</li> <li>• DQPSK @ 2Mbps</li> <li>• CCK @ 5.5 and 11Mbps</li> </ul> <p>For IEEE 802.11a and 802.11g OFDM</p> <ul style="list-style-type: none"> <li>• BPSK @ 6 and 9Mbps</li> <li>• QPSK @ 12 and 18Mbps</li> <li>• 16QAM @ 24 and 36Mbps</li> <li>• 64QAM @ 48 and 54Mbps</li> </ul>
Minimum Receive Sensitivity	<p>For IEEE 802.11a and 802.11g</p> <ul style="list-style-type: none"> <li>• 6Mbps: -82dBm</li> <li>• 9Mbps: -81dBm</li> <li>• 12Mbps: -79dBm</li> <li>• 18Mbps: -77dBm</li> <li>• 24Mbps: -74dBm</li> <li>• 36Mbps: -70dBm</li> <li>• 48Mbps: -66dBm</li> <li>• 54Mbps: -65dBm</li> </ul> <p>For IEEE 802.11b and 802.11g</p> <ul style="list-style-type: none"> <li>• 1Mbps: -86dBm</li> <li>• 2Mbps: -83dBm</li> <li>• 5.5Mbps: -79dBm</li> <li>• 11Mbps: -76dBm</li> </ul>
Maximum Transmit Output Power	Not less than 10dB at all frequencies and data rates
Transmit Relative Constellation Error	<p>For OFDM</p> <ul style="list-style-type: none"> <li>• 54Mbps: not to exceed -30dB</li> <li>• 48Mbps: not to exceed -27dB</li> <li>• 36Mbps: not to exceed -24dB</li> <li>• 24Mbps: not to exceed -21dB</li> <li>• 18Mbps: not to exceed -18dB</li> <li>• 12Mbps: not to exceed -15dB</li> <li>• 9Mbps: not to exceed -13dB</li> <li>• 6Mbps: not to exceed -10dB</li> </ul>

### 7.3 WLAN Receiver RF Requirements

The basic RF requirements for the WLAN Receiver are:

Standards	IEEE 802.11a, IEEE 802.11b, IEEE 802.11g
Signal Rate	For IEEE 802.11a/g

Wireless Frequency Range	<ul style="list-style-type: none"> <li>• 54, 48, 36, 24, 18, 12, 9, 6Mbps</li> </ul> <p>For IEEE 802.11b</p> <ul style="list-style-type: none"> <li>• 11, 5.5, 2, 1Mbps</li> </ul> <p>2.412 to 2.484GHz</p>
Radio and Modulation Type	<p>4.915 to 5.32 GHz and 5.5 to 5.805GHz</p> <p>For IEEE 802.11b and 802.11g</p> <p>DSSS</p> <ul style="list-style-type: none"> <li>• DBPSK @ 1Mbps</li> <li>• DQPSK @ 2Mbps</li> <li>• CCK @ 5.5 and 11Mbps</li> </ul> <p>For IEEE 802.11a and 802.11g</p> <p>OFDM</p> <ul style="list-style-type: none"> <li>• BPSK @ 6 and 9Mbps</li> <li>• QPSK @ 12 and 18Mbps</li> <li>• 16QAM @ 24 and 36Mbps</li> <li>• 64QAM @ 48 and 54Mbps</li> </ul>
Minimum Receive Sensitivity	<p>For IEEE 802.11a and 802.11g</p> <ul style="list-style-type: none"> <li>• 6Mbps: -86dBm</li> <li>• 9Mbps: -84dBm</li> <li>• 12Mbps: -82dBm</li> <li>• 18Mbps: -80dBm</li> <li>• 24Mbps: -77dBm</li> <li>• 36Mbps: -73dBm</li> <li>• 48Mbps: -69dBm</li> <li>• 54Mbps: -68dBm</li> </ul> <p>For IEEE 802.11b and 802.11g</p> <ul style="list-style-type: none"> <li>• 1Mbps: -86dBm</li> <li>• 2Mbps: -83dBm</li> <li>• 5.5Mbps: -79dBm</li> <li>• 11Mbps: -76dBm</li> </ul>
RSSI Reporting	<p>For signal levels &gt;10dB and &lt;50dB above Minimum Receive Sensitivity the reported RSSI shall be reported in steps of no more than 0.5dBm.</p> <p>Measurement of RSSI shall be in a time period equal or less than 800ns (one period of the OFDM short training symbol).</p>

## 7.4 Attenuator Requirements

Minimum Frequency Range	2 to 6GHz
Minimum Attenuation	0dB
Maximum Attenuation	Not less than 100dB
Step	1dB
Attenuator Accuracy	0.25dB
Impedance	50ohms nominal
Maximum Input power	Not less than 23dBm

---

Note: For example, the attenuator could consist of two separate switched or programmable attenuators in series; 0-100dB in 10dB steps, and 0-10dB in 1 dB steps.

## 8. APPENDIX A – HARMONIC INTERFERENCE SELECTION MATRICIES

The following matrices are to be used for the selection of WLAN / Mobile Device Interference channel pairs. These modes are used in section 5.2.3.4 based upon which modes of operation. All frequencies quoted in the Appendix A Tables are in MHz.

Table A.1 – IEEE 802.11b/g Products<sup>a</sup>

Wi-Fi		GSM 850		GSM 900		GSM 1800		GSM 1900		CDMA-2000 US/Korea 800 MHz		CDMA-2000 UK 900 MHz		CDMA-2000 Korea 1700MHz		CDMA 2000 US 1900 MHz		UTRA FDD Band I – IV		UTRA TDD All Bands		PHS Asia		iDen 800 MHz	
Chan	Freq	Chan	Freq	Chan	Freq	Chan	Freq	Chan	Freq	Chan	Freq	Chan	Freq	Chan	Freq	Chan	Freq	Chan	Freq	Chan	Freq	Chan	Freq	Chan	Freq
1	2412																							1	806.025
2	2417																							1	806.025
3	2422																							53	807.325
4	2427																							120	809.000
5	2432																							187	810.675
6	2437																							253	812.325
7	2442																							320	814.000
8	2447																							387	815.675
9	2452																							453	817.325
10	2457																							520	819.000
11	2462									991	824.04													587	820.675
12	2467									991	824.04														
13	2472	128	824.2							1	825.03							4132 <sup>b</sup>	826.4						
										991	824.04														
14	2484																	4162 <sup>c</sup>	832.4						

Notes:

- a) Interference is caused by 3<sup>rd</sup> harmonic of the other technology
- b) UTRA FDD Band V Americas
- c) UTRA FDD Band VI Japan



Table A.2 – IEEE 802.11a Products

Wi-Fi		GSM 850		GSM 900		GSM 1800		GSM 1900		CDMA-2000 US/Korea 800 MHz		CDMA-2000 UK 900 MHz		CDMA-2000 Korea 1700MHz		CDMA 2000 US 1900 MHz		UTRA FDD Band I – IV		UTRA TDD All Bands		PHS Asia		iDen 800 MHz	
Chan	Freq	Chan	Freq	Chan	Freq	Chan	Freq	Chan	Freq	Chan	Freq	Chan	Freq	Chan	Freq	Chan	Freq	Chan	Freq	Chan	Freq	Chan	Freq	Chan	Freq
7	5035																	4196 <sup>e</sup>	839.2						
8	5040																	4200 <sup>e</sup>	840.0						
36	5180					594	1726.6											8633 <sup>e</sup>	1726.6						
40	5200					628	1733.4											8667 <sup>e</sup>	1733.4						
44	5220					661	1740.0					1329	872.0125					8700 <sup>e</sup>	1740.0						
48	5240					694	1746.6					1382	873.3375	0	1750.00			8733 <sup>e</sup>	1746.6						
52	5260					728	1753.4					1515	876.6625	67	1753.35			8767 <sup>e</sup>	1753.4						
56	5280			975	880.2	761	1760.0					1648	879.9875	200	1760.00			8800 <sup>d</sup>	1760.0						
60	5300			991	883.4	794	1766.6					1782	883.3375	333	1766.65			8833 <sup>d</sup>	1766.6						
64	5320			1007	886.6	828	1773.4					1915	866.6625	467	1773.35			8867 <sup>d</sup>	1773.4						
100	5500											1000	914.9875												
112	5560							528	1853.4							67	1853.35	9267 <sup>b</sup>	1853.4	9267 <sup>g</sup>	1853.4				
116	5580							561	1860.0							200	1860.00	9300 <sup>b</sup>	1860.0	9300 <sup>g</sup>	1860.0				
120	5600							594	1866.6							333	1866.65	9333 <sup>b</sup>	1866.6	9333 <sup>g</sup>	1866.6				
124	5620							628	1873.4							467	1873.35	9367 <sup>b</sup>	1873.4	9367 <sup>g</sup>	1873.4				
128	5640							661	1880.0							600	1880.00	9400 <sup>b</sup>	1880.0	9400 <sup>g</sup>	1880.0				
132	5660							694	1886.6							733	1886.65	9433 <sup>b</sup>	1886.6	9433 <sup>g</sup>	1886.6				
136	5680							728	1893.4							867	1893.35	9467 <sup>b</sup>	1893.4	9467 <sup>g</sup>	1893.4	1	1895.15		
140	5700							761	1900.0							1000	1900.00	9500 <sup>b</sup>	1900.0	9500 <sup>g</sup>	1900.0	17	1899.95		
149	5745																			9504 <sup>j</sup>	1900.8				
153	5765																			9512 <sup>j</sup>	1902.4				
157	5785																			9575 <sup>ij</sup>	1915.0				
161	5805																			9596 <sup>j</sup>	1919.2				
165	5825																			9608 <sup>i</sup>	1921.6				
196	4980																			9642 <sup>ak</sup>	1928.4				
																				9654 <sup>l</sup>	1932.4				
																				9662 <sup>h</sup>	1932.4				
																				9675 <sup>a</sup>	1935.0				
																				9675 <sup>h</sup>	1935.0				
																				9708 <sup>a</sup>	1941.6				
																				9708 <sup>h</sup>	1941.6				
																				4150 <sup>e</sup>	830.0				

Notes:

- a) UTRA FDD Band I ROW
- b) UTRA FDD Band II Americas
- c) UTRA FDD Band III ROW and UTRA FDD Band IV Americas
- d) UTRA FDD Band III ROW
- e) UTRA FDD Band VI Japan including 10MHz channels
- f) UTRA TDD ROW (1900-1920)
- g) UTRA TDD Americas (1850-1910) including LCR
- h) UTRA TDD Americas (1930-1990) including LCR
- i) UTRA TDD Americas (1910 – 1930) including LCR
- j) UTRA TDD LCR ROW (1900 – 1920)
- k) UTRA TDD LCR Americas (1910-1930)
- l) UTRA TDD LCR Americas (1930-1990)

## 9. APPENDIX B – SUMMARY TEST REPORT

Table B.1 – Sample Summation

Manufacturer	
Model	
Wi-Fi Alliance CID <sup>17</sup>	
CTIA Request #	
Serial Number/ESN/IMEI	
FCC ID Number	
Hardware Version	
Software Version	

### TEST 5.1.1 and 6.1.1. Conducted Power Output

Table B.2 – Conducted Power Output Results

Mode	Channel	Data rate, Mbps	Result, dBm	Comments	
IEEE 802.11b	Low	11			
	Mid	11			
	High	11			
IEEE 802.11g	Low	6			
		11			
		12			
		24			
	Mid	6			
		11			
		12			
		24			
	High	6			
		11			
		12			
		24			
IEEE 802.11a	Low	6			
		12			
		24			
	Mid <sup>18</sup>	6			
		12			
		24			
	High	6			
		12			
		24			

<sup>17</sup> Vendor supplies the Wi-Fi Alliance CID (Certification Identifier) during the CWG application process.

<sup>18</sup> Refer to Appendix D for the middle channel numbers per sub band.

**TEST 5.1.2 and 6.1.2**

**Total Radiated Power (TRP) – Mode Radiated Figure of Merit**

Table B.3 – Mode Radiated Figure of Merit Results

Mode	Channel	Data rate, Mbps	Result, dBm TRP	Comments
IEEE 802.11b	6	11		Calculated as per Reference (1)
IEEE 802.11g	6	6		Calculated as per Reference (1)
IEEE 802.11a	Lowest Channel of Lowest supported band	6		Calculated as per Reference (1)
IEEE 802.11a	Highest Channel of Highest supported band	6		Calculated as per Reference (1)

**Radiated Reference Measurements**

Table B.4 – Radiated Reference Measurements Results

Mode	Channel	Data rate, Mbps	Reference Position		Transmit Power, dBm	Comments
			Theta	Phi		
IEEE 802.11b	6	11				
	Low	11				
	High	11				
IEEE 802.11g	6	6				
	Low	6				
	High	6				
IEEE 802.11a	Lowest Channel of Lowest Supported Band	6				

	Middle Channel of Lowest Supported Band		6				
	Highest Channel of Lowest Supported Band		6				
	Lowest Channel of Next Supported Band		6				
	Middle Channel of Next Supported Band		6				
	Highest Channel of Next Supported Band		6				
	Lowest Channel of Next Supported Band		6				
	Middle Channel of Next Supported Band		6				
	Highest Channel of Next Supported Band		6				
	Lowest Channel of Highest Supported Band		6				
	Middle Channel of Highest Supported Band		6				
	Highest Channel of Highest Supported Band		6				

**TEST 5.2.1 and 6.2.1 Conducted Receiver Sensitivity**

Table B.5 – Conducted Receiver Sensitivity Results

Mode	Channel	Data rate, Mbps	Result, dBm	Comments	
IEEE 802.11b	Low	11			
	Mid	11			
	High	11			
IEEE 802.11g	Low	6			
		11			
		24			
		54			
	Mid	6			
		11			
		24			
		54			
	High	6			
		11			
		24			
		54			
IEEE 802.11a	Low	6			
		24			
		54			
	Mid <sup>19</sup>	6			
		24			
		54			
	High	6			
		24			
		54			

<sup>19</sup> Refer to Appendix D for the middle channel numbers per sub band.

**TEST 5.2.2 and 6.2.2 Total Isotropic Sensitivity (TIS)**

**Total Isotropic Sensitivity (TIS) – Mode Sensitivity Figure of Merit**

Table B.6 – Mode Sensitivity Figure of Merit Results

Mode	Channel	Data rate, Mbps	Result, dBm TIS	Comments
IEEE 802.11b	6	11		Calculated as per Reference (2)
IEEE 802.11g	6	54		Calculated as per Reference (2)
IEEE 802.11a	Lowest Channel of Lowest supported band	54		Calculated as per Reference (2)
IEEE 802.11a	Highest Channel of Highest supported band	54		Calculated as per Reference (1)

**Sensitivity Reference Measurements**

Table B.7 – Sensitivity Reference Measurements Results

Mode	Channel		Data rate, Mbps	Reference Position		Sensitivity, dBm	Comments
				Theta	Phi		
IEEE 802.11b	6		11				
	Low		11				
	High		11				
IEEE 802.11g	6		54				
	Low		54				
	High		54				
IEEE 802.11a	Lowest Channel of Lowest Supported Band		54				
	Middle Channel of Lowest Supported Band		54				
	Highest Channel of Lowest Supported Band		54				
	Lowest Channel of Next Supported Band		54				
	Middle Channel of Next Supported Band		54				
	Highest Channel of Next Supported Band		54				

	Lowest Channel of Next Supported Band		54				
	Middle Channel of Next Supported Band		54				
	Highest Channel of Next Supported Band		54				
	Lowest Channel of Highest Supported Band		54				
	Middle Channel of Highest Supported Band		54				
	Highest Channel of Highest Supported Band		54				



**TEST 5.2.3 Radiated Receiver Sensitivity, Simultaneous Operation (Wi-Fi Desense)**  
**Desensitization Reference Measurements**

**Test 5.2.3.3 Highest Cellular Frequency Channel Test**

Table B.8 – Highest Cellular Frequency Channel Test Results

802.11		Highest Cellular Frequency		802.11 Data rate, Mbps	Reference Position		Desense dB	Comments
Mode	Chan	Mode	Chan		Theta	Phi		
IEEE 802.11b	6			11				
IEEE 802.11g	6			54				
IEEE 802.11a	Mid			54				

**Test 5.2.3.4 Harmonic Interference Tests**

Table B.9 – Harmonic Interference Tests Results 802.11b&g

802.11		Cellular		802.11 Data rate, Mbps	Reference Position		Desense, dB	Comments	
Mode	Channel	Cellular Mode	Chan		Theta	Phi			
IEEE 802.11 b				11					
IEEE 802.11 g				54					

Table B.10 – Harmonic Interference Tests Results 802.11a

802.11		Cellular		802.11 Data rate, Mbps	Reference Position		Desense, dB	Comments	
Mode	Chan	Mode	Chan		Theta	Phi			
IEEE 802.11a				54					

**Test 5.2.4 Relative Receiver Sensitivity, Simultaneous Operation (Cellular Desense)**

**5.2.4.1 Wi-Fi 2.4 GHz Band**

Table B.11 – Cellular Desense Test Results for 802.11b&g Operation

Cellular Technology XXXX	Wi-Fi Channel	Reference Position Theta°	Reference Position Phi°	FER %	Comments
Low	802.11b/g Ch. 6 (2.437GHz)				
Low + 500 kHz	802.11b/g Ch. 6 (2.437GHz)				
Low + 1000 kHz	802.11b/g Ch. 6 (2.437GHz)				
Low + 1500 kHz	802.11b/g Ch. 6 (2.437GHz)				
Low + 2000 kHz	802.11b/g Ch. 6 (2.437GHz)				
Low + 2500 kHz	802.11b/g Ch. 6 (2.437GHz)				
Low + 3000 kHz	802.11b/g Ch. 6 (2.437GHz)				
Low + 3500 kHz	802.11b/g Ch. 6 (2.437GHz)				
Low + xxxx kHz	802.11b/g Ch. 6 (2.437GHz)				

**5.2.4.2 Wi-Fi U-NII Middle Band GHz Band**

Table B.12 – Cellular Desense Test Results for 802.11a Operation

Cellular Technology XXXX	Wi-Fi Channel	Reference Position Theta°	Reference Position Phi°	FER %	Comments
Low	802.11a Ch. 60 (5.300 GHz)				
Low + 500 kHz	802.11a Ch. 60 (5.300 GHz)				
Low + 1000 kHz	802.11a Ch. 60 (5.300 GHz)				
Low + 1500 kHz	802.11a Ch. 60 (5.300 GHz)				
Low + 2000 kHz	802.11a Ch. 60 (5.300 GHz)				
Low + 2500 kHz	802.11a Ch. 60 (5.300 GHz)				
Low + 3000 kHz	802.11a Ch. 60 (5.300 GHz)				
Low + 3500 kHz	802.11a Ch. 60 (5.300 GHz)				
Low + xxxx kHz	802.11a Ch. 60 (5.300 GHz)				

---

## 10. APPENDIX C – RF POWER MEASUREMENT

The following method shall be used in the conversion of the Test AP and AP Attenuator settings to a power level in dBm.

1. Remove the DUT and connect in its place the input of a matched diode detector or equivalent thereof. The output of the detector shall be connected to the vertical channel of an oscilloscope.
  - a. The combination of the diode detector and the oscilloscope shall be capable of faithfully reproducing the duty cycle of the transmitted output signal.
  - b. The observed duty cycle (Tx on / Tx on + off) shall be noted as  $x$  ( $0 < x \leq 1$ ).
2. Replace the matched diode detector with a wideband calibrated RF power meter with a matched thermocouple detector or an equivalent thereof and with an integration period that exceeds the repetition period of the transmitter by a factor 5 or more.
3. Set the Test AP to transmit on the same channel, modulation and data rate as the first row of the Table created in step 11.
4. Set the AP Attenuator to 10dB.
5. Set the AP to continuously transmit unicast data packets.
6. Measure the power level, "A"dBm.
7. Record the power level, to an accuracy of 0.5dBm, "P"dBm where  $P = A + 10 \log (1/x)$  dBm.

Note: This test procedure is similar to that specified in ETSI EN 301 893 V1.3.1.

## 11. APPENDIX D – IEEE 802.11A SUPPORTED CHANNEL OPTION EXAMPLES

Sub Band	Channel Range	Comments	TIS/TRP Channel	Reference Channel	Middle Channel Number
<b>Option One – All UNII Bands</b>					
UNII Low Band	36 to 48	Lowest Band	36	(36), 44, 48	44
UNII Middle Band	52 to 64	Next Highest Band	-	52, 60, 64	60
UNII Upper Band	149 to 161	Highest Band	161	149, 157, (161)	157
<b>Option Two – All UNII and ETSI Bands</b>					
UNII Low Band	36 to 48	Lowest Band	36	(36), 44, 48	44
UNII Middle Band	52 to 64	Next Highest Band	-	52, 60, 64	60
ETSI European band	100 to 140	Next Highest Band	-	100, 120, 140	120
UNII Upper Band	149 to 161	Highest Band	161	149, 157, (161)	157
<b>Option Three – ETSI Band Only</b>					
ETSI European band	100 to 140	One Band	100, 140	(100), 120, (140)	120
<b>Option Four – All UNII Bands and Channel 165</b>					
UNII Low Band	36 to 48	Lowest Band	36	(36), 44, 48	44
UNII Middle Band	52 to 64	Next Highest Band	-	52, 60, 64	60
UNII Upper Band	149 to 161	Next Highest Band	-	149, 157, 161	157
USA	165	Highest Band	165	(165)	-
<b>Option Five - Lower Two UNII Bands</b>					
UNII Low Band	36 to 48	Lowest Band	36	(36), 44, 48	44
UNII Mid Band	52 to 64	Highest Band	64	52, 60, (64)	60

## 12. APPENDIX E – DEVICE TESTING CONFIGURATIONS

Converged handheld devices that have moveable keyboards shall be tested with keyboard open, closed, or any other operational configurations as outlined in the table below.

<b>Device Capabilities</b>	<b>TIS/TRP</b>	<b>Tx/Rx Reference</b>	<b>Wi-Fi Desense</b>	<b>Cellular Desense</b>
<b>Wi-Fi Browser + Cellular Voice</b>	Free Space with all intended mechanical modes (including keyboard closed)	Free Space with all intended mechanical modes (including keyboard closed)	Free Space with one operational mechanical mode (preferably slider closed)	Free Space with one operational mechanical mode (preferably slider closed)
<b>Wi-Fi Browser + Wi-Fi VoIP + Cellular Voice</b>	SAM Right Ear with one mechanical position supporting Wi-Fi VoIP (keyboard closed) + Free Space with all intended mechanical modes (including keyboard closed)	SAM Right Ear with one mechanical position supporting Wi-Fi VoIP (keyboard closed) + Free Space with all intended mechanical modes (including keyboard closed)	Free Space with one operational mechanical mode (preferably slider closed)	Free Space with one operational mechanical mode (preferably slider closed)

Note: Mechanical modes can mean keyboard slider in all positions; open, closed, slider half rotated 90°, or other keyboard positions depending on product configuration.

- End -

## 射频和天线设计培训课程推荐

易迪拓培训([www.edatop.com](http://www.edatop.com))由数名来自于研发第一线的资深工程师发起成立,致力并专注于微波、射频、天线设计研发人才的培养;我们于 2006 年整合合并微波 EDA 网([www.mweda.com](http://www.mweda.com)),现已发展成为国内最大的微波射频和天线设计人才培养基地,成功推出多套微波射频以及天线设计经典培训课程和 ADS、HFSS 等专业软件使用培训课程,广受客户好评;并先后与人民邮电出版社、电子工业出版社合作出版了多本专业图书,帮助数万名工程师提升了专业技术能力。客户遍布中兴通讯、研通高频、埃威航电、国人通信等多家国内知名公司,以及台湾工业技术研究院、永业科技、全一电子等多家台湾地区企业。

易迪拓培训推荐课程列表: <http://www.edatop.com/peixun/tuijian/>



### 射频工程师养成培训课程套装

该套装精选了射频专业基础培训课程、射频仿真设计培训课程和射频电路测量培训课程三个类别共 30 门视频培训课程和 3 本图书教材;旨在引领学员全面学习一个射频工程师需要熟悉、理解和掌握的专业知识和研发设计能力。通过套装的学习,能够让学员完全达到和胜任一个合格的射频工程师的要求...

课程网址: <http://www.edatop.com/peixun/rfe/110.html>

### 手机天线设计培训视频课程

该套课程全面讲授了当前手机天线相关设计技术,内容涵盖了早期的外置螺旋手机天线设计,最常用的几种手机内置天线类型——如 monopole 天线、PIFA 天线、Loop 天线和 FICA 天线的设计,以及当前高端智能手机中较常用的金属边框和全金属外壳手机天线的设计;通过该套课程的学习,可以帮助您快速、全面、系统地学习、了解和掌握各种类型的手机天线设计,以及天线及其匹配电路的设计和调试...

课程网址: <http://www.edatop.com/peixun/antenna/133.html>



### WiFi 和蓝牙天线设计培训课程

该套课程是李明洋老师应邀给惠普 (HP)公司工程师讲授的 3 天员工内训课程录像,课程内容是李明洋老师十多年工作经验积累和总结,主要讲解了 WiFi 天线设计、HFSS 天线设计软件的使用,匹配电路设计调试、矢量网络分析仪的使用操作、WiFi 射频电路和 PCB Layout 知识,以及 EMC 问题的分析解决思路等内容。对于正在从事射频设计和天线设计领域工作的您,绝对值得拥有和学习!...

课程网址: <http://www.edatop.com/peixun/antenna/134.html>





## CST 学习培训课程套装

该培训套装由易迪拓培训联合微波 EDA 网共同推出,是最全面、系统、专业的 CST 微波工作室培训课程套装,所有课程都由经验丰富的专家授课,视频教学,可以帮助您从零开始,全面系统地学习 CST 微波工作的各项功能及其在微波射频、天线设计等领域的设计应用。且购买该套装,还可超值赠送 3 个月免费学习答疑...

课程网址: <http://www.edatop.com/peixun/cst/24.html>



## HFSS 学习培训课程套装

该套课程套装包含了本站全部 HFSS 培训课程,是迄今国内最全面、最专业的 HFSS 培训教程套装,可以帮助您从零开始,全面深入学习 HFSS 的各项功能和在多个方面的工程应用。购买套装,更可超值赠送 3 个月免费学习答疑,随时解答您学习过程中遇到的棘手问题,让您的 HFSS 学习更加轻松顺畅...

课程网址: <http://www.edatop.com/peixun/hfss/11.html>

## ADS 学习培训课程套装

该套装是迄今国内最全面、最权威的 ADS 培训教程,共包含 10 门 ADS 学习培训课程。课程是由具有多年 ADS 使用经验的微波射频与通信系统设计领域资深专家讲解,并多结合设计实例,由浅入深、详细而又全面地讲解了 ADS 在微波射频电路设计、通信系统设计和电磁仿真设计方面的内容。能让您在最短的时间内学会使用 ADS,迅速提升个人技术能力,把 ADS 真正应用到实际研发工作中去,成为 ADS 设计专家...

课程网址: <http://www.edatop.com/peixun/ads/13.html>



### 我们的课程优势:

- ※ 成立于 2004 年,10 多年丰富的行业经验,
- ※ 一直致力并专注于微波射频和天线设计工程师的培养,更了解该行业对人才的要求
- ※ 经验丰富的一线资深工程师讲授,结合实际工程案例,直观、实用、易学

### 联系我们:

- ※ 易迪拓培训官网: <http://www.edatop.com>
- ※ 微波 EDA 网: <http://www.mweda.com>
- ※ 官方淘宝店: <http://shop36920890.taobao.com>