

# PTR5518

## *Coin-size Ultra Low Power Bluetooth 4.0 Low Energy RF Module*

### Features

- Complete Bluetooth low energy solution (Bluetooth 4.0), single mode compliant, Integrated Bluetooth low energy stack/profiles.
- 2.4 GHz transceiver
  - -93 dBm sensitivity in Bluetooth® low energy mode, -96 dBm sensitivity@250kbps,
  - TX Power -20 to +4 dBm in 4 dB steps
  - 13 mA peak RX, 10.5 mA peak TX (0 dBm)
  - RSSI (1 dB resolution)
- ARM® Cortex™-M0 32 bit processor, 256 kB flash memory, 16 kB RAM.
  - 275 µA/MHz running from flash memory
  - 150 µA/MHz running from RAM
  - Serial Wire Debug (SWD)
- Ultra low current consumption , Flexible Power Management
  - Supply voltage range 1.8 V to 3.6 V
  - 2.5 µs wake-up using 16 MHz RCOSC
  - 0.4 µA @ 3 V OFF mode
  - 0.5 µA @ 3 V in OFF mode + 1 region RAM retention
  - 2.3 µA @ 3 V ON mode, all blocks IDLE
- Flexible real-time counter and Two 16 bit and one 24 bit timers with counter mode
- AES Coprocessor, Random Number Generator ,Watchdog Timer ,Temperature sensor
- Rich set of Peripheral: ADC, SPI, 2-wire , and UART. Programmable Peripheral Interconnect(PPI)
- Internal RC Oscillator 32.768 kHz(± 250 ppm).
- Configurable I/O mapping (I/O signals can use any pin, Simple layout of external application)
- Ultra small size(smaller than CR2032 coin battery), about 15mmx15mmx2.5mm with Antenna.

## Typical Applications:

- - 2.4 GHz Bluetooth low energy systems
- - Proprietary 2.4 GHz systems
- - Sports and leisure equipment
- - Mobile phone accessories
- - Health Care and Medical
- - Consumer Electronics, Game pads
- - Human Interface Devices, Remote control
- - Building environment control / monitoring
- - RFID, Security Applications

## Pin Description of Module (Top View) :

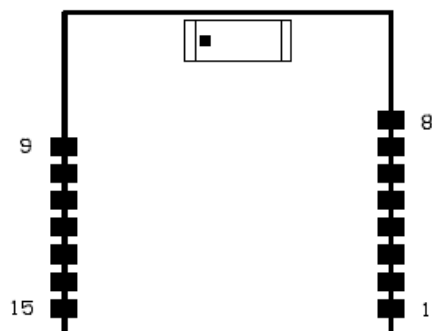

Pin No.	Name	Description	Note
1	P0.08	I/O	
2	P0.09	I/O	
3	P0.12	I/O	
4	SWDIO	Debug and flash programming I/O	
5	SWCLK	Debug and flash programming I/O	
6	P0.17	I/O	
7	P0.18	I/O	
8	P0.19	I/O	
9	GND	Power Ground	
10	VDD	Power Suply (1.9~3.6V)	
11	P0.25	I/O	
12	P0.26	I/O	ADC IN 0
13	P0.27	I/O	ADC IN 1
14	P0.28	I/O	
15	P0.29	I/O	

## Block diagram:

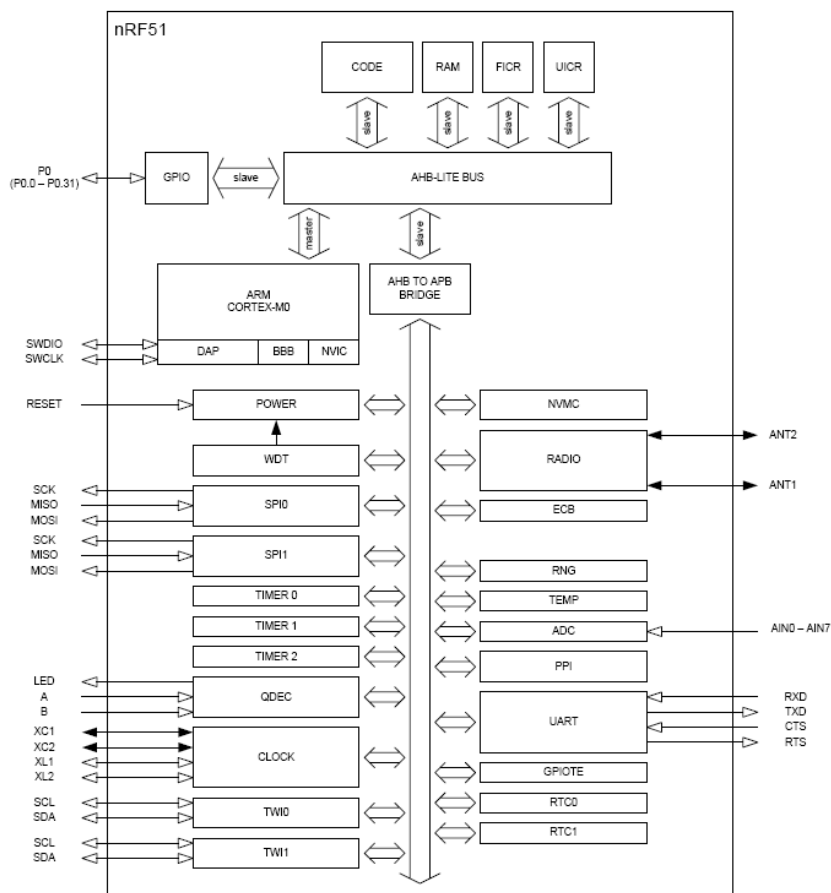

## HW debug and flash programming of Module :

Pin	Flash Program interface
SWDIO	Debug and flash programming I/O
SWCLK	Debug and flash programming I/O

This is the hardware debug and flash programming of module, J-Link Lite support, please refer [www.segger.com](http://www.segger.com).

## Performance Data:

### Transmitter specification:

Symbol	Description	Min.	Typ.	Max.	Units	Test level
P <sub>RF</sub>	Maximum output power		4		dBm	4
P <sub>RFC</sub>	RF power control range	20	24		dB	2
PRFCR	RF power accuracy			±4	dB	1

### Receiver specification:

Symbol	Description	Min.	Typ.	Max.	Units	Test level
<b>Receiver operation</b>						
PRX <sub>MAX</sub>	Maximum received signal strength at < 0.1% PER		0		dBm	1
PRX <sub>SENS,2M</sub>	Sensitivity (0.1% BER) @ 2 Mbps		-85		dBm	2
PRX <sub>SENS,1M</sub>	Sensitivity (0.1% BER) @ 1 Mbps		-90		dBm	2
PRX <sub>SENS,250k</sub>	Sensitivity (0.1% BER) @ 250 kbps		-96		dBm	2
P <sub>SENS IT</sub> 1 Mbps BLE	Receiver sensitivity: Ideal transmitter		-93		dBm	2
P <sub>SENS DT</sub> 1 Mbps BLE	Receiver sensitivity: Dirty transmitter		-91		dBm	2

### Radio current consumption:

Symbol	Description	Min.	Typ.	Max.	Units	Test level
I <sub>TX,+4dBm</sub>	TX only run current @ P <sub>OUT</sub> = +4 dBm		16		mA	4
I <sub>TX,0dBm</sub>	TX only run current @ P <sub>OUT</sub> = 0 dBm		10.5		mA	4
I <sub>TX,-4dBm</sub>	TX only run current @ P <sub>OUT</sub> = -4 dBm		8		mA	2
I <sub>TX,-8dBm</sub>	TX only run current @ P <sub>OUT</sub> = -8 dBm		7		mA	2
I <sub>TX,-12dBm</sub>	TX only run current @ P <sub>OUT</sub> = -12 dBm		6.5		mA	2
I <sub>TX,-16dBm</sub>	TX only run current @ P <sub>OUT</sub> = -16 dBm		6		mA	2
I <sub>TX,-20dBm</sub>	TX only run current @ P <sub>OUT</sub> = -20 dBm		5.5		mA	2
I <sub>TX,-30dBm</sub>	TX only run current @ P <sub>OUT</sub> = -30 dBm		5.5		mA	2
I <sub>START,TX</sub>	TX startup current <sup>1</sup>		7		mA	1
I <sub>RX</sub>	RX only run current @ 1 Mbps		13		mA	4
I <sub>START,RX</sub>	RX startup current <sup>2</sup>		8.7		mA	1

1. Average current consumption (at 0 dBm TX output power) for TX startup (130 μs), and when changing mode from RX to TX (130 μs).
2. Average current consumption for RX startup (130 μs), and when changing mode from TX to RX (130 μs).

## CPU current consumption:

Symbol	Description	Min.	Typ.	Max.	Units	Test level
$I_{\text{CPU, Flash}}$	Run current @ 16 MHz, Executing code from flash memory		4.4 <sup>1</sup>		mA	2
$I_{\text{CPU, RAM}}$	Run current @ 16 MHz, Executing code from RAM		2.4 <sup>2</sup>		mA	1
$I_{\text{START, CPU}}$	CPU startup current		600		$\mu\text{A}$	1
$t_{\text{START, CPU}}$	IDLE to CPU execute	0	3		$\mu\text{s}$	1

1. Includes CPU, flash, 1V2, 1V7, RC16M
2. Includes CPU, RAM, 1V2, RC16M
3.  $t_{1V2}$  if 1V2 regulator is not running already

## Power management:

Symbol	Description	Note	Min.	Typ.	Max.	Units	Test level
$I_{\text{OFF}}$	Current in SYSTEM-OFF, no RAM retention			420		nA	1
$I_{\text{OFF, 16 k}}$	Current in SYSTEM-OFF mode 16 kB SRAM retention			740		nA	1
$I_{\text{OFF, 8 k}}$	Current in SYSTEM-OFF mode 8 kB SRAM retention			530		nA	1
$I_{\text{OFF2ON}}$	OFF to CPU execute transition current			400		$\mu\text{A}$	1
$t_{\text{OFF2ON}}$	OFF to CPU execute			9.6	10.6	$\mu\text{s}$	1
$I_{\text{ON}}$	SYSTEM-ON base current			2.3		$\mu\text{A}$	2

**For more detail information, please refer nRF51822 datasheet.**

PCB Layout (TOP VIEW) :

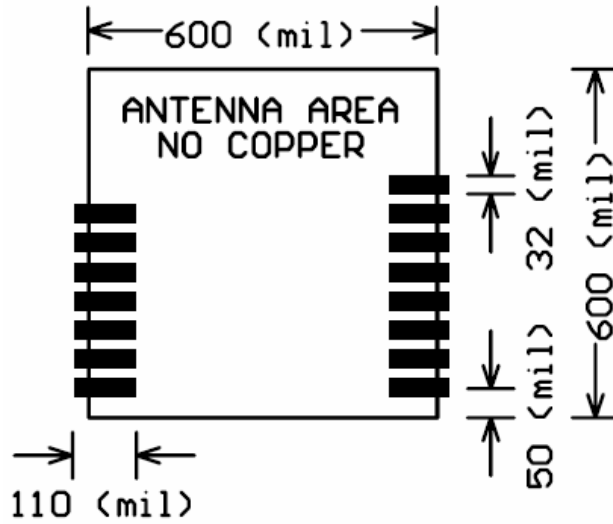

unit: mil

**Important Notice:**

- Reserves the right to make corrections, modifications, and/or improvements to the product and/or its specifications at any time without notice.
- Assumes no liability for the user's product and/or applications.
- Products are not authorized for use in safety-critical applications, including but not limited to life-support applications.

**ATTENTION!**

Electrostatic Sensitive Device  
Observe Precaution for handling.

