

83080 Receiver Architectures and Synchronization  
in Digital Communications

# Practical RF Architectures for GSM and WCDMA Mobile Terminals

# Mobile Generations

- 1st generation systems, analog
  - NMT, AMPS, TACS
- 2nd generation systems, digital
  - GSM, IS-136 TDMA, IS-95 CDMA, PDC
- 3rd generation systems, digital wide band
  - WCDMA standards have been prepared by ETSI (Europe), ARIB (Japan), TTA (USA),...
  - 3GPP<sup>1</sup> is a joint project that combines all proposals into one standard
  - Harmonized standard includes three modes
    - Direct sequence mode based on 3GPP (UTRA<sup>2</sup>/FDD)
    - Multi carrier mode based on CDMA2000 (USA proposal)
    - TDD mode based on 3GPP (UTRA/TDD)

1) 3GPP = 3rd Generation Partnership Project

2) UTRA = Universal Terrestrial Radio Access

# Main Drivers for RF Architecture Design

- Cost, Size, Power consumption
- System complexity, time to market

Component count in GSM RF

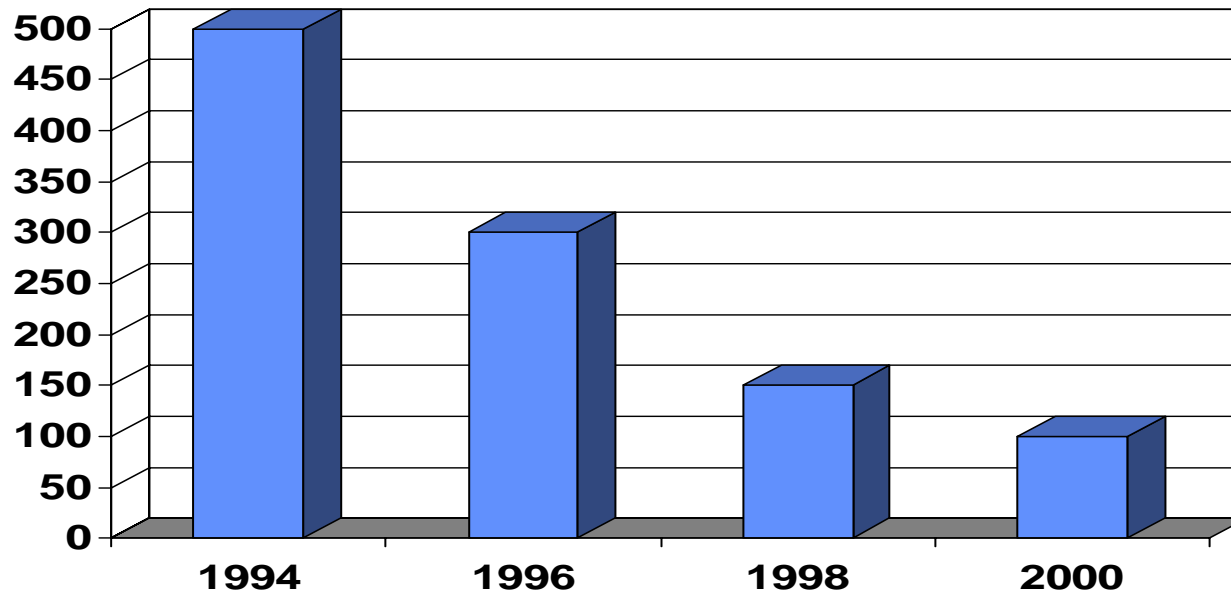

# Design Process - time to market

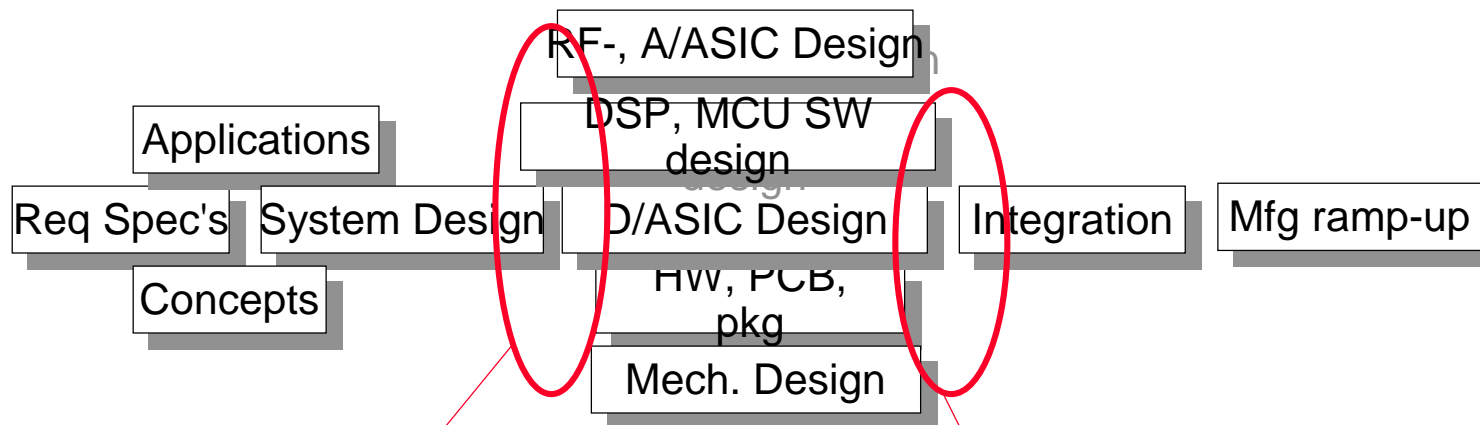

Critical Interface:  
from system design to  
detailed design

Critical Interface:  
from detailed design  
to integration

# GSM Specifications for Receiver

- Bad frame indication performance
- Sensitivity
- Usable receiver input level range
- Co - channel rejection
- Adjacent channel rejection (selectivity)
- Intermodulation rejection
- Blocking and spurious response
- AM suppression

# Example of sensitivity specification

Table 1: Reference sensitivity performance

GSM 900						
Type of channel		Propagation conditions				
		static	TU50	TU50	RA250	HT100
			(no FH)	(ideal FH)	(no FH)	(no FH)
FACCH/H	(FER)	0.1 %	6.9 %	6.9 %	5.7 %	10.0 %
FACCH/F	(FER)	0.1 %	8.0 %	3.8 %	3.4 %	6.3 %
SDCCH	(FER)	0.1 %	13 %	8 %	8 %	12 %
RACH	(FER)	0.5 %	13 %	13 %	12 %	13 %
SCH	(FER)	1 %	16 %	16 %	15 %	16 %
TCH/F9.6 & H4.8	(BER)	10 <sup>-5</sup>	0.5 %	0.4 %	0.1 %	0.7 %
TCH/F4.8	(BER)	-	10 <sup>-4</sup>	10 <sup>-4</sup>	10 <sup>-4</sup>	10 <sup>-4</sup>
TCH/F2.4	(BER)	-	2 10 <sup>-4</sup>	10 <sup>-5</sup>	10 <sup>-5</sup>	10 <sup>-5</sup>
TCH/H2.4	(BER)	-	10 <sup>-4</sup>	10 <sup>-4</sup>	10 <sup>-4</sup>	10 <sup>-4</sup>
TCH/FS	(FER)	0.1 $\alpha$ %	6 $\alpha$ %	3 $\alpha$ %	2 $\alpha$ %	7 $\alpha$ %
	class Ib (RBER)	0.4/ $\alpha$ %	0.4/ $\alpha$ %	0.3/ $\alpha$ %	0.2/ $\alpha$ %	0.5/ $\alpha$ %
	class II (RBER)	2 %	8 %	8 %	7 %	9 %
TCH/HS	(FER)	0.025 %	4.1 %	4.1 %	4.1 %	4.5 %
	class Ib (RBER, BFI=0)	0.001 %	0.36 %	0.36 %	0.28 %	0.56 %
	class II (RBER, BFI=0)	0.72 %	6.9 %	6.9 %	6.8 %	7.6 %
	(UFR)	0.048 %	5.6 %	5.6 %	5.0 %	7.5 %
	class Ib (RBER,(BFI or UFI)=0)	0.001 %	0.24 %	0.24 %	0.21 %	0.32 %
	(EVSIDR)	0.06 %	6.8 %	6.8 %	6.0 %	9.2 %
	(RBER, SID=2 and (BFI or UFI)=0)	0.001 %	0.01 %	0.01 %	0.01 %	0.02 %
	(ESIDR)	0.01 %	3.0 %	3.0 %	3.2 %	3.4 %
	(RBER, SID=1 or SID=2)	0.003 %	0.3 %	0.3 %	0.21 %	0.42 %

# How to convert system specifications to RF design parameters ?

- From the bit error rate (BER) requirement of the whole phone we can derive secondary specifications for the radio section (Gain, Signal to Noise ratio, Linearity)
- System specification and detector implementation define the required S/N ratio
- GSM needs 8...9 dB S/N (number includes some implementation margin 2...3 dB)

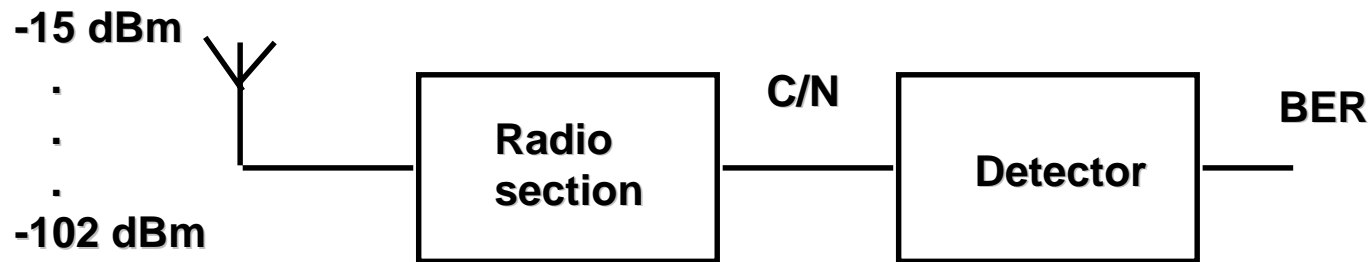

# Sensitivity

Signal must be 9 dB above noise floor, so requirement for receiver noise figure (NF) is

$$NF = P_s + 174 \text{ dBm} - 10 \log B - S/N$$

where

$B$  is equivalent noise bandwidth of the receiver

$P_s$  is reference sensitivity level

For GSM 900 MHz  $P_s = -102 \text{ dBm} \rightarrow NF = 10 \text{ dB}$

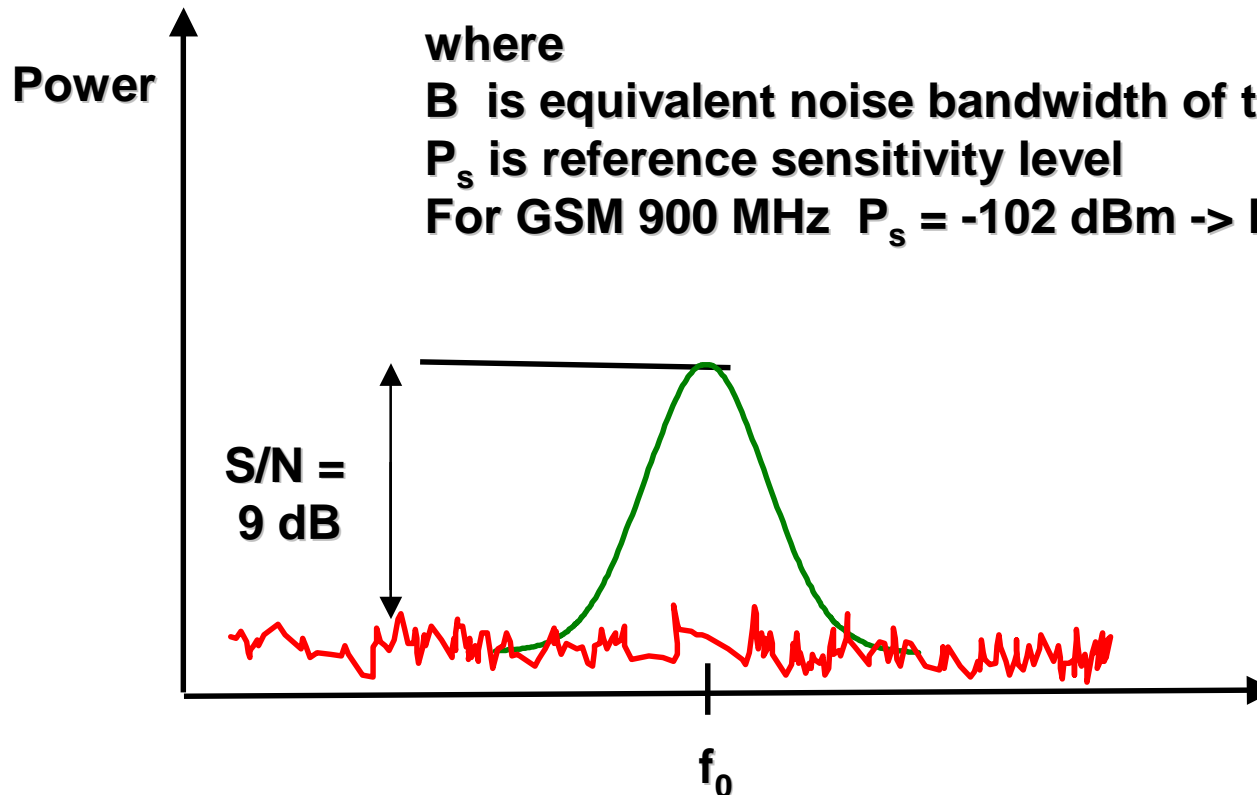



# Sensitivity and Selectivity

- Cascaded noise figure
  - $NF = 10 \log F$ , where NF is noise figure and F is noise factor
  - $F = F_1 + (F_2 - 1)/G_1 + (F_3 - 1)/G_1 G_2 + \dots + (F_n - 1)/G_1 G_2 \dots G_{n-1}$
- RF section must have enough gain to provide adequate signal level for A/D converter
- Minimum input level is -102 dBm  $\rightarrow$  1.8  $\mu$ V @ 50 ohm. If we need for example 100 mV at A/D converter input, voltage gain needs to be  $20 \log(100\text{mV}/1.8\mu\text{V}) = 95$  dB

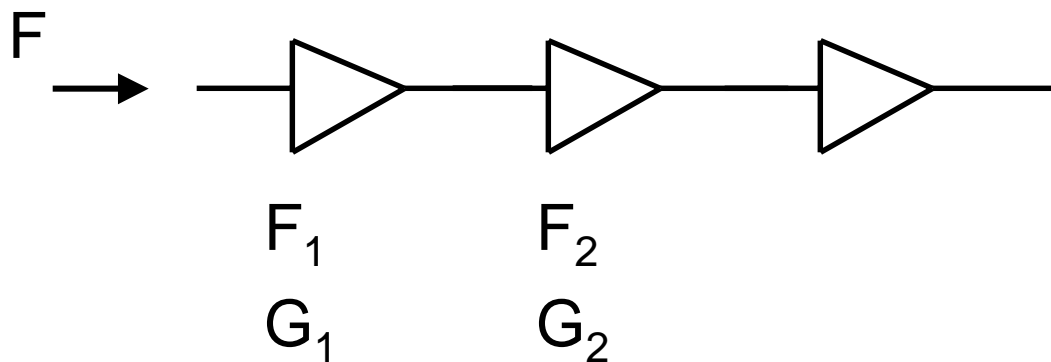

# Selectivity

- Before detector interfering signals need to be filtered so that S/N is adequate
- This attenuation is split between IF filter, analog BB filter and digital filter after A/D
- Digital filtering at baseband would be cost effective but then A/D converter must be able to handle wider dynamic range (typical A/D resolution 10...12 bits)
- Distribution of gain and selectivity affects also linearity requirement of the analog part
- If interfering signal is for example  $-43 \text{ dBm} \rightarrow 5 \text{ mV @ } 50 \text{ ohm}$  and we amplify that  $95 \text{ dB}$  the signal level would be  $280 \text{ V} !$



Microsoft Excel  
Worksheet

# Phase Noise

- Local oscillator (LO) phase noise has effect both on sensitivity and selectivity
- Phase noise may pass through mixer and degrade sensitivity different ways
  - 1) Noise at IF leaks directly into mixer IF port
  - 2) Noise at RF leaks directly into mixer RF port
  - 3) Noise at the distance of IF from the RX-frequency mixes with RX and appears in the mixer IF port
  - 4) Noise at the distance of IF from the LO-frequency mixes with LO and appears in the mixer IF port

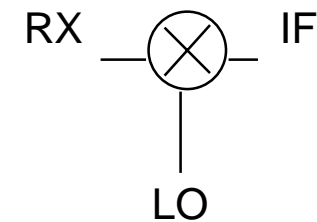
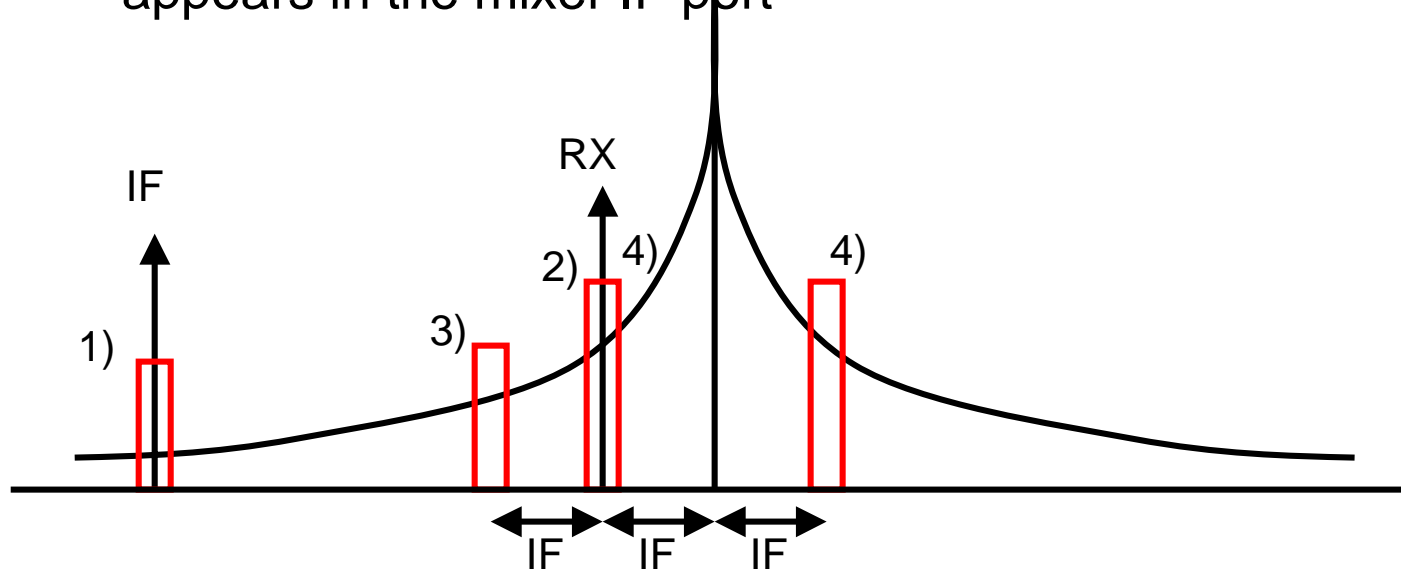

# Phase noise

- LO mixes both with wanted signal and interfering signal
- LO spectrum shifts to IF

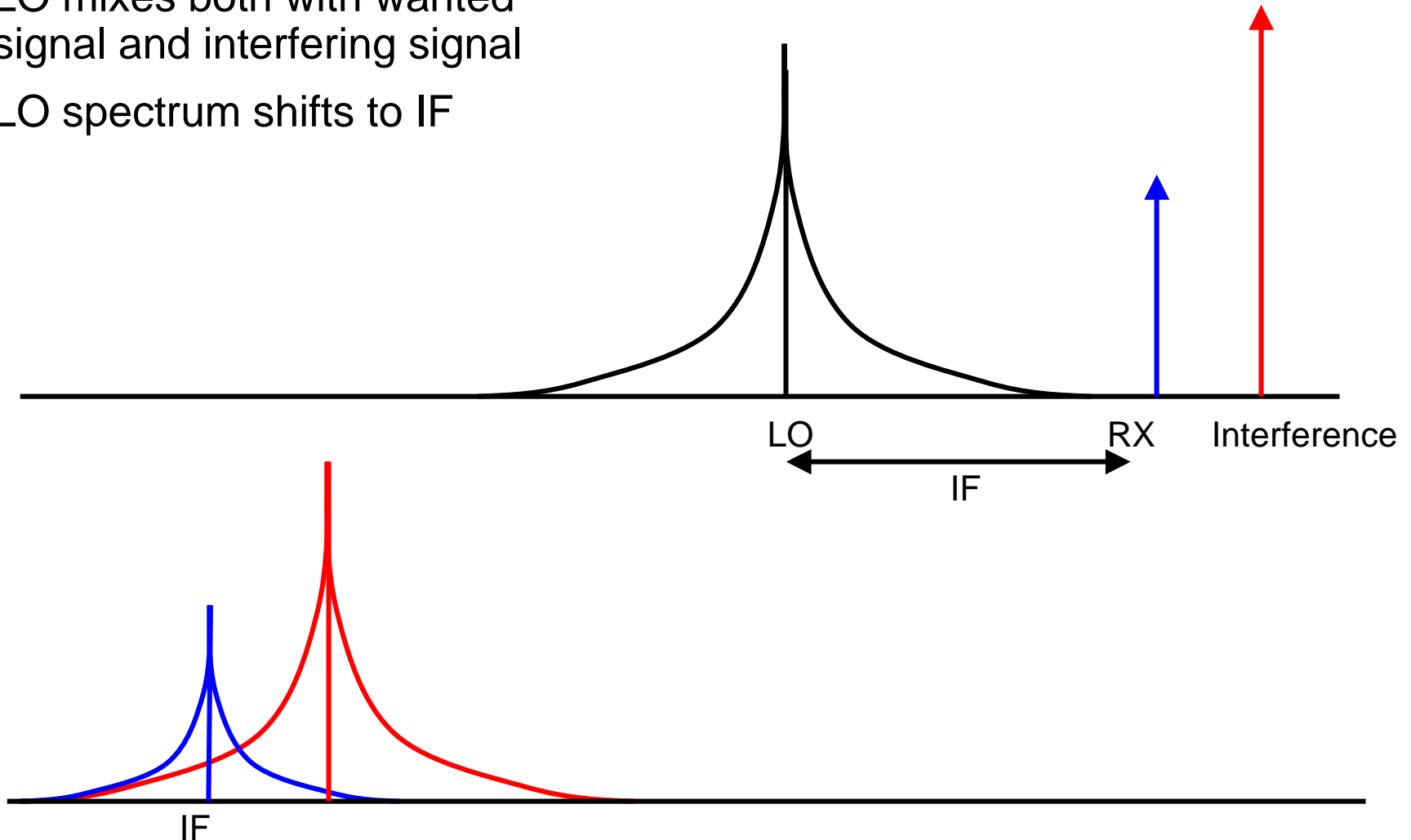

# Phase noise

- Usually selectivity sets most difficult requirement for VCO phase noise
- Example GSM 900 MHz handportable:
  - wanted signal  $-102 \text{ dBm} + 3 \text{ dB} = -99 \text{ dBm}$
  - blocking signal  $-43 \text{ dBm}$  @ 600 kHz offset
  - typical values  $S/N = 9 \text{ dB}$ , noise BW = 200 kHz
  - Phase noise =  $-99 - (-43) - 10 \log 200000 - 9 = -118 \text{ dBc/Hz}$  (600 kHz)

# Receiver Architectures

- Heterodyne
  - + flexibility, achievable component specifications
  - + standard components available
  - spurious responses
- IF Sampling
  - + no need for I/Q mixer
  - requires better A/D converter
- Homodyne (direct conversion)
  - + simplest architecture
  - + no IF filters, advantage especially in multiband/multisystem phones
  - very difficult to implement

# GSM Receiver Principles

- GMSK modulation has no AM component that carries information
- However the equalizer requires real time amplitude information to be able to correct the multipath propagation
- Most common solution is linear receiver that provides in-phase (I) and quadrature (Q) signals for the baseband
- Non linear (limiting) receiver possible, if it can provide amplitude information for the equalizer

# Limiting Receiver in GSM

- Relaxes AGC and A/D requirements
- High level interferers must be low enough before limiter -> requires good IF filters
- Can handle fast amplitude changes without saturation



# Spurious response rejection

- Mixing products in nonlinear circuits can cause spurious responses if they fall at IF or RX frequency
- Usually low order products are the most important
- Some examples of spurious responses in superheterodyne receiver with high side LO injection

Image:  $f_{\text{SPUR}} - f_{\text{LO}} = f_{\text{IF}}$

Half IF:  $2f_{\text{LO}} - 2f_{\text{SPUR}} = f_{\text{IF}}$

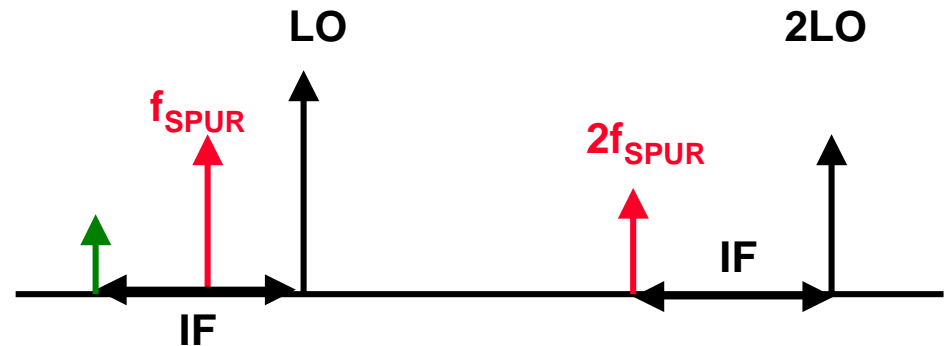
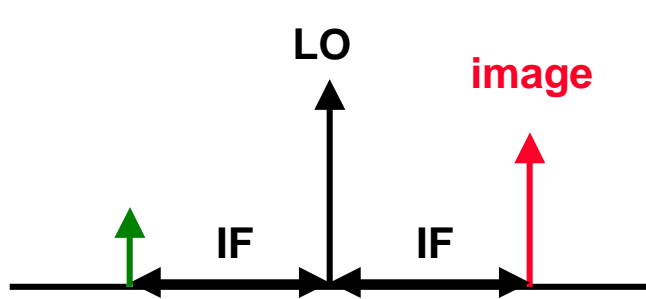

# Spurious response rejection

- In full duplex systems the high level TX signal causes more spurious responses
- If TX leaks to RX mixer it mixes directly with spurious signal:  $f_{\text{SPUR}} - f_{\text{TX}} = f_{\text{IF}}$
- Mixing can also take place in power amplifier:  $2f_{\text{TX}} - f_{\text{SPUR}} = f_{\text{RX}}$

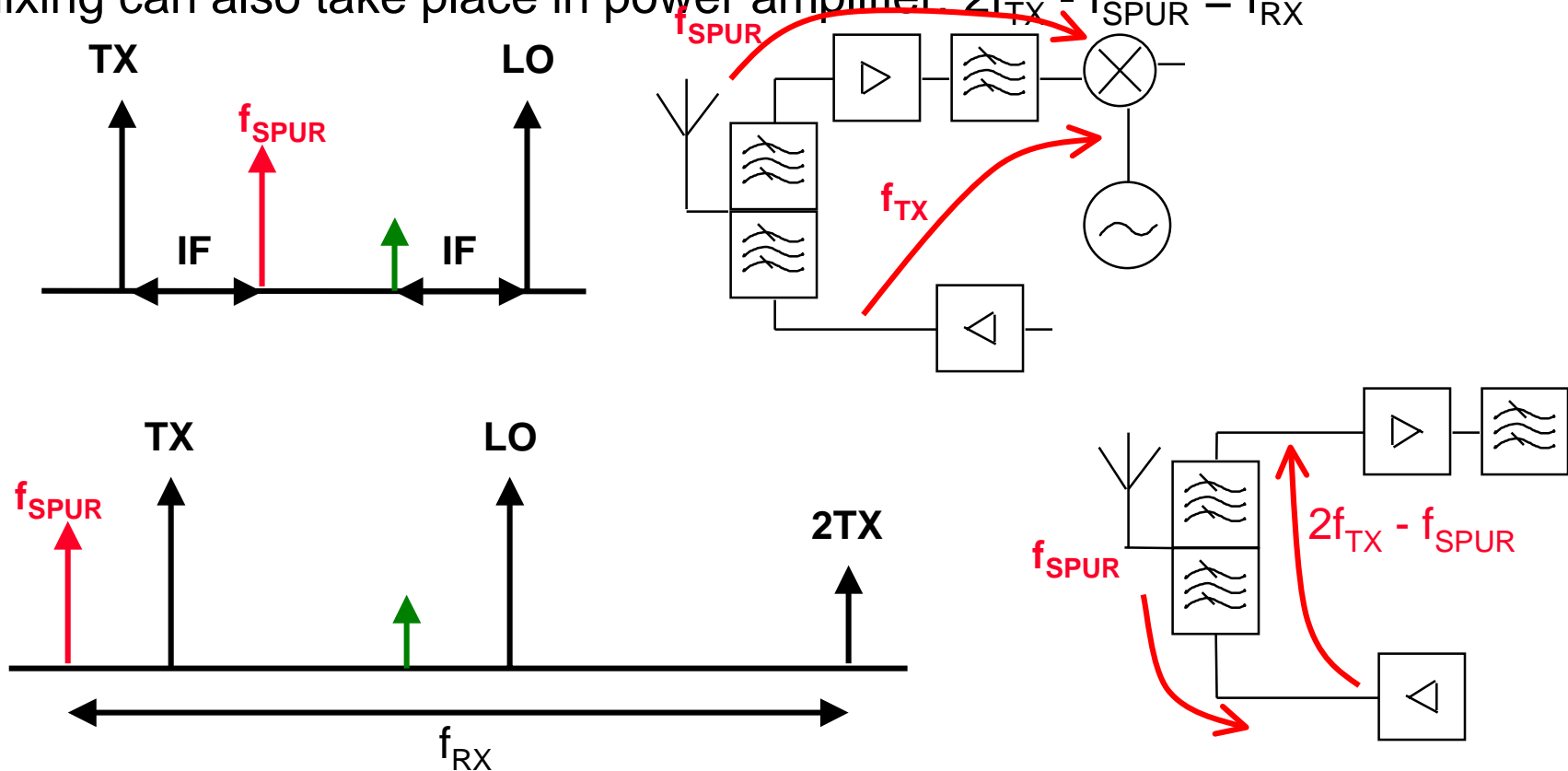

# Choosing IF frequency

- Spurious response requirements
  - Image should be at relatively quiet band
  - Usually  $IF/2$  spurious should not be in RX band  $\rightarrow$  first  $IF > 2 * \text{operating band}$
  - $TX + IF$  should not fall in RX band (on the other hand we can use  $TX + IF = RX$ )
- IF filter availability, size and cost
  - 71 MHz is most popular GSM IF at the moment
  - Higher frequency SAW filter is smaller but stopband attenuation is not as good
- LO frequency
  - lower frequency is slightly easier to implement. On the other hand in mobile TX band is below RX and LO may be too close to TX band with low side injection
- Amount of oscillators
  - Use same oscillator for RX and TX if possible
  - harmonics of the oscillators should not fall in RX band

# Duplexing Techniques

- Uplink and downlink signals can be separated using different frequency or different time slot
- RX and TX use same frequency but different time slot
- -> Time Division Duplex (TDD)
- RX and TX are on simultaneously but use different frequency
- -> Frequency Division Duplex (FDD)
- GSM can use either switch or duplexer
- WCDMA must use a duplexer (option for TDD in the spec.)

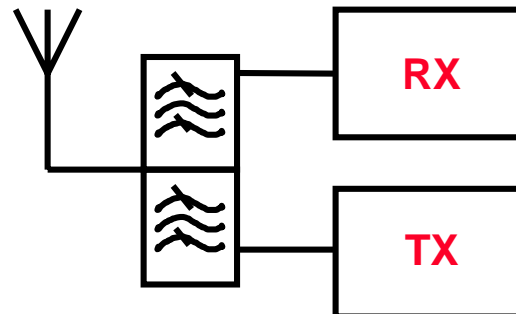
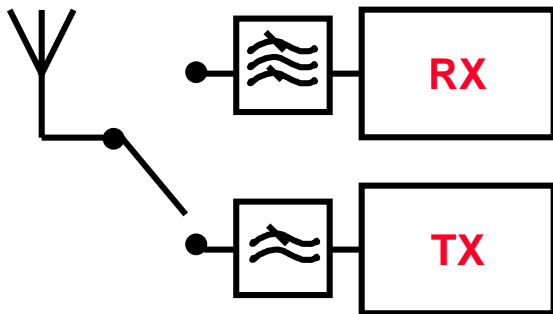

# Duplexing Issues

- Using a duplex filter in GSM may be feasible if RF architecture is such that also TX needs good filtering
- If a simple high pass filter is adequate in TX, lower cost and size can be achieved with a switch and separate filters
- Typically switch and filters are combined in a ceramic module
- In GSM system receive and transmit functions occur in different time slots
  - Isolation between TX and RX is not a concern
    - High level circuit integration possible
    - Common blocks for RX and TX possible, e.g. synthesizer (frequency can be shifted between RX and TX time slots)
    - Less spurious responses in the RX

# Automatic Gain Control (AGC)

- With AGC the average signal level at the A/D converter input is kept almost constant
  - Trade off between AGC and A/D converter dynamic range
- In GSM phone reports received signal strength and  $\pm 1$  dB relative measurement accuracy is required from -110 dBm to -48 dBm
- In IS-95 CDMA the TX power must follow received signal strength:  $P_{out} = -P_{in} - 76$  dBm at the input range -104 dBm to -25 dBm (open loop power control, accuracy requirement  $\pm 9.5$  dB)
- In CDMA RX and TX gain controls should have similar temperature behavior

# AGC Implementation

- Accuracy and temperature compensation are easier to implement at IF and baseband
- By adjusting front-end gain, AGC also provides a measure against intermodulation distortion at high signal levels
- Often AGC is split between front-end and IF, for example 20...30 dB step in front-end and 60...80 dB at IF

# Example of a GSM Block Diagram

## Superheterodyne with IF sampling GSM 900 MHz

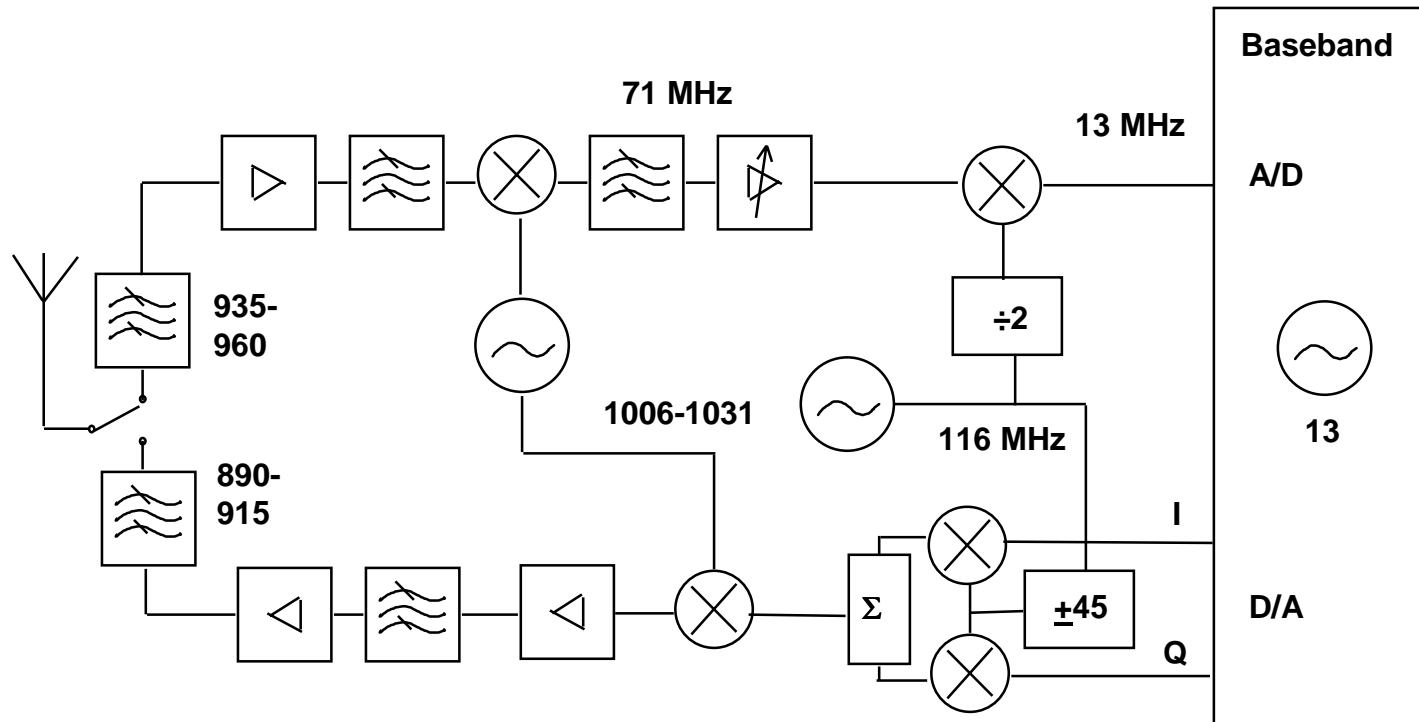



# Example of a GSM Block Diagram

## Superheterodyne GSM 900 MHz

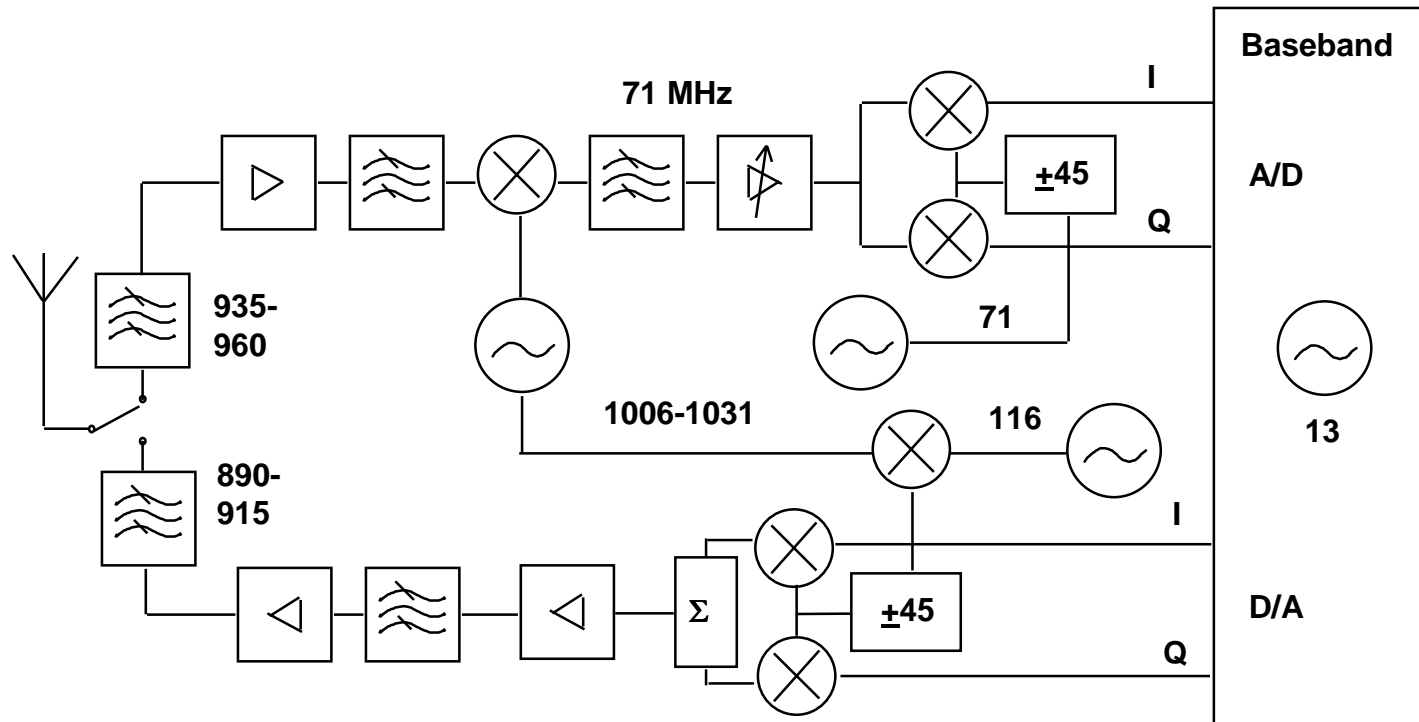

# Example of a GSM Block Diagram

Direct conversion GSM 900 MHz

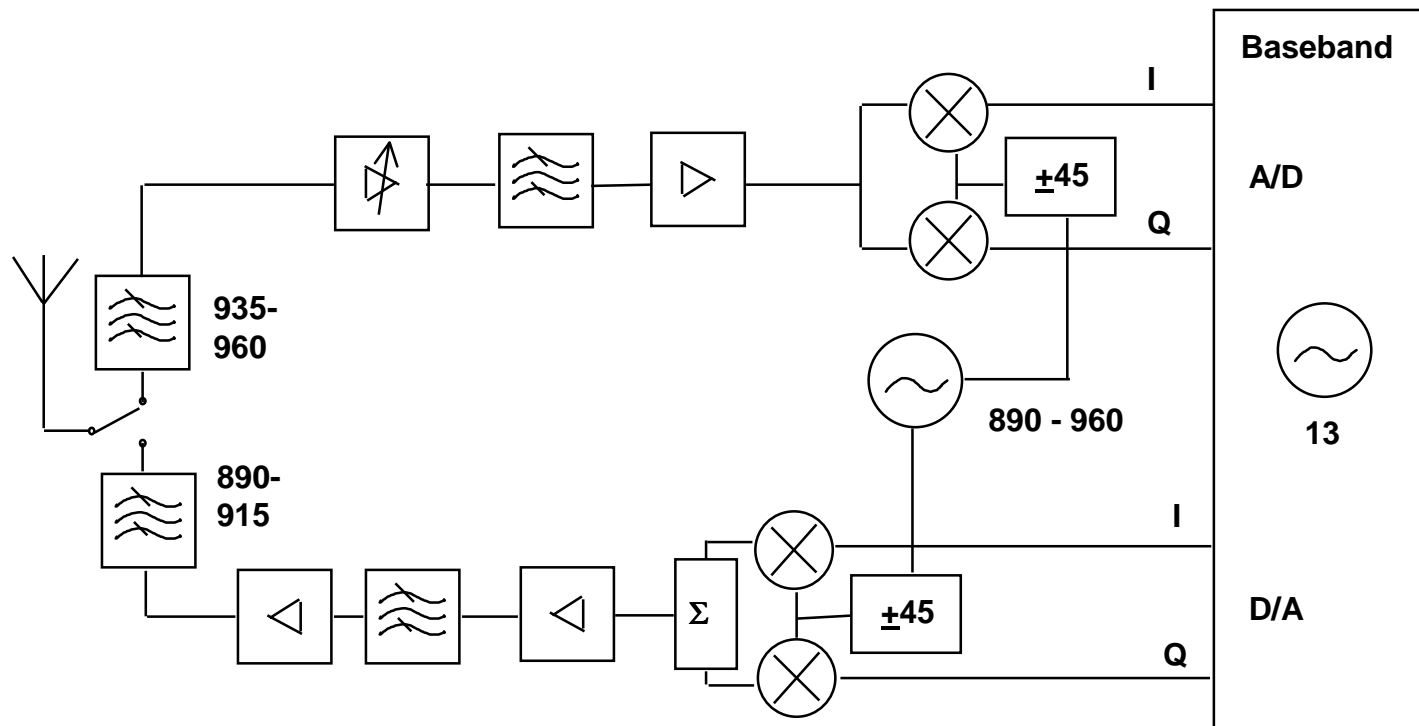

# Direct Conversion Implementation

- LO leakage to the RX input causes DC-offset
- LO leakage can not be filtered out and it may cause too high spurious emissions (limit in GSM specification is -57 dBm)
- High level interference signals can couple to LO and cause LO pulling
- RF part must be very linear because strong adjacent channel signals are not filtered out until baseband
- To meet all requirements mixer linearity and balance are essential

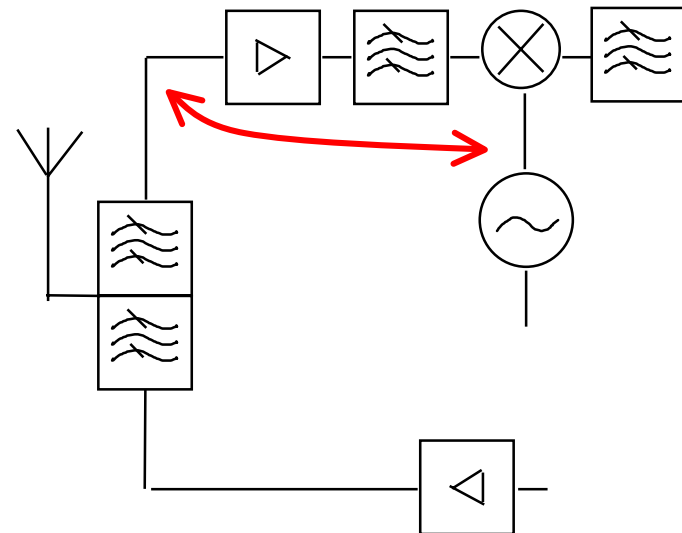

# Direct Conversion Implementation

- Can be much larger than a weak signal
- DC offset is first measured without signal before RX burst
- This information is then used to cancel offset just before detection
  
- Direct conversion implemented in GSM by Alcatel and Nokia
- RFIC vendors are developing direct conversion chipsets (Analog Devices)

# Direct Conversion Implementation

- Balanced circuits and double LO frequency reduce interference coupling

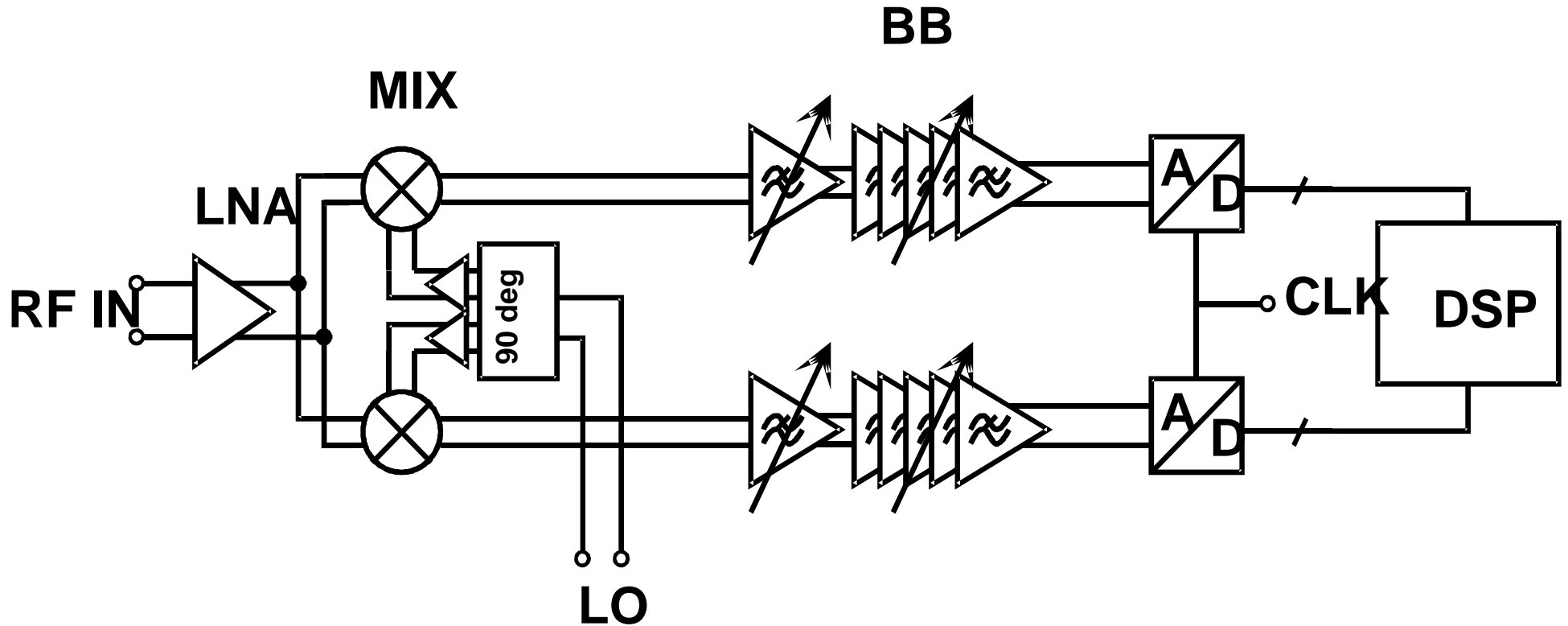

# GSM Data Services, HSCSD and GPRS

- HSCSD & GPRS
  - HSCSD = High Speed Circuit Switched Data
  - GPRS = General Packet Radio Service
  - Different coding 9.6 kbit/s -> 14.4 kbit/s
  - More slots, for example 2 slots -> 28.8 kbit/s
  - Dynamic use of slots in GPRS
  - In multislots case receiver has less time to change channel -> synthesizer must be faster
  - Adjacent slots may have different amplitude -> more dynamic range needed because gain control has no time to adapt

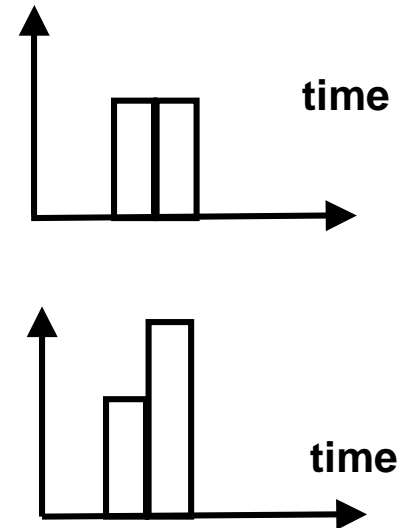

# GSM Data Services, EDGE

- In EDGE also modulation changes GMSK -> 8PSK
- Not constant amplitude anymore, only linear receiver possible
- EDGE has several coding schemes and fastest data speeds can only be achieved with very good signal to noise conditions
- Theoretical maximum 69 kbit/s per timeslot
- AGC gain distribution important
  - LNA gain step should not be used as low levels as in basic GSM

# GSM Radio Access in the Time Domain

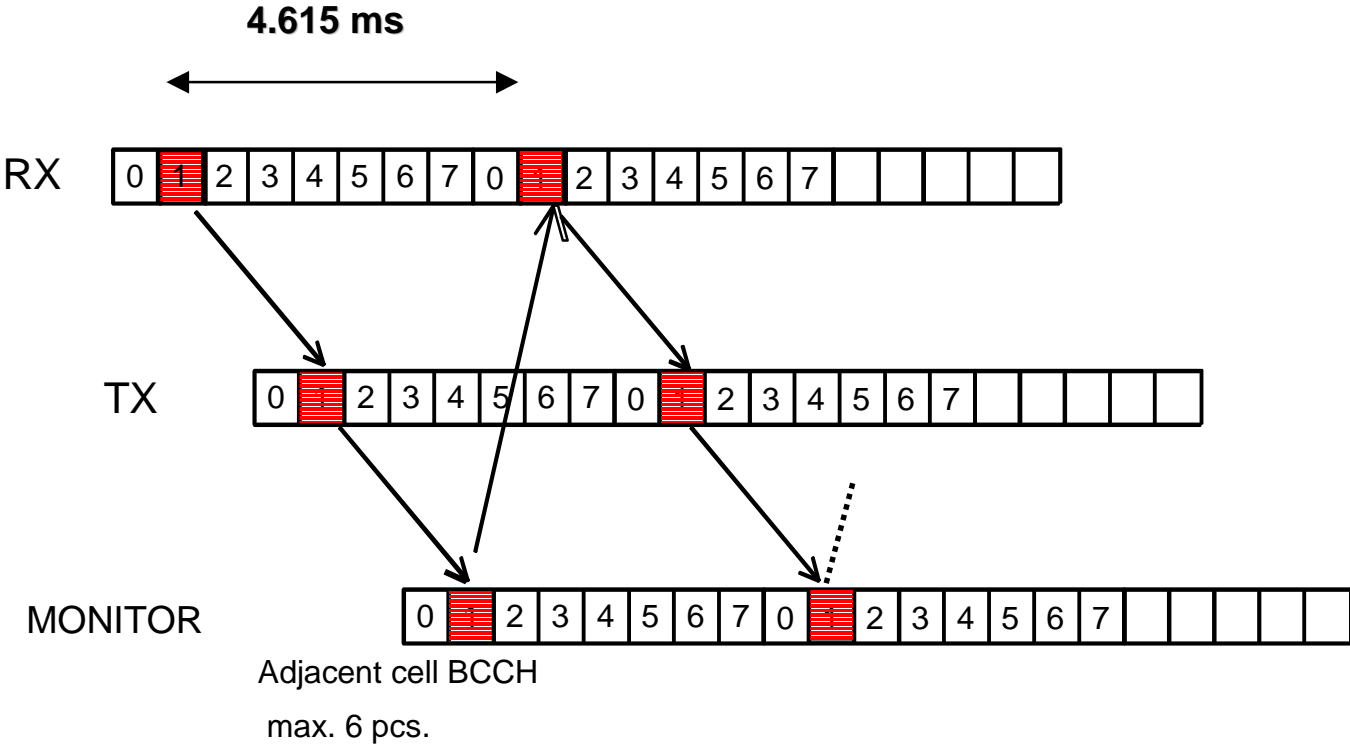



# HSCSD RF

- 2 + 2 slots or 3 +1 slots still leave some settling time between the slots
- In dual slot operation with maximum timing advance the time between RX and TX slots is  $577 \mu\text{s} - 233 \mu\text{s} = 344 \mu\text{s}$
- It becomes difficult to achieve this with conventional synthesizer
  - Separate synthesizers for RX and TX
  - Fractional-N synthesizer
  - Use double frequency (synthesizer step 400kHz) and divide for LO
- 3 + 3 slots and higher the RX and TX overlap and whole RF system design must be different including two synthesizers, duplex filter and high isolation between TX and RX

# Spread-Spectrum Basics

- Spectrum is spread using a code that is independent of the information signal
- Bandwidth used in spread spectrum transmission is typically at least 100 times wider than the information signal bandwidth
- WCDMA uses direct sequence spreading where a pseudo-random code is directly combined to the signal
- Users are separated by different codes
- Bits in the spreading code are called chips

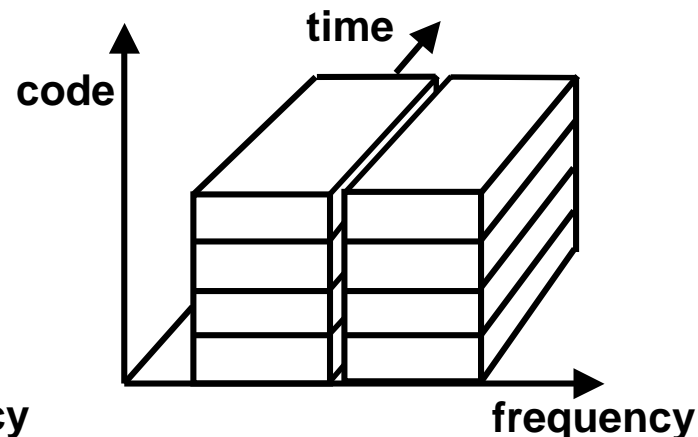
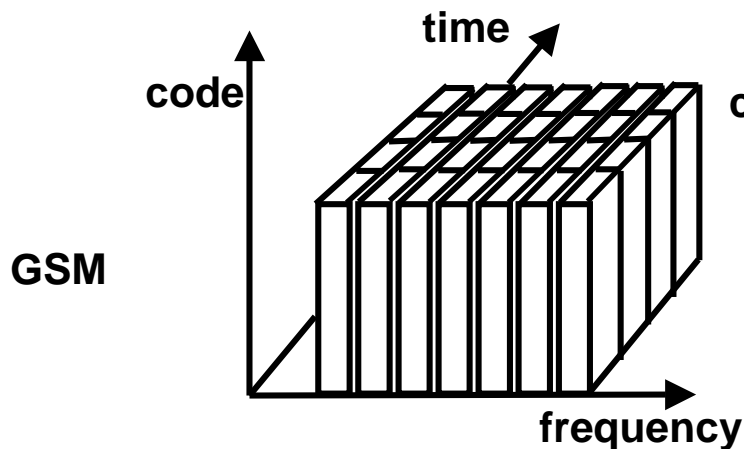

# Mobile Radio Channel

Multipath propagation (frequency selective fading)

Shadowing

Doppler shift

linear time-variant channel

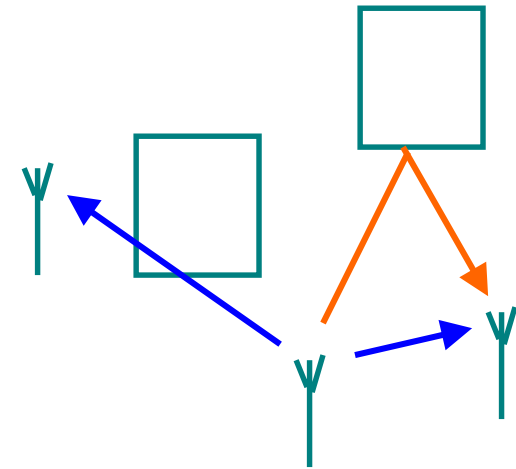
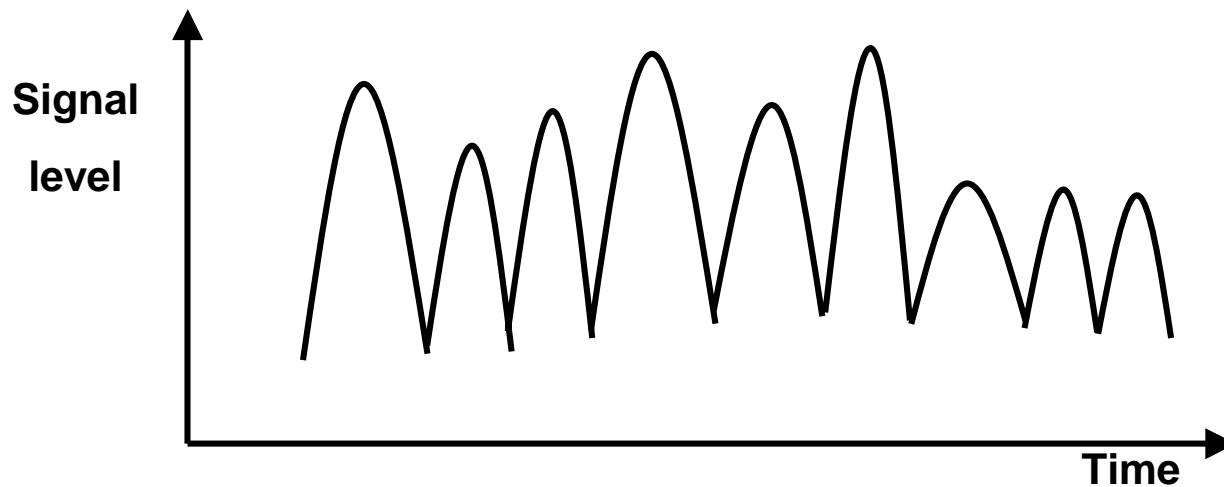

# Mobile Receiver

- In GSM training sequence is used to estimate the impulse response of the radio channel
- This information is necessary to equalize the user bits on a burst by burst basis
- CDMA chip rate is typically greater than flat fading BW of the channel and multipath components appear like uncorrelated noise -> no equalizer is needed
- RAKE receiver combines time shifted versions of the original signal
  - One finger is assigned for the direct signal, another for the reflected signal
- Fingers in RAKE receiver can also be used for soft handoff
  - One finger is assigned for new base station while another still listens the old BS
- RAKE receiver is implemented in digital baseband and it does not require any special functionality in RF part -> Receiver can be implemented with similar blocks as current GSM receiver

# CDMA System Parameters

- IS-95 CDMA
  - Frequency bands
    - Cellular band (AMPS): TX 824...849, RX 869...894 MHz
    - PCS1900: TX 1850...1910, RX 1930...1990 MHz
  - Carrier spacing 1.25 MHz, 64 Walsh codes
  - Chip rate 1.2288 Mchip/s
- WCDMA
  - Frequency bands
    - UTRA FDD (Europe & Asia): TX 1920...1980 MHz , RX 2110...2170 MHz
  - Carrier spacing 5.00 MHz
  - Chip rate 3.84 Mchips/s (first proposal 4.096 Mchips/s)

# Receiver requirements

- Sensitivity requirement is -117 dBm @ 12.2 kbps user data rate
- Changing user bit rate changes processing gain (PG) and also sensitivity level
- $PG = 10 \log (3.84\text{Mcps}/\text{user symbol rate})$
- Selectivity requirement is defined as RX filter attenuation at adjacent channel compared to wanted channel, spec is 33 dB, interferer crest factor not defined yet

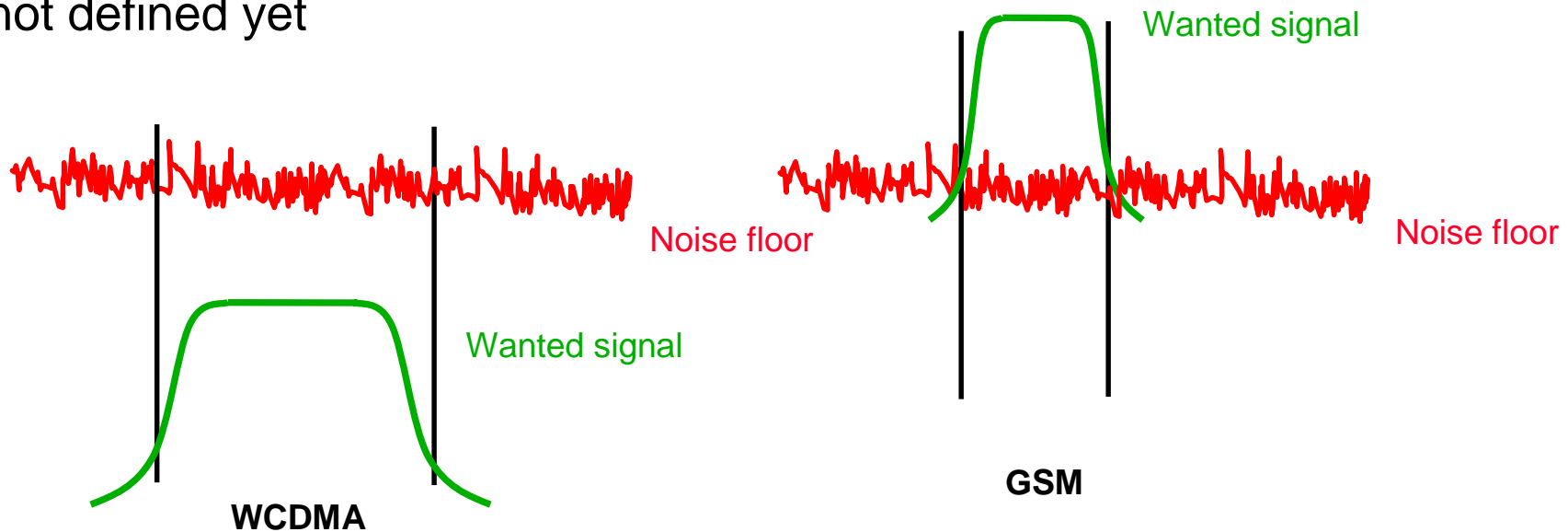

# RX Design issues

- Full duplex operation
  - TX noise at RX band must be attenuated
  - A good duplexer is relatively large and expensive component
- High chiprate
  - Wide BW in baseband -> higher current consumption
  - Wide band IF filters -> higher loss

# WCDMA RX Design Issues

- Linear modulation -> limiting receiver not possible
- In full duplex system TX noise at RX band may desense receiver
  - If we require that TX is not decreasing RX sensitivity, noise at RX input must be below thermal noise floor (-174 dBm/Hz)
  - Even if TX chain is relatively low noise, about 40 dB attenuation is needed in duplexer
- Wider band compared to GSM increases slightly filter losses and current consumption

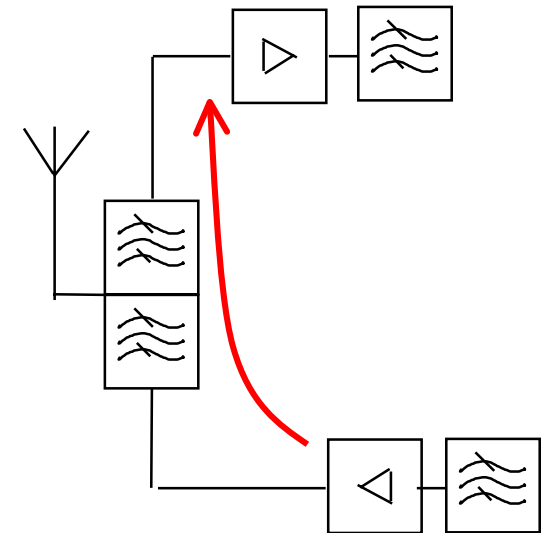



# Variable duplex separation

- In WCDMA specification there is an option to use variable duplex separation
- This means that receiver and transmitter channels can be selected freely and distance between RX and TX center frequency is variable
- In current situation where operators have only two or three channels this option is not useful but if more spectrum becomes available it makes spectrum allocation more flexible
- In superheterodyne receive variable duplex separation increases number of spurious responses dramatically and makes the calculation complex
- With direct conversion architecture independent RX and TX frequencies are relatively easy to implement

# Direct Conversion Receiver in WCDMA

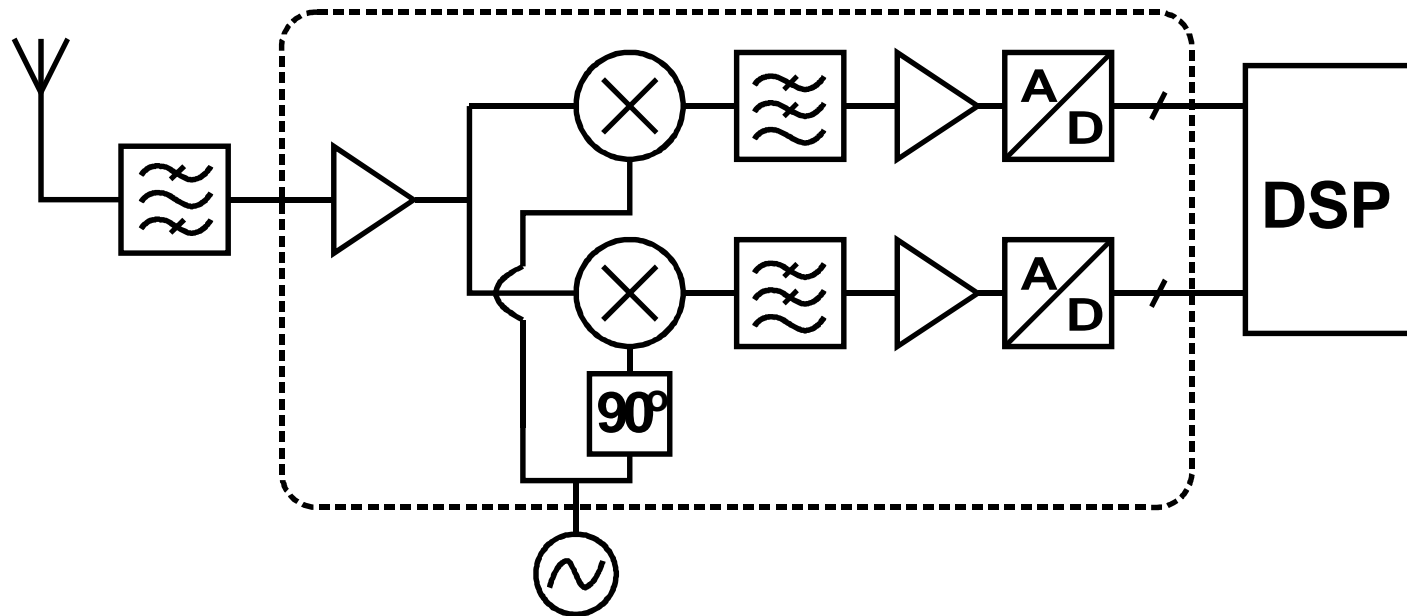

- Integration level
- Image suppression
- DC offsets
- Envelope distortion
- Flicker noise

# Direct conversion problems in CDMA

- No idle time slots for cancellation
- Highpass filtering possible (dc block in the signal path or servo feedback)
  - Slow transients
  - Large component values
- Long-term average subtracted from signal
  - DSP controls analog offset
- Digital methods
  - Typically for offsets 10-50 % depending on algorithm
- Own TX interference
  - Leakage through duplex filter and to RX VCO
  - TX modulation at mixer output
  - Double VCO frequency  $f=4$  GHz and differential circuits reduce coupling

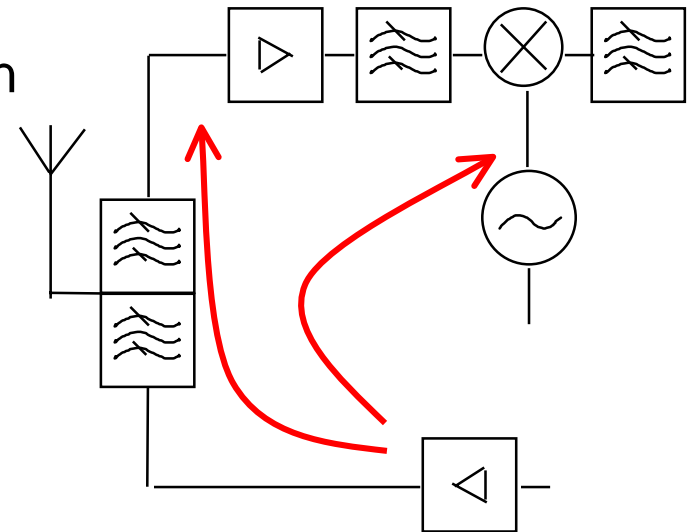

# WCDMA & Direct Conversion

- Envelope distortion
  - 2nd-order nonlinearity
  - BALANCING
  - Mixer and first stages of baseband critical
  - Interference sources: all radio channels containing AM
    - Variable (non-constant) envelope in digital modulation
      - QPSK, QAM
    - TDMA (GSM)
    - TDD (WCDMA)

# WCDMA & Direct Conversion

- Analog baseband processing
  - Mixer is a part of the demodulator
    - I/Q balance
  - Offsets
  - Gain control
    - Time constant critical inside offset compensation loop
    - Techniques to maintain the same offset with different gain values
  - Flicker noise
    - Critical in direct conversion
    - Linearity & power consumption limits gain at RF
    - Smaller relative contribution in wide-band system

# Integrating WCDMA Receiver

- Most functions can already be integrated
- Most difficult blocks are
  - Front end RF filters
  - Tank circuit in VCO
  - Reference oscillator, at least crystal is external
- Small size & smaller parasitics
- Better matching
- Low cost in mass production

# Single-Chip Integration

- High-speed clock and digital signals on the same chip with RX front-end
- Coupling through substrate and interconnections
- Transmitter power and noise on RX band
- Differential RF
- Double VCO frequency

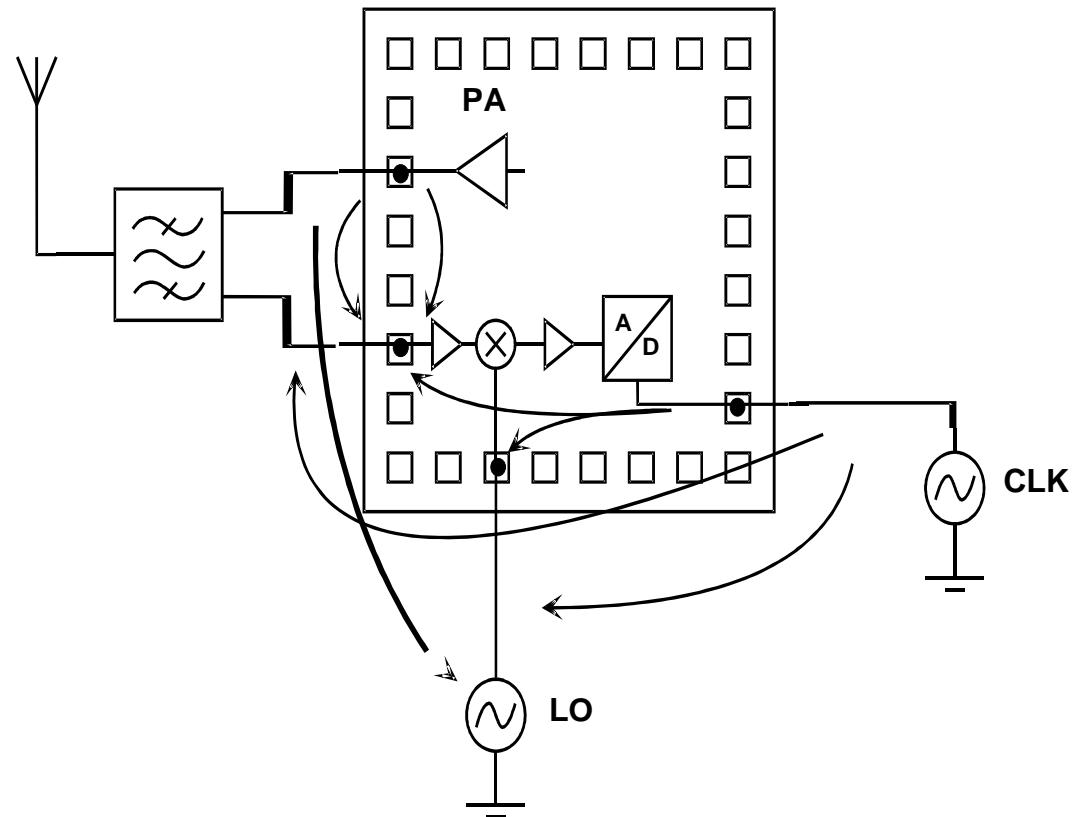

# Component Technologies

- RF part of a GSM phone includes typically following blocks
  - One RF ASIC including RX, synthesizer(s) and TX
  - Power amplifier
  - VCO module
  - TCXO module
  - Front end switch
  - SAW filters (RX front end filter may be on the switch module)
  - Some passive components
- In WCDMA RX and TX are likely to be on separate chips



# Component Technologies, RFIC

- BiCMOS process is most suitable for RF ASIC design
  - Good RF performance
  - Easy to implement control logic and digital part in synthesizer
- SiGe option increases  $f_t$ 
  - Main advantage of higher speed process is lower power consumption
- Packages are typically ball grid arrays (BGA) with pin count up to 100
- Power amplifier technologies
  - HBT GaAs (most popular today)
  - Silicon MOS
  - GaAs FET
  - Silicon bipolar
  - InP and InGaP are promising some performance improvement over GaAs HBT

# Component Technologies, Filters and Switches

- Filter technology has been changing from ceramic to surface acoustic wave (SAW)
- Bulk Acoustic Wave (BAW) filters would give even smaller size and some integration possibilities
- BAW technology is more difficult to implement than SAW because also material thickness should be controlled extremely accurately
- Switches are used in front end so performance is very important because it directly effects the total receiver performance
- GaAs FET and pin diode switches are used today
- Micromechanical Switches (MEMS) would improve both insertion loss and isolation performance dramatically
- MEMS linearity is also superior compared to electrical switches
- Problems today are reliability and high control voltages

# Receiver Components

- Typical IF filter specifications

	<b>900 M H z G S M</b>	<b>800 M H z C D M A</b>	<b>1900 M H z C D M A</b>
<b>C e n t e r f r e q .</b>	<b>71 M H z</b>	<b>85 M H z</b>	<b>210 M H z</b>
<b>B a n d w i d t h</b>	<b>200 k H z</b>	<b>1.25 M H z</b>	<b>1.25 M H z</b>
<b>I n s e r t i o n l o s s</b>	<b>7 d B</b>	<b>12 d B</b>	<b>9 d B</b>
<b>A t t n @ 600 k H z</b>	<b>30 d B</b>		
<b>A t t n @ 900 k H z</b>	<b>35 d B</b>		
<b>A t t n @ 1.25 M H z</b>	<b>33 d B</b>		

# Statistical Analysis

- Because manufacturing volumes are high receiver architecture must be robust and tolerate some component variation
- If daily production is for example 10000 phones and yield is 90% it means that there is 1000 phones to be fixed
- As a rule of thumb most parameters need 2...3 dB marginal. For example if sensitivity limit is -102 dBm, design target should be around -105 dBm
- To avoid unnecessary high margins receiver chain should be analysed with some statistical method (Monte Carlo Analysis)

# Power Consumption

- Power consumption of the amplifiers and mixers depend on the intermodulation requirements
- For example a typical LNA with 18 dB gain and below 2 dB noise figure can be easily designed to take only a few milliwatts of power if there is no IIP3 requirement
- Typical GSM LNA with the same specification and -5 dBm IIP3 takes over 10 mW
- To achieve low power most gain should be after selectivity filters, but high selectivity filters increase cost
- In VCO low phase noise requirement means usually more power consumption because resonance circuit power should be high

# Power consumption, Superhet vs. Direct Conversion

- Sometimes it is claimed that direct conversion receiver consumes more power than superheterodyne receiver
- Claim is true if good IF filters are used in superhet and most gain is after that filtering
- However situation is reverse if we compare receivers with same size and cost
- To get direct conversion size and cost with superheterodyne receiver, very small and cheap IF filters must be used and then current is higher to achieve linearity
- So the practical implementation affects power consumption more than the receiver principle

# Multiband

- Most new products today are dualband
  - 900/1800 in GSM and 800/1900 in US-systems
- With WCDMA and extra RF features like Bluetooth and GPS we may see up to five frequency bands in the same phone
- Multiple switchable filters are costly and take a lot of space in multiband RF
- Direct conversion architecture is optimal for multimode RF engines
- Multicarrier proposals coming (CDMA2000, multicarrier EDGE?)
- Also antenna design will be very challenging in multiband phones

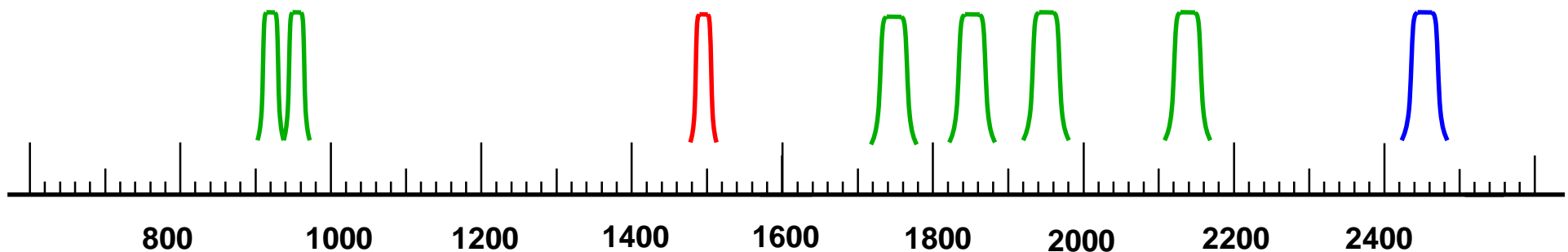

# Frequency bands

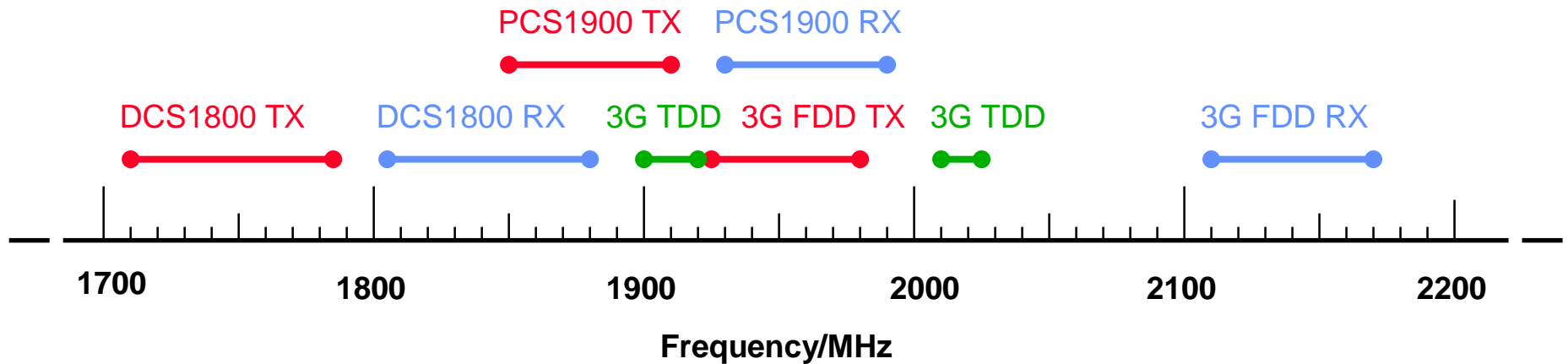
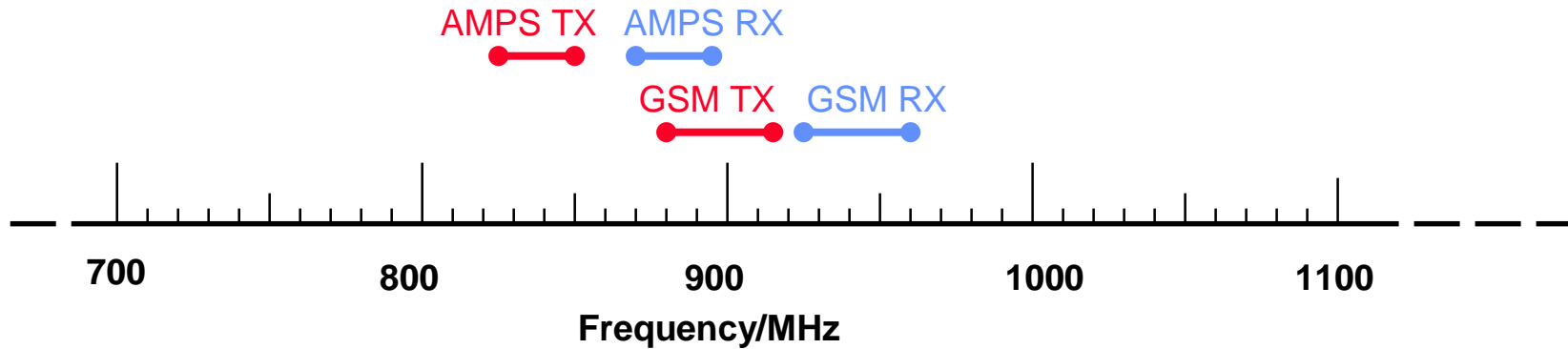



# Proposed framework for global implementation of IMT-2000 in the 2GHz frequency range

## ITU identifications

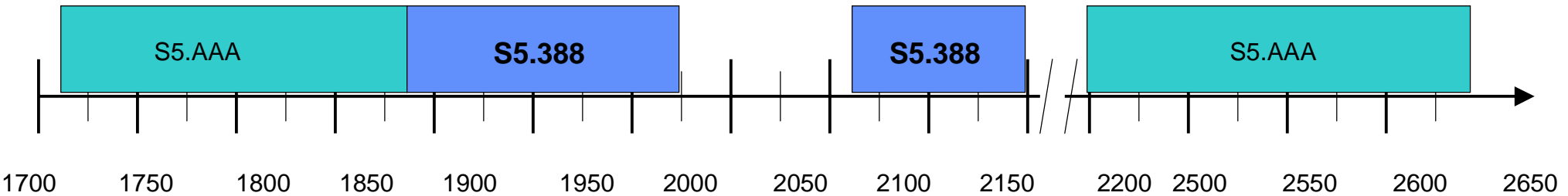

## Examples of current usage

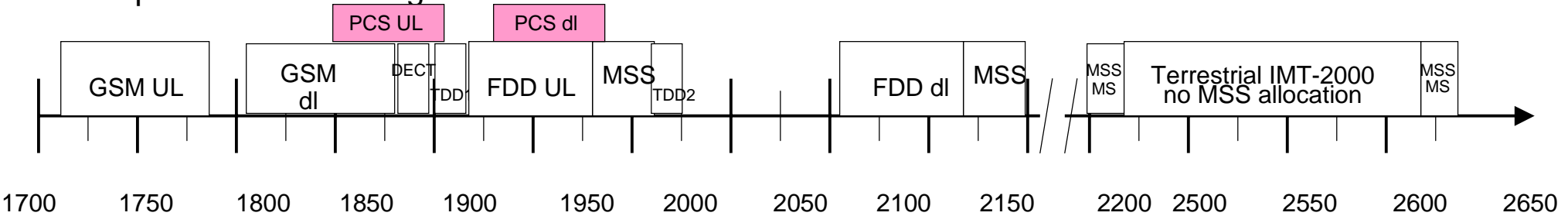

## Proposal for the long term objective:

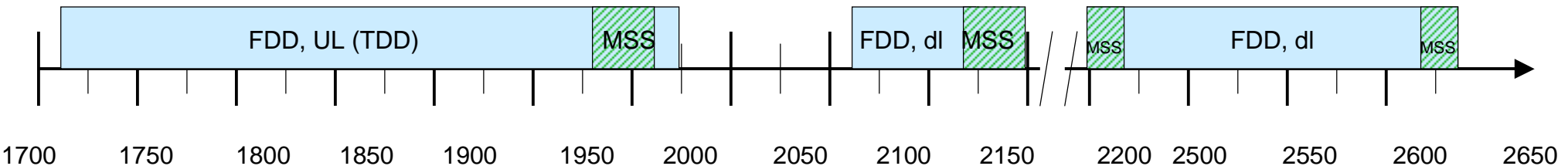

# References

- WCDMA specification work
  - <http://www.3gpp.org/>
- APLAC info from HUT (e.g. manuals)
  - <http://www.aplac.hut.fi/aplac/>

## 射频和天线设计培训课程推荐

易迪拓培训([www.edatop.com](http://www.edatop.com))由数名来自于研发第一线的资深工程师发起成立,致力并专注于微波、射频、天线设计研发人才的培养;我们于 2006 年整合合并微波 EDA 网([www.mweda.com](http://www.mweda.com)),现已发展成为国内最大的微波射频和天线设计人才培养基地,成功推出多套微波射频以及天线设计经典培训课程和 ADS、HFSS 等专业软件使用培训课程,广受客户好评;并先后与人民邮电出版社、电子工业出版社合作出版了多本专业图书,帮助数万名工程师提升了专业技术能力。客户遍布中兴通讯、研通高频、埃威航电、国人通信等多家国内知名公司,以及台湾工业技术研究院、永业科技、全一电子等多家台湾地区企业。

易迪拓培训课程列表: <http://www.edatop.com/peixun/rfe/129.html>



### 射频工程师养成培训课程套装

该套装精选了射频专业基础培训课程、射频仿真设计培训课程和射频电路测量培训课程三个类别共 30 门视频培训课程和 3 本图书教材;旨在引领学员全面学习一个射频工程师需要熟悉、理解和掌握的专业知识和研发设计能力。通过套装的学习,能够让学员完全达到和胜任一个合格的射频工程师的要求...

课程网址: <http://www.edatop.com/peixun/rfe/110.html>

### ADS 学习培训课程套装

该套装是迄今国内最全面、最权威的 ADS 培训教程,共包含 10 门 ADS 学习培训课程。课程是由具有多年 ADS 使用经验的微波射频与通信系统设计领域资深专家讲解,并多结合设计实例,由浅入深、详细而又全面地讲解了 ADS 在微波射频电路设计、通信系统设计和电磁仿真设计方面的内容。能让您在最短的时间内学会使用 ADS,迅速提升个人技术能力,把 ADS 真正应用到实际研发工作中去,成为 ADS 设计专家...



课程网址: <http://www.edatop.com/peixun/ads/13.html>



### HFSS 学习培训课程套装

该套课程套装包含了本站全部 HFSS 培训课程,是迄今国内最全面、最专业的 HFSS 培训教程套装,可以帮助您从零开始,全面深入学习 HFSS 的各项功能和在多个方面的工程应用。购买套装,更可超值赠送 3 个月免费学习答疑,随时解答您学习过程中遇到的棘手问题,让您的 HFSS 学习更加轻松顺畅...

课程网址: <http://www.edatop.com/peixun/hfss/11.html>

## CST 学习培训课程套装

该培训套装由易迪拓培训联合微波 EDA 网共同推出,是最全面、系统、专业的 CST 微波工作室培训课程套装,所有课程都由经验丰富的专家授课,视频教学,可以帮助您从零开始,全面系统地学习 CST 微波工作的各项功能及其在微波射频、天线设计等领域的设计应用。且购买该套装,还可超值赠送 3 个月免费学习答疑...

课程网址: <http://www.edatop.com/peixun/cst/24.html>



## HFSS 天线设计培训课程套装

套装包含 6 门视频课程和 1 本图书,课程从基础讲起,内容由浅入深,理论介绍和实际操作讲解相结合,全面系统的讲解了 HFSS 天线设计的全过程。是国内最全面、最专业的 HFSS 天线设计课程,可以帮助您快速学习掌握如何使用 HFSS 设计天线,让天线设计不再难...

课程网址: <http://www.edatop.com/peixun/hfss/122.html>

## 13.56MHz NFC/RFID 线圈天线设计培训课程套装

套装包含 4 门视频培训课程,培训将 13.56MHz 线圈天线设计原理和仿真设计实践相结合,全面系统地讲解了 13.56MHz 线圈天线的工作原理、设计方法、设计考量以及使用 HFSS 和 CST 仿真分析线圈天线的具体操作,同时还介绍了 13.56MHz 线圈天线匹配电路的设计和调试。通过该套课程的学习,可以帮助您快速学习掌握 13.56MHz 线圈天线及其匹配电路的原理、设计和调试...

详情浏览: <http://www.edatop.com/peixun/antenna/116.html>



### 我们的课程优势:

- ※ 成立于 2004 年,10 多年丰富的行业经验,
- ※ 一直致力并专注于微波射频和天线设计工程师的培养,更了解该行业对人才的要求
- ※ 经验丰富的一线资深工程师讲授,结合实际工程案例,直观、实用、易学

### 联系我们:

- ※ 易迪拓培训官网: <http://www.edatop.com>
- ※ 微波 EDA 网: <http://www.mweda.com>
- ※ 官方淘宝店: <http://shop36920890.taobao.com>