

SEIKO

セイコーNPC株式会社

SEIKO NPC CORPORATION

NPC INTERNAL USE ONLY

2007年9月4日

Power & Backlight Driver

- SM812x/813x/814x –
- SM815x/SM817x series -

September 2007

Seiko NPC Corporation

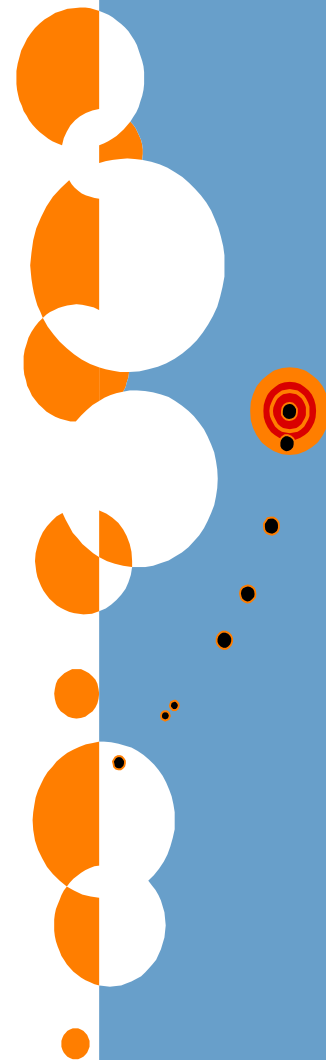

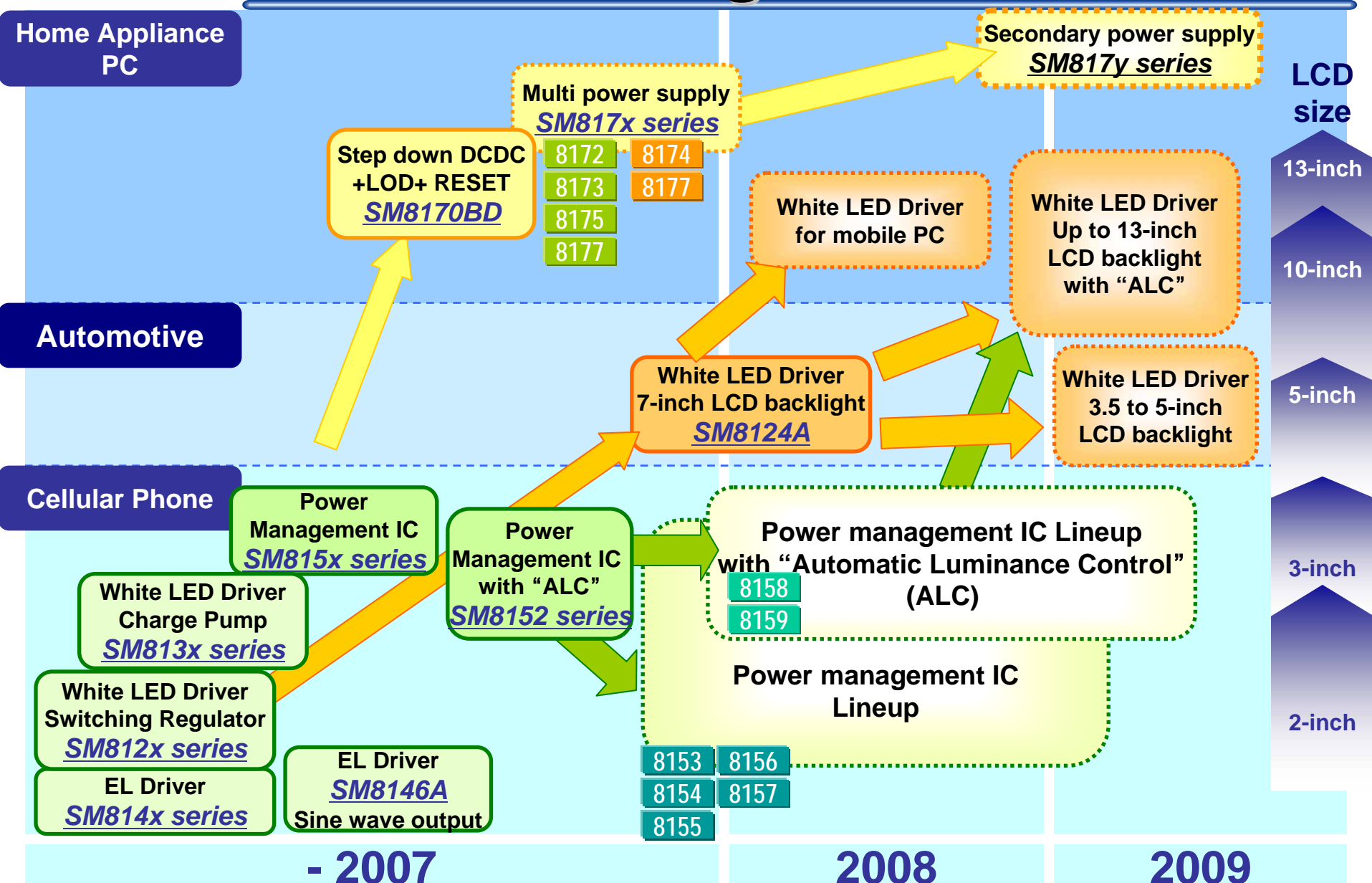

Step down DCDC
+LOD+ RESET
SM8170BD

Multi power supply
SM817x series

- 8172
- 8173
- 8175
- 8177
- 8174
- 8177

Secondary power supply
SM817y series

White LED Driver
for mobile PC

White LED Driver
Up to 13-inch
LCD backlight
with "ALC"

White LED Driver
7-inch LCD backlight
SM8124A

White LED Driver
3.5 to 5-inch
LCD backlight

Power
Management IC
SM815x series

Power
Management IC
with "ALC"
SM8152 series

Power management IC Lineup
with "Automatic Luminance Control"
(ALC)

White LED Driver
Charge Pump
SM813x series

White LED Driver
Switching Regulator
SM812x series

EL Driver
SM814x series

EL Driver
SM8146A
Sine wave output

- 8153
- 8154
- 8155
- 8156
- 8157



White LED Driver Line-up

	Switching Regulator			Charge pump							New	Prelim
	SM8120A	SM8121A	SM8122A	SM8130A	SM8131B	SM8133B	SM8134A	SM8135A	SM8135B	SM8136		
Charge Pump	-	-	-	x2	x1.5	x1.5	x1.5	x1.5,x2	x1.5,x2	x1.5,x2		
LED (max/ch)	<u>2~4</u> 20.8mA	<u>2~6</u> 20.8mA	<u>2~6</u> 20.8mA	<u>3</u> 20mA	<u>6</u> 20mA	<u>6</u> 30mA	<u>4</u> 30mA	<u>4</u> 20mA	<u>4</u> 20mA	<u>3</u> 20mA		
Flash (max)	-	-	-	-	-	<u>1</u> 150mA	<u>1</u> 150mA	-	-	-		
LED grouping	-	-	-	-	Yes	Yes	-	-	-	-		
Dimming	Yes	Yes	Yes	Yes	Yes 16step	Yes 16step	Yes 16step	Yes	Yes 14step	Yes 16step		
Control	DC or PWM	DC or PWM	DC or PWM	CONT pin	EN1/2 pins	3-wire	3-wire	PWM	Pulse	Pulse		
LDO	-	-	-	-	-	<u>1</u>	-	-	-	-		
Package	SOT23-5	*SOT23-5 *SON-6	*SOT23-6 *SON-6	SON-10	QFN-20	QFN-20	QFN-16	QFN-16	QFN-16	TBD QFN-12 or QFN-16		
Outline mm x mm	2.9x1.6	2.9x1.6 2.6x1.6	2.9x1.6 2.0x1.8	2.8x2.9	4.0x4.0	4.0x4.0	3.0x3.0	3.0x3.0	3.0x3.0	TBD 2.0x2.0 or 2.5x2.5		
Status	MP	MP	MP	MP	MP	MP	MP	MP	MP	MP	Sample available	Sample Oct. '07

■ SM8135B

- ◆ 4灯LED Driver
- ◆ 以SM8135A為Base
- ◆ 相異点 A Version: P W M調光
B Version: Pulse count調光

■ SM8136A

- ◆ 3灯LED Driver 新方式CP電路=特性·效率Up
- ◆ 2mm x 2mm QFN-12的小型PKG
- ◆ Pulse count調光

■ Features

- ◆ 1.0/ × 1.5/ × 2.0 auto-switching charge pump boost for increased battery life
- ◆ 1 to 4 white parallel LEDs drive capability
- ◆ LED drive current set by external resistor
- ◆ EN 1-wire input control interface
- ◆ Startup soft start circuit built-in
- ◆ Thermal protection circuit built-in
- ◆ Input voltage range
- ◆ No load ($I_{out} = 0\text{mA}$) : 2.7 to 4.6[V]
- ◆ With load ($I_{out} = 80\text{mA}$) : 3.0 to 4.6[V]
- ◆ Maximum output current : 80[mA] (typ)
- ◆ Standby mode current : 0.01[μA] (typ)
- ◆ Operating frequency : 1.0[MHz](typ)
- ◆ LED current : 20[mA]
- ◆ 4-channel current accuracy : $\pm 5.0\%$
- ◆ Miniature QFN16 package(3.0mm × 3.0mm)

■ Sample, Evaluation board

- ◆ Sample : Now
- ◆ Evaluation board : Now
- ◆ Production : October, 2007

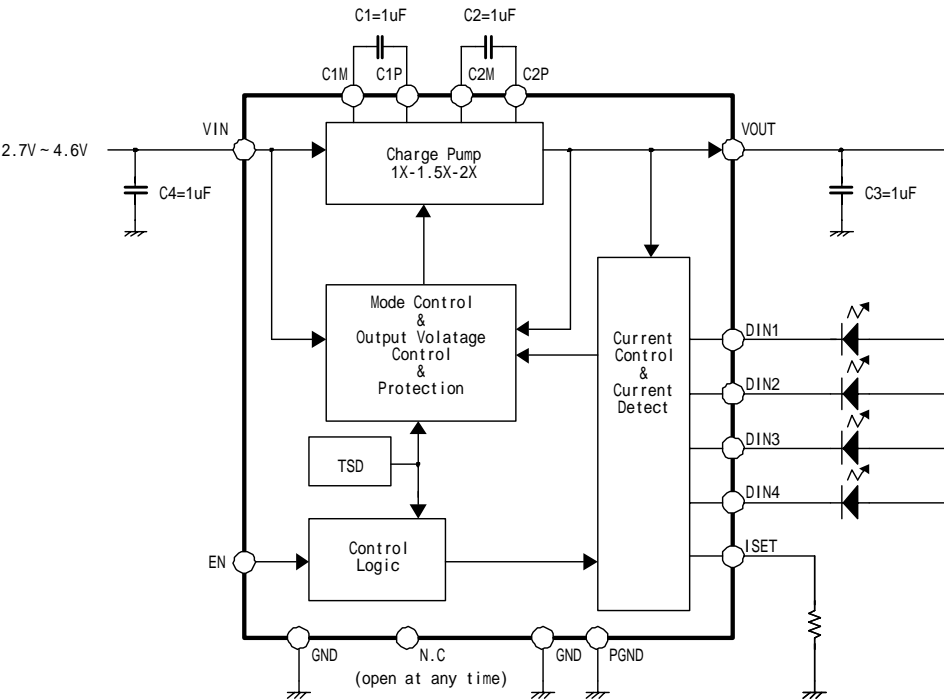

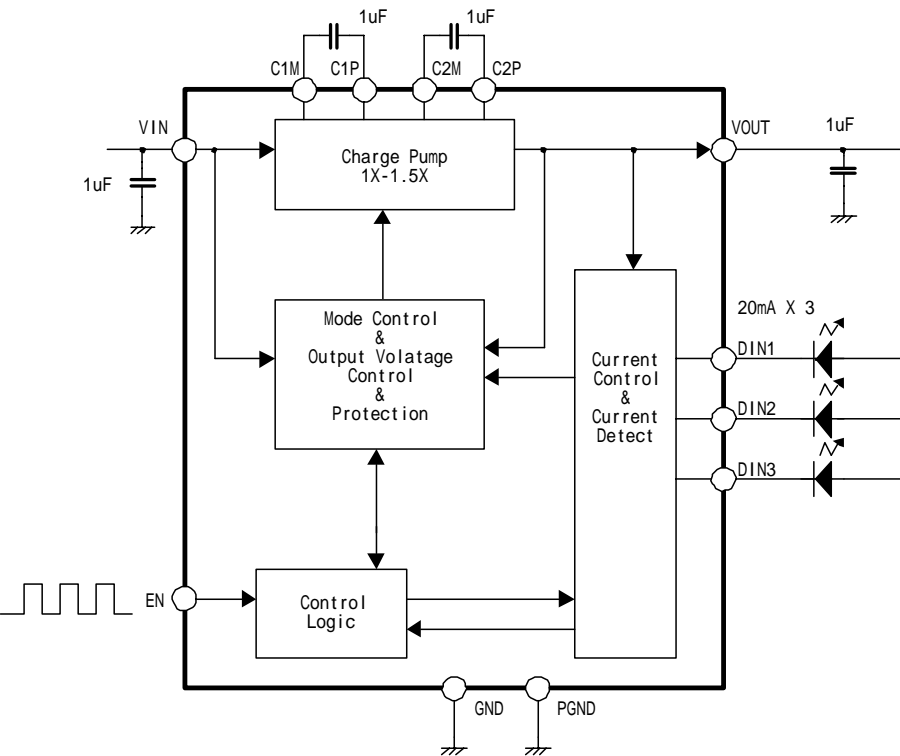

■ Features

- ◆ x1.0/x1.5 auto-switching charge pump boost for increased battery life
- ◆ 1 to 3 white parallel LEDs drive capability
- ◆ EN 1-wire input control interface
- ◆ Startup soft start circuit built-in
- ◆ Input voltage range
- ◆ No load ($I_{out} = 0\text{mA}$) : 2.7 to 4.6[V]
- ◆ With load ($I_{out} = 60\text{mA}$) : 3.0 to 4.6[V]
- ◆ Maximum output current : 60[mA] (typ)
- ◆ Standby mode current : 0.01[μA] (typ)
- ◆ Operating frequency : 1.0[MHz](typ)
- ◆ x1.0<>x1.5 Transition Voltage(fall&rise)
 - : $V_f + 0.16\text{V}(20\text{mA})$
 - : $V_f + 0.12\text{V}(15\text{mA})$
- ◆ LED current : 20[mA]
- ◆ 3-channel current accuracy : $\pm 5.0\%$
- ◆ Miniature QFN12 package(2.0mm x 2.0mm)

■ Sample, Evaluation board

- ◆ Sample : October, 2007
- ◆ Evaluation board : October, 2007
- ◆ Production : January, 2008

Performance comparison

	SM8136A	RT9364 (Richtech)	AAT3157 (AnalogicTech)	CAT3644 (Catalyst)
Charge Pump Type	1/1.5	1/1.5	1/1.5/2	1/1.33/1.5/2
LED number	3	4	3	4
PKG	QFN12	QFN16	TSOPJW12	TQFN16
Size(mm)	(2.0 × 2.0 × 0.7)	3.0 × 3.0 × 0.75	2.85X3.0X1.0	3.0 × 3.0 × 0.75
x1.0 x1.5(20mA)	Vf+0.16V	(Vf+0.19V)	Vf+0.20V	Vf+0.25V
x1.0 x1.5(15mA)	Vf+0.12V	Vf+0.14V	(Vf+0.15V)	(Vf+0.19V)
x1.5 x1.0(20mA)	Vf+0.16V	(Vf+0.39V)	?	Vf+0.65V
x1.5 x1.0(15mA)	Vf+0.12V	Vf+0.34V	?	(Vf+0.59V)

NPC Power Management IC Line-up

	SM8150	SM8152	New SM8153	New SM8154	New SM8155	New SM8156	New SM8157	New SM8158A	Prelim SM8158B	Prelim SM8159
Charge Pump	x1.5,x2	x1.5,x2	x1.5,x2	x1.5,x2	x1.5,x2	x1.5,x2	x1.5,x2	x1.5,x2	x1.5,x2	x1.5,x2
LED (max/ch)	<u>6</u> 25mA	<u>4</u> 25mA	<u>4</u> 25mA	<u>4</u> 25mA	<u>4</u> 25mA	<u>6</u> 25mA	<u>6</u> 25mA	<u>6</u> 25mA	<u>7</u> 25mA	<u>6</u> 25mA
Flash (max)	<u>1</u> 300mA	<u>1</u> 155mA	-	<u>1</u> 155mA	-	-	<u>1</u> 155mA	-	-	-
LED grouping	(Yes)	-	Yes	Yes	Yes	Yes	Yes	Yes	Yes	Yes
Dimming	Yes 32step	Yes 32step	Yes 32step	Yes 32step	Yes 32step	Yes 32step	Yes 32step	Yes 32step	Yes 32step	Yes 32step
ALC	-	Yes	-	-	-	-	-	Yes	Yes	Yes
Fade In/Out	-	-	Yes	Yes	Yes	Yes	Yes	Yes	Yes	Yes
LDO	<u>2</u>	<u>4</u> *	<u>4</u>	<u>2</u>	<u>2</u>	<u>6</u> *	<u>4</u> *	<u>2</u>	<u>2</u>	-
DC/DC	<u>1</u>	-	-	-	-	-	-	-	-	-
GPO	-	-	-	-	-	-	<u>2</u>	<u>4</u>	<u>3</u>	-
Control	I ² C	I ² C	I ² C	I ² C	I ² C	I ² C	I ² C	I ² C	I ² C	I ² C
Package	QFN28	QFN28	QFN20	QFN20	QFN20	QFN28	QFN28	QFN28	QFN28	QFN20
Outline mm x mm	4.0 × 4.0	4.0 × 4.0	3.0x3.0	3.0x3.0	3.0x3.0	3.5 × 3.5	3.5 × 3.5	3.5 × 3.5	3.5 × 3.5	3.0x3.0
Status	MP	MP	Sample available	Sample available	Sample available	Sample available	Sample available	Sample Sep. '07	Sample Sep.'07	Sample Oct.'07

■ SM8152 =NPC最早的 內建自動調光功能 IC

■ SM8153 ~ 8157

- ◆ 8153~8155 : 3.0mm QFN-20 package
- ◆ 8156, 8157 : 3.5mm QFN-28 package
- ◆ Software、Pin排列的一致性
- ◆ LED4 or 6灯, Grouping, Flash, LDO 2 ~ 6個輸出

■ SM8158A/B

- ◆ 以8156/57為Base+內建自動調光機能 (Pin排列一致性)
- ◆ LED6 or 7灯, Grouping, LDO輸出, GPO Port 3 or 4個輸出

■ SM8159A

- ◆ 8158的簡略版 (與8153 ~ 55 Pin排列一致性)
- ◆ LED6灯, Grouping。功能單純: Driver + 自動調光機能

QFN-20 3.0mm x 3.0mm

<8153>

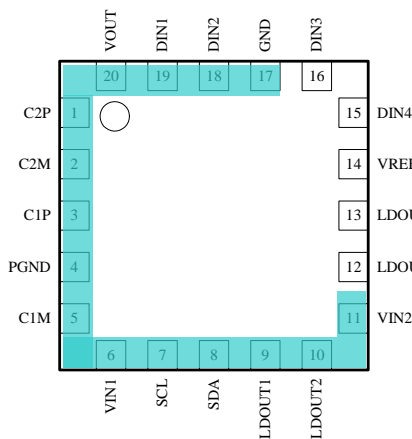

<8154>

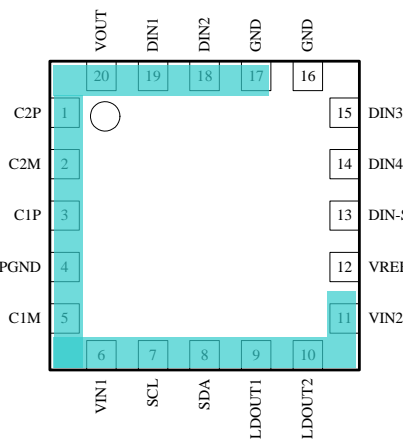

<8155>

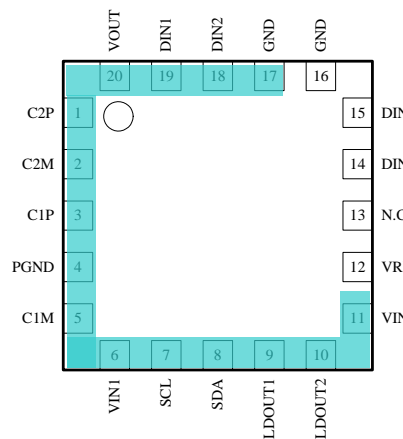

<8159>

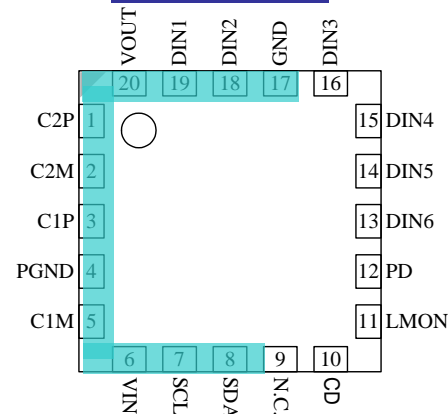

QFN-28 3.5mm x 3.5mm

<8156>

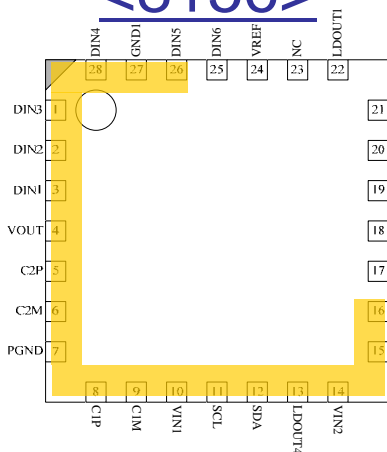

<8157>

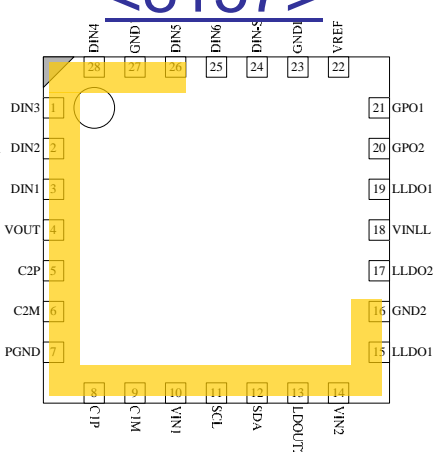

<8158A>

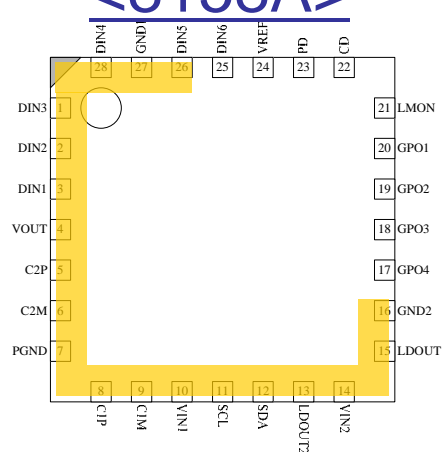

<8158B>

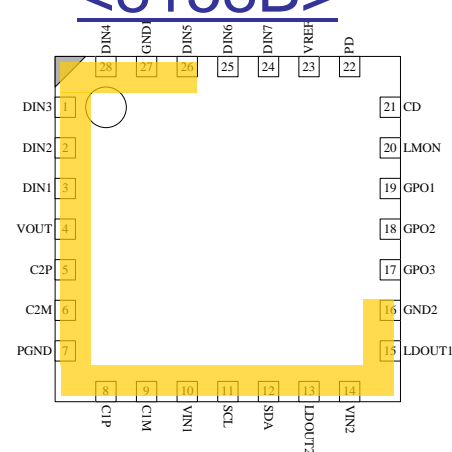

SM8153

4LED+4LDO

3.0mm x 3.0mm QFN-20

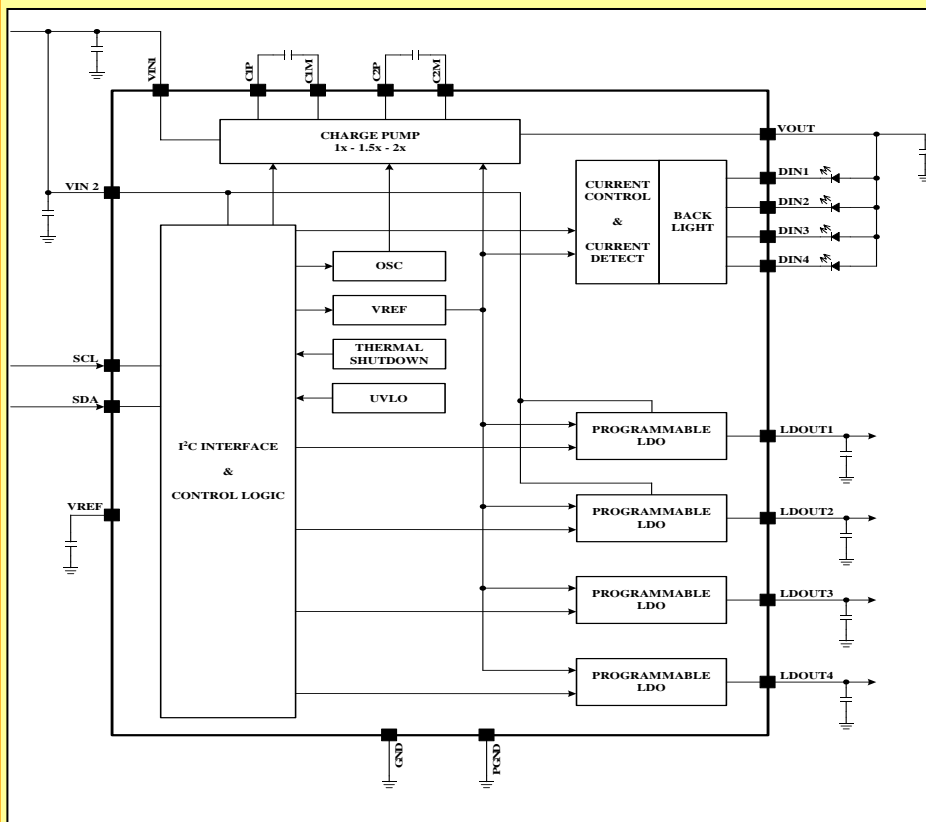

SM8156

6LED+6LDO

3.5mm x 3.5mm QFN-28

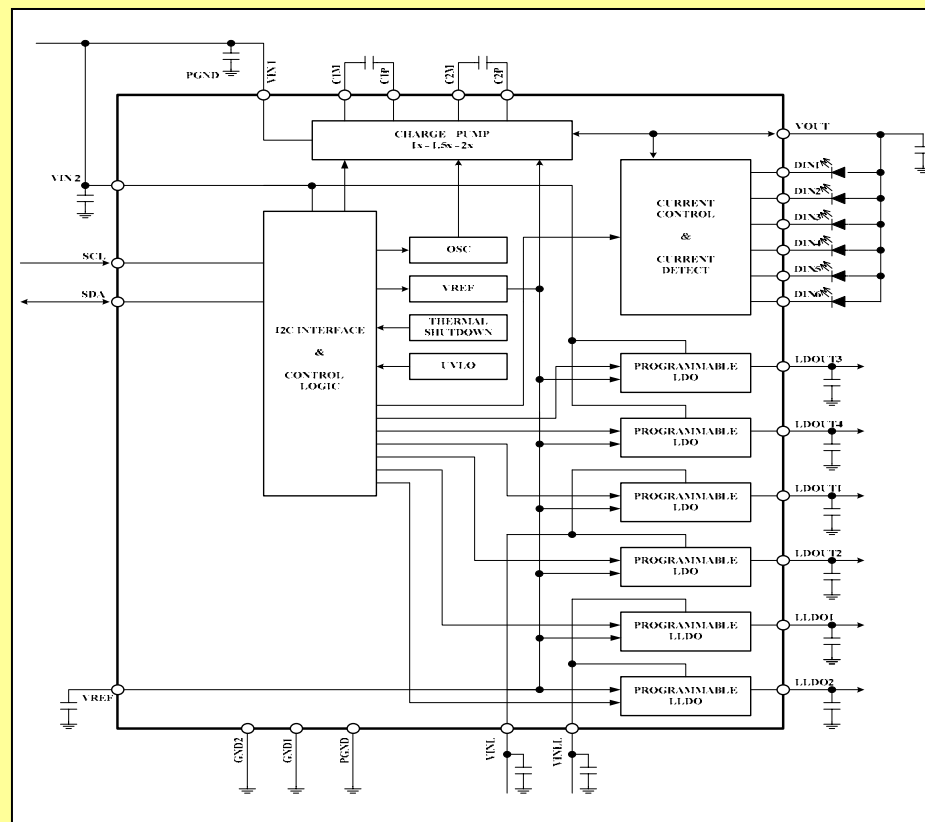

SM8158/8159特徵

<改善自動調光功能>

- PD輸入精度Up
- 提昇功能(Max save 4段階)

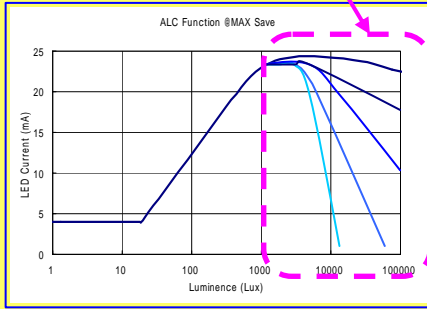

SM8158B

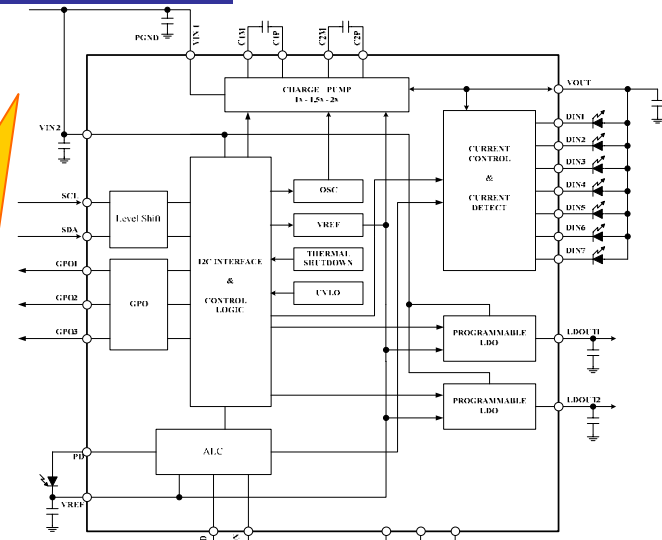

SM8159

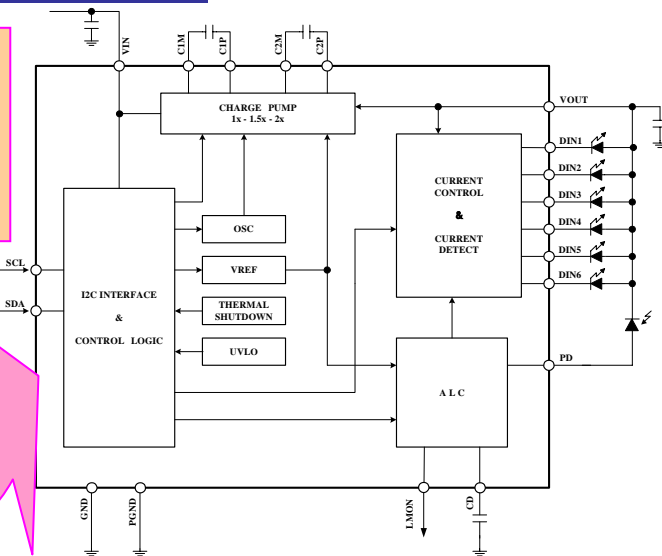

簡略版
削減LDO等功能,
僅用於背光用

SM8152

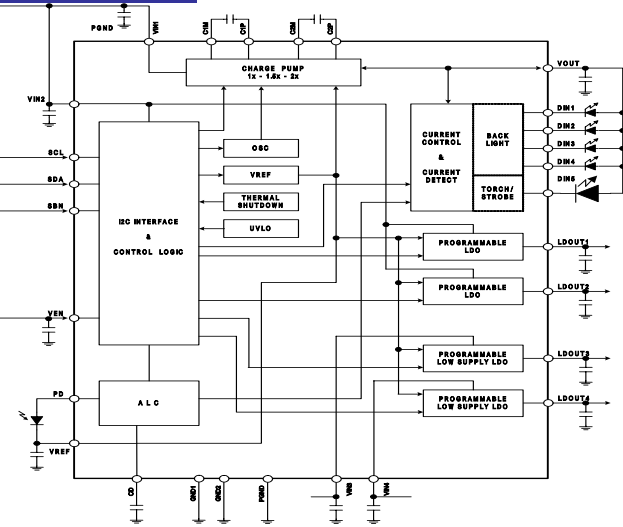

■ Fade-in / Fade-out

◆ LED漸続点灯 / 漸続熄灯 (1s和0.5s兩種選択)

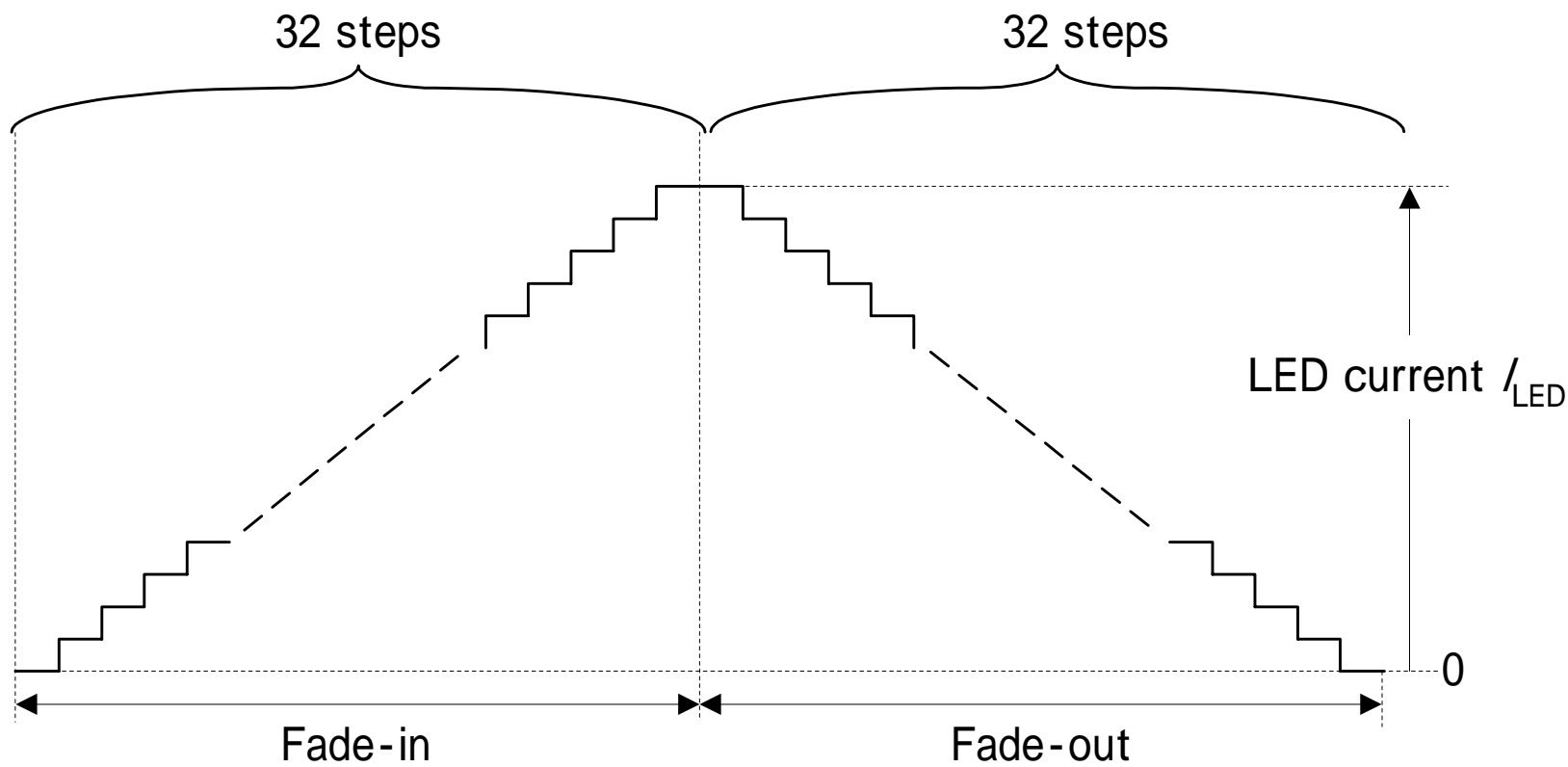

■ GPO :

- ◆ 又稱為Port Expander
- ◆ 20mA定電流Driver。輸出Open Drain
- ◆ I2C可僅用在控制ON/OFF此一功能而已。
- ◆ VDD可連接外部電路、作PWM調光。

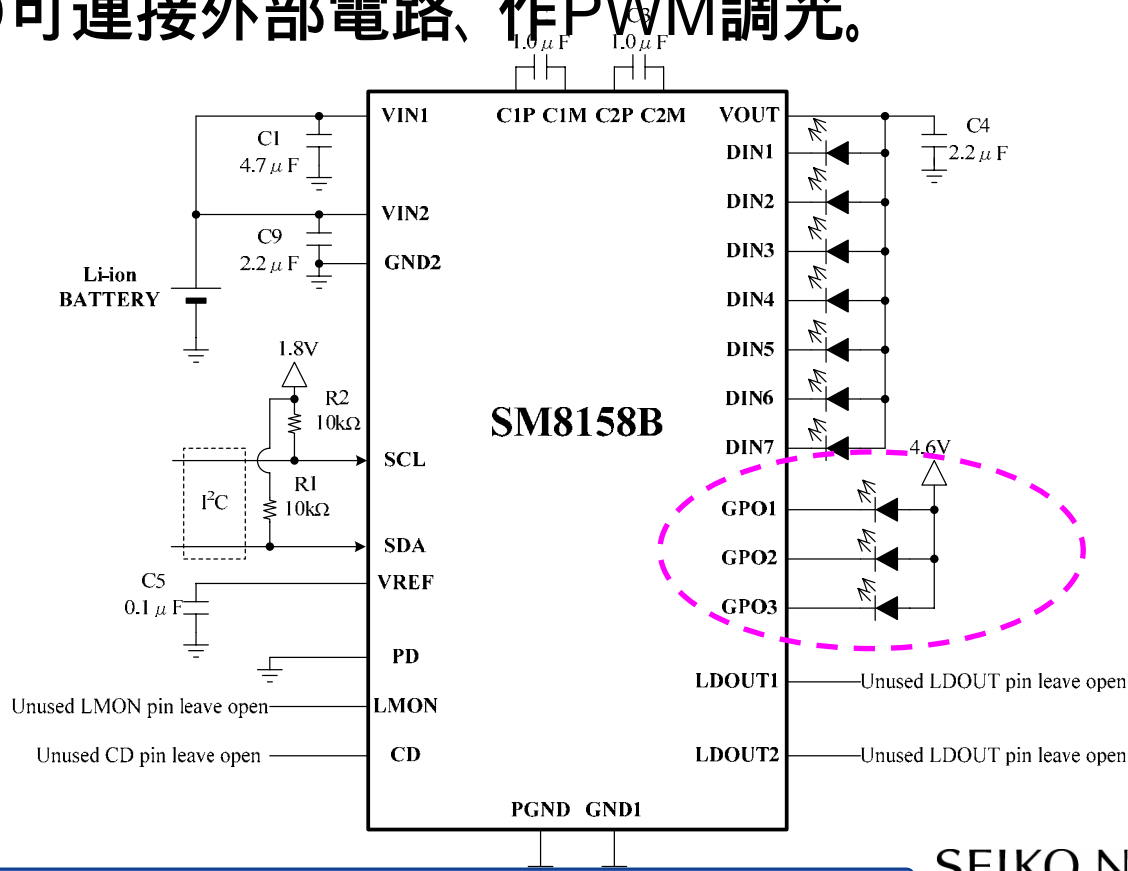

自動調光 (ALC) 機能概要

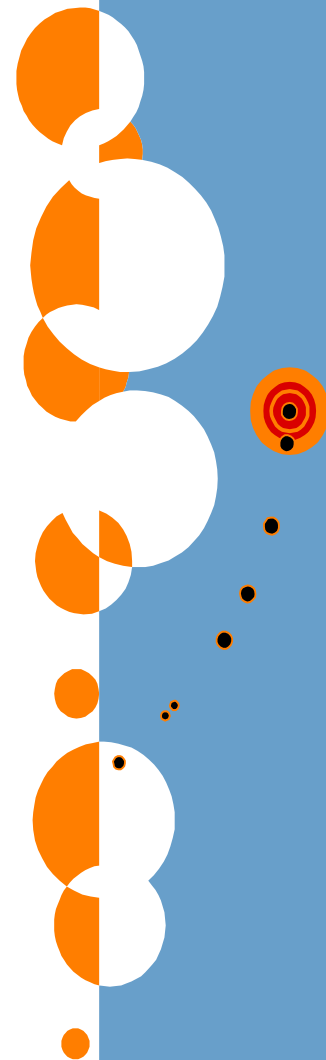

■ 主要特徵

- ◆ 広範のPhoto Sensor輸入電流範圍:0.01uA ~ 5mA

Photo Diode、Photo IC兩者皆可

- ◆ 平順 (Smooth)的LED亮度变化 (非段階性的！)
- ◆ 經由I2C程式控制、ALC功能設定簡單 (実装後也能設定)

■ 其他特徵

- ◆ 広範のALC控制特性、広範の控制点 (Point)設定範圍
- ◆ 内建Delay電路、可任意調整LED亮度变化
可個別調整 漸暗(亮 暗)、漸亮(暗 亮)功能:1s ~ 10s (@C=1uF)
- ◆ 内建Limiter、可設定LED電流最大值 / 最小值
(設定範圍:最大(19 ~ 25mA)、最小(1 ~ 4mA))
- ◆ 經由LMON端子 (0.3 ~ 2.0Vtyp)可同時調整Keypad亮度

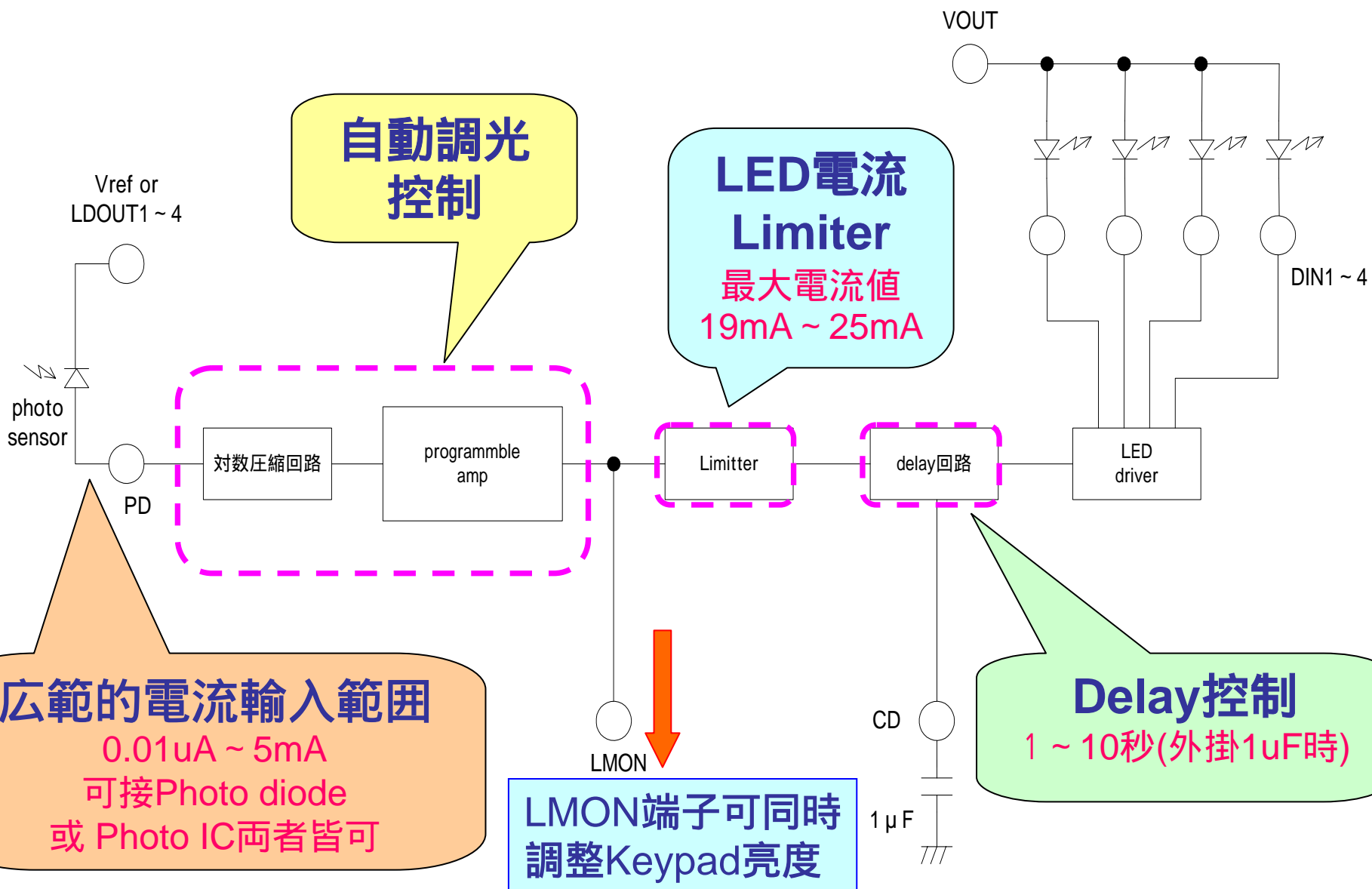

**自動調光
控制**

**LED電流
Limiter**
最大電流值
19mA ~ 25mA

Delay控制
1 ~ 10秒(外掛1uF時)

広範的電流輸入範圍
0.01uA ~ 5mA
可接Photo diode
或 Photo IC兩者皆可

**LMON端子可同時
調整Keypad亮度**

■ 広範のALC制御特性、広範の制御点(Point)設定範囲



図1 . ALC制御特性



図2 . ALC制御点(Point)

■ Limiter電路

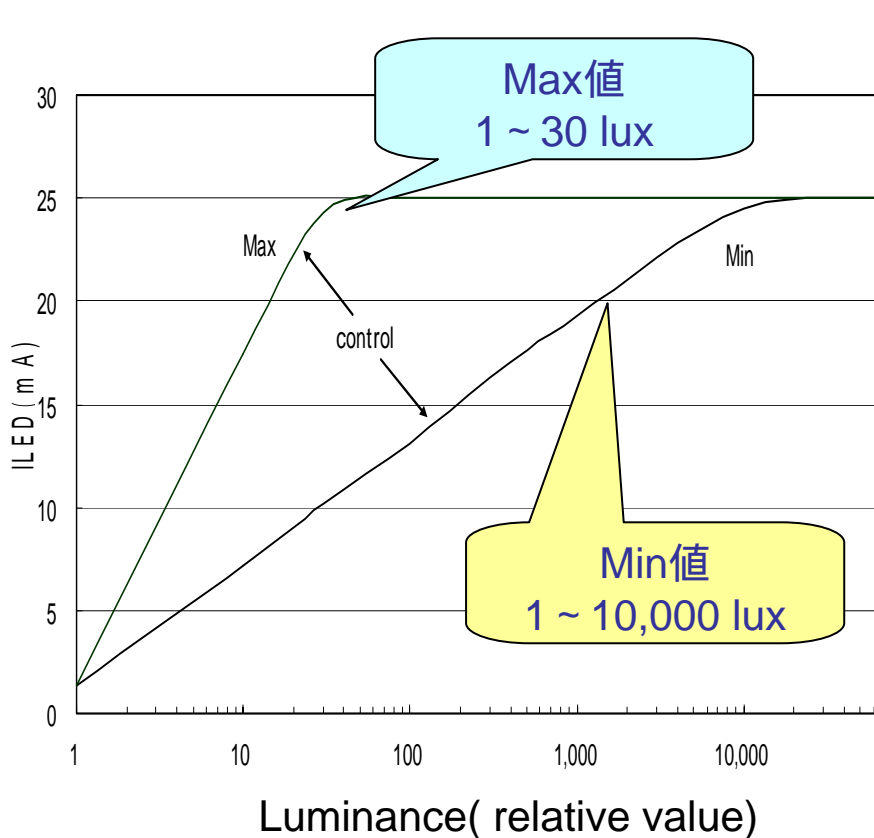
- ◆ 能控制LED電流、以免LED遭破壞。同時也能控制 不要的消費電流 的增加

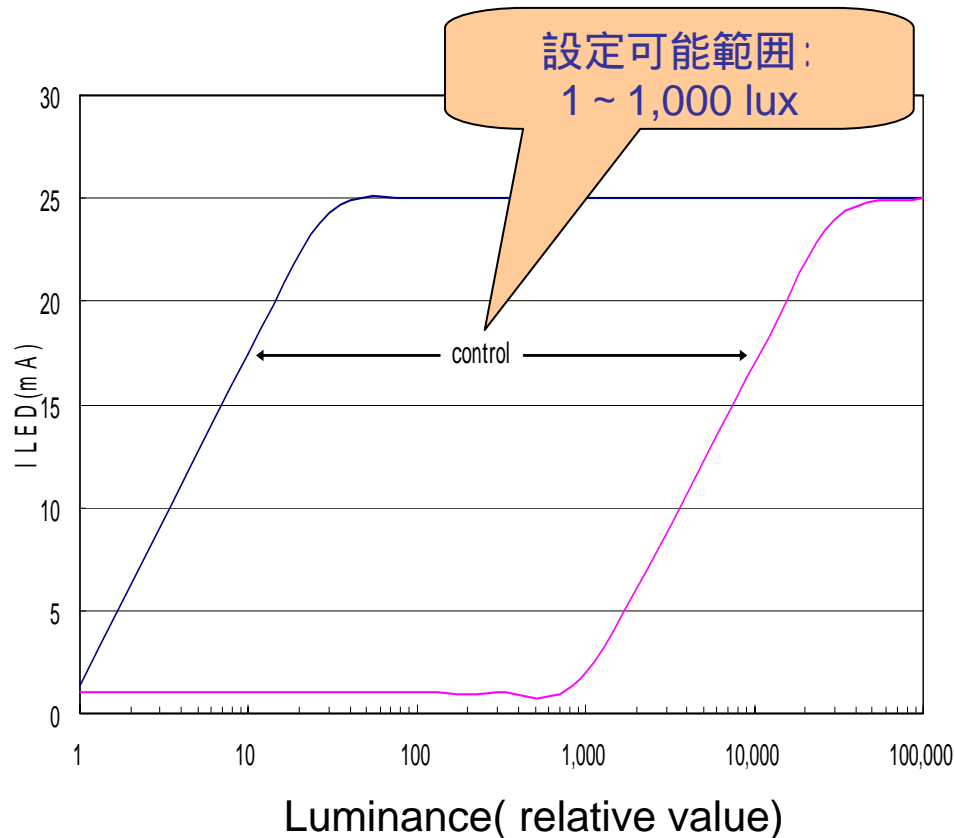
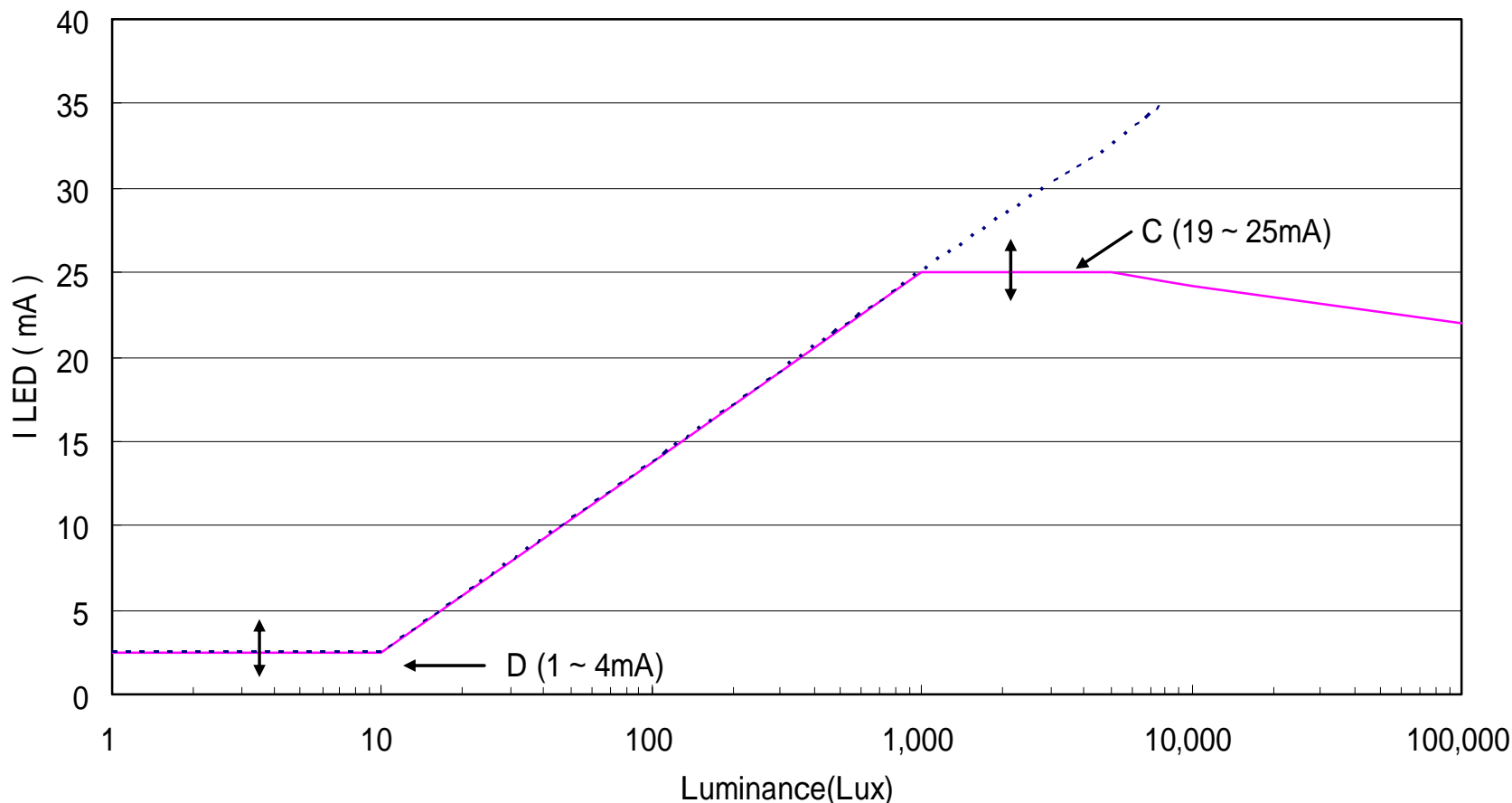

■ 使用ALC時的節省能源效果

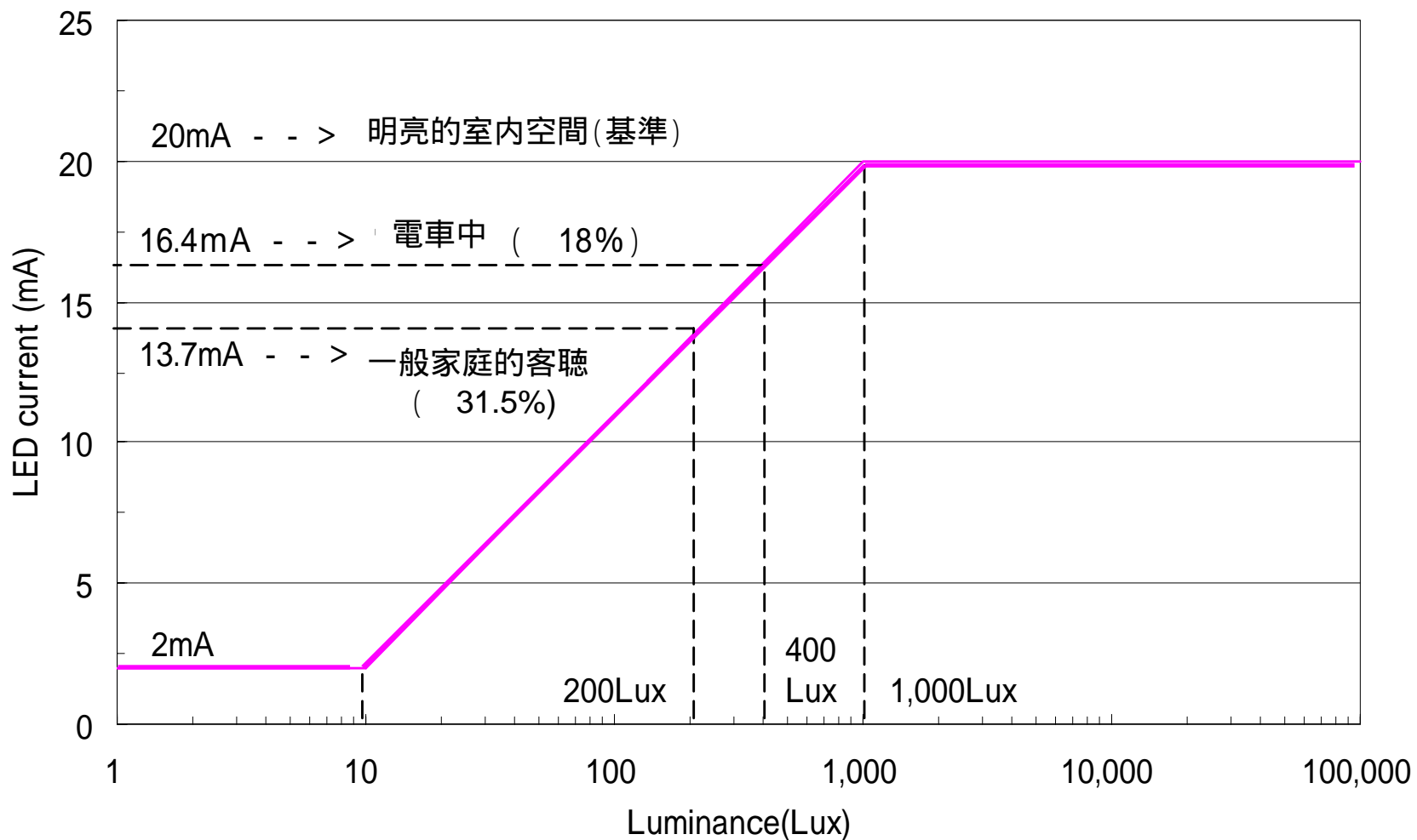

■ Delay電路-1 ~ 10秒 (C=1uF時)的範圍內
可設定3 2位階

- ◆可個別調整 漸暗(亮 暗)漸亮(暗 亮)功能
例)漸亮4秒、漸暗1秒

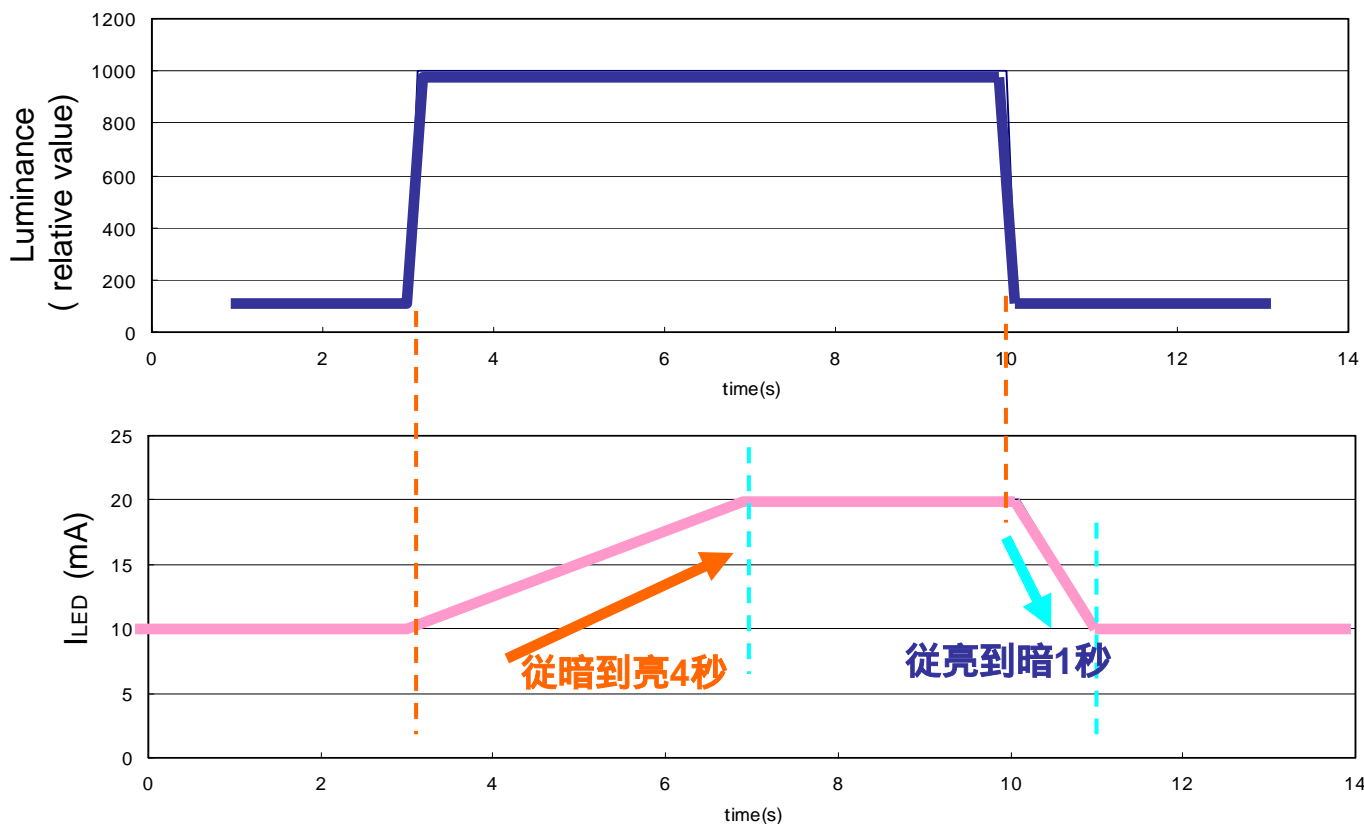

			New	New	Prelim	New	New	Prelim	
		SM8170B	SM8172A	SM8173A	SM8174A	SM8175A	SM8176A	SM8177A	
DC/DC	Step-up	-	-	<u>400mA</u> <u>5.0 to 11.5V</u>	-	-	<u>400mA</u> <u>5.0 to 11.5V</u>	-	
	Step-up/down	-	-	-	<u>500mA</u> <u>5.0 to 11.5V</u>	-	-	-	
	Step-down *Option=()	1	<u>800mA</u> <u>1.0 to 3.0V</u>	<u>800mA</u> <u>1.2V</u> (1.0 to 1.8V)	-	-	<u>800mA</u> <u>1.2V</u> (1.0 to 1.8V)	<u>600mA</u> <u>1.2V</u> (1.0 to 1.8V)	<u>500mA</u> <u>1.0 to 3.3V</u>
		2	-	-	-	-	<u>600mA</u> <u>3.3V</u> (1.9 to 3.6V)	<u>600mA</u> <u>3.3V</u> (1.9 to 3.6V)	<u>1A</u> <u>1.0 to 3.3V</u>
3		-	-	-	-	-	-	<u>2A</u> <u>1.0 to 3.3V</u>	
LDO / 3.3V (2.1 to 3.6V option)		<u>400mA</u>	<u>400mA</u>	-	-	-	-	-	
Reset / 3.9V detect (3.2~4.2V option)		Yes	Yes	-	-	Yes	Yes	-	
Package		SON10	SON10	SON10	SON10	QFN-16	QFN-20	QFN-28	
Outline (mm x mm)		2.5 x 3.0	2.5 x 3.0	2.5 x 3.0	2.5 x 3.0	2.5x2.5	3.0x3.0	3.5x3.5	
Status		MP	Sample Oct. 2007	Sample Oct. 2007	Sample -	Sample Oct. 2007	Sample Nov. 2007	Sample -	

射频和天线设计培训课程推荐

易迪拓培训(www.edatop.com)由数名来自于研发第一线的资深工程师发起成立,致力并专注于微波、射频、天线设计研发人才的培养;我们于 2006 年整合合并微波 EDA 网(www.mweda.com),现已发展成为国内最大的微波射频和天线设计人才培养基地,成功推出多套微波射频以及天线设计经典培训课程和 ADS、HFSS 等专业软件使用培训课程,广受客户好评;并先后与人民邮电出版社、电子工业出版社合作出版了多本专业图书,帮助数万名工程师提升了专业技术能力。客户遍布中兴通讯、研通高频、埃威航电、国人通信等多家国内知名公司,以及台湾工业技术研究院、永业科技、全一电子等多家台湾地区企业。

易迪拓培训课程列表: <http://www.edatop.com/peixun/rfe/129.html>



射频工程师养成培训课程套装

该套装精选了射频专业基础培训课程、射频仿真设计培训课程和射频电路测量培训课程三个类别共 30 门视频培训课程和 3 本图书教材;旨在引领学员全面学习一个射频工程师需要熟悉、理解和掌握的专业知识和研发设计能力。通过套装的学习,能够让学员完全达到和胜任一个合格的射频工程师的要求...

课程网址: <http://www.edatop.com/peixun/rfe/110.html>

ADS 学习培训课程套装

该套装是迄今国内最全面、最权威的 ADS 培训教程,共包含 10 门 ADS 学习培训课程。课程是由具有多年 ADS 使用经验的微波射频与通信系统设计领域资深专家讲解,并多结合设计实例,由浅入深、详细而又全面地讲解了 ADS 在微波射频电路设计、通信系统设计和电磁仿真设计方面的内容。能让您在最短的时间内学会使用 ADS,迅速提升个人技术能力,把 ADS 真正应用到实际研发工作中去,成为 ADS 设计专家...



课程网址: <http://www.edatop.com/peixun/ads/13.html>



HFSS 学习培训课程套装

该套课程套装包含了本站全部 HFSS 培训课程,是迄今国内最全面、最专业的 HFSS 培训教程套装,可以帮助您从零开始,全面深入学习 HFSS 的各项功能和在多个方面的工程应用。购买套装,更可超值赠送 3 个月免费学习答疑,随时解答您学习过程中遇到的棘手问题,让您的 HFSS 学习更加轻松顺畅...

课程网址: <http://www.edatop.com/peixun/hfss/11.html>

CST 学习培训课程套装

该培训套装由易迪拓培训联合微波 EDA 网共同推出,是最全面、系统、专业的 CST 微波工作室培训课程套装,所有课程都由经验丰富的专家授课,视频教学,可以帮助您从零开始,全面系统地学习 CST 微波工作的各项功能及其在微波射频、天线设计等领域的设计应用。且购买该套装,还可超值赠送 3 个月免费学习答疑...

课程网址: <http://www.edatop.com/peixun/cst/24.html>



HFSS 天线设计培训课程套装

套装包含 6 门视频课程和 1 本图书,课程从基础讲起,内容由浅入深,理论介绍和实际操作讲解相结合,全面系统的讲解了 HFSS 天线设计的全过程。是国内最全面、最专业的 HFSS 天线设计课程,可以帮助您快速学习掌握如何使用 HFSS 设计天线,让天线设计不再难...

课程网址: <http://www.edatop.com/peixun/hfss/122.html>

13.56MHz NFC/RFID 线圈天线设计培训课程套装

套装包含 4 门视频培训课程,培训将 13.56MHz 线圈天线设计原理和仿真设计实践相结合,全面系统地讲解了 13.56MHz 线圈天线的工作原理、设计方法、设计考量以及使用 HFSS 和 CST 仿真分析线圈天线的具体操作,同时还介绍了 13.56MHz 线圈天线匹配电路的设计和调试。通过该套课程的学习,可以帮助您快速学习掌握 13.56MHz 线圈天线及其匹配电路的原理、设计和调试...

详情浏览: <http://www.edatop.com/peixun/antenna/116.html>



我们的课程优势:

- ※ 成立于 2004 年,10 多年丰富的行业经验,
- ※ 一直致力并专注于微波射频和天线设计工程师的培养,更了解该行业对人才的要求
- ※ 经验丰富的一线资深工程师讲授,结合实际工程案例,直观、实用、易学

联系我们:

- ※ 易迪拓培训官网: <http://www.edatop.com>
- ※ 微波 EDA 网: <http://www.mweda.com>
- ※ 官方淘宝店: <http://shop36920890.taobao.com>