

**NORME  
INTERNATIONALE  
INTERNATIONAL  
STANDARD**

**CEI  
IEC**

**61000-4-2**

**Edition 1.2**

2001-04

Edition 1:1995 consolidée par les amendements 1:1998 et 2:2000  
Edition 1:1995 consolidated with amendments 1:1998 and 2:2000

---

---

**PUBLICATION FONDAMENTALE EN CEM  
BASIC EMC PUBLICATION**

---

---

**Compatibilité électromagnétique (CEM) –**

**Partie 4-2:**

**Techniques d'essai et de mesure –**

**Essai d'immunité aux décharges électrostatiques**

**Electromagnetic compatibility (EMC) –**

**Part 4-2:**

**Testing and measurement techniques –**

**Electrostatic discharge immunity test**



Numéro de référence  
Reference number  
CEI/IEC 61000-4-2:1995+A1:1998+A2:2000

**NORME  
INTERNATIONALE  
INTERNATIONAL  
STANDARD**

**CEI  
IEC**

**61000-4-2**

**Edition 1.2**

2001-04

Edition 1:1995 consolidée par les amendements 1:1998 et 2:2000  
Edition 1:1995 consolidated with amendments 1:1998 and 2:2000

---

---

**PUBLICATION FONDAMENTALE EN CEM  
BASIC EMC PUBLICATION**

---

---

**Compatibilité électromagnétique (CEM) –**

**Partie 4-2:  
Techniques d'essai et de mesure –  
Essai d'immunité aux décharges électrostatiques**

**Electromagnetic compatibility (EMC) –**

**Part 4-2:  
Testing and measurement techniques –  
Electrostatic discharge immunity test**

© IEC 2001 Droits de reproduction réservés — Copyright - all rights reserved

Aucune partie de cette publication ne peut être reproduite ni utilisée sous quelque forme que ce soit et par aucun procédé, électronique ou mécanique, y compris la photocopie et les microfilms, sans l'accord écrit de l'éditeur.

No part of this publication may be reproduced or utilized in any form or by any means, electronic or mechanical, including photocopying and microfilm, without permission in writing from the publisher.

International Electrotechnical Commission  
Telefax: +41 22 919 0300

3, rue de Varembe Geneva, Switzerland  
e-mail: [inmail@iec.ch](mailto:inmail@iec.ch) IEC web site <http://www.iec.ch>



Commission Electrotechnique Internationale  
International Electrotechnical Commission  
Международная Электротехническая Комиссия

CODE PRIX  
PRICE CODE

**W**

*Pour prix, voir catalogue en vigueur  
For price, see current catalogue*

## CONTENTS

	Page
FOREWORD .....	5
INTRODUCTION .....	9
Clause	
1 Scope .....	11
2 Normative references .....	13
3 General .....	13
4 Definitions .....	13
5 Test levels .....	17
6 Test generator .....	19
6.1 Characteristics and performance of the ESD generator .....	19
6.2 Verification of the characteristics of the ESD generator .....	21
7 Test set-up .....	23
7.1 Test set-up for tests performed in laboratories .....	23
7.2 Test set-up for post-installation tests .....	29
8 Test procedure .....	31
8.1 Laboratory reference conditions .....	31
8.2 EUT exercising .....	31
8.3 Execution of the test .....	31
9 Evaluation of test results .....	37
10 Test report .....	39
Annex A (informative) Explanatory notes .....	55
Annex B (informative) Constructional details .....	65
Figure 1 – Simplified diagram of the ESD generator .....	39
Figure 2 – Example of arrangement for verification of the ESD generator .....	41
Figure 3 – Typical waveform of the output current of the ESD generator .....	43
Figure 4 – Discharge electrodes of the ESD generator .....	45
Figure 5 – Example of test set-up for table-top equipment – Laboratory tests .....	47
Figure 6 – Example of test set-up for floor-standing equipment, laboratory tests .....	49
Figure 7 – Example of test set-up for floor-standing equipment, post-installation tests .....	51
Figure 8 – Test set-up for ungrounded table-top equipment .....	53
Figure 9 – Test set-up for ungrounded floor-standing equipment .....	53
Figure A.1 – Maximum values of electrostatic voltages to which operators may be charged while in contact with the materials mentioned in clause A.2 .....	63
Figures B.1 to B.7 – Construction details of the resistive load .....	67 to 75
Table 1 – Test levels .....	17
Table 2 – Waveform parameters .....	21
Table A.1 – Guideline for the selection of the test levels .....	57

## INTERNATIONAL ELECTROTECHNICAL COMMISSION

---

### **ELECTROMAGNETIC COMPATIBILITY (EMC) –**

#### **Part 4-2: Testing and measurement techniques – Electrostatic discharge immunity test**

### FOREWORD

- 1) The IEC (International Electrotechnical Commission) is a worldwide organization for standardization comprising all national electrotechnical committees (IEC National Committees). The object of the IEC is to promote international co-operation on all questions concerning standardization in the electrical and electronic fields. To this end and in addition to other activities, the IEC publishes International Standards. Their preparation is entrusted to technical committees; any IEC National Committee interested in the subject dealt with may participate in this preparatory work. International, governmental and non-governmental organizations liaising with the IEC also participate in this preparation. The IEC collaborates closely with the International Organization for Standardization (ISO) in accordance with conditions determined by agreement between the two organizations.
- 2) The formal decisions or agreements of the IEC on technical matters express, as nearly as possible, an international consensus of opinion on the relevant subjects since each technical committee has representation from all interested National Committees.
- 3) The documents produced have the form of recommendations for international use and are published in the form of standards, technical specifications, technical reports or guides and they are accepted by the National Committees in that sense.
- 4) In order to promote international unification, IEC National Committees undertake to apply IEC International Standards transparently to the maximum extent possible in their national and regional standards. Any divergence between the IEC Standard and the corresponding national or regional standard shall be clearly indicated in the latter.
- 5) The IEC provides no marking procedure to indicate its approval and cannot be rendered responsible for any equipment declared to be in conformity with one of its standards.
- 6) Attention is drawn to the possibility that some of the elements of this International Standard may be the subject of patent rights. The IEC shall not be held responsible for identifying any or all such patent rights.

International Standard IEC 61000-4-2 has been prepared by subcommittee 77B: High-frequency phenomena, of IEC technical committee 77: Electromagnetic compatibility.

It forms section 2 of part 4 of IEC 61000. It has the status of a basic EMC publication in accordance with IEC Guide 107.

It is based on the IEC 60801-2 (second edition: 1991): *Electromagnetic compatibility for industrial process measurement and control equipment – Part 2: Electrostatic discharge requirements*, prepared by IEC technical committee 65: Industrial-process measurement and control.

According to a recommendation of ACEC at its meeting of December 1989, the scope of this standard has been extended to all kinds of electrical and electronic equipment. For this purpose it has been decided to transfer the 60801 series of publications to the 61000-4 series: *EMC testing and measurement techniques*, of technical committee 77.

No technical changes, only editorial amendments, have been made with this transfer and reference to IEC 60801-2 (1991) or IEC 61000-4-2 is equivalent.

This consolidated version of IEC 61000-4-2 is based on the first edition (1995) [documents 77B(CO)21 and 77B/145/RVD], its amendment 1 (1998) [documents 77B/216/FDIS and 77B/226/RVD] and amendment 2 (2000) [documents 77B/291+292/FDIS and 77B/298+299/RVD].

It bears the edition number 1.2.

A vertical line in the margin shows where the base publication has been modified by amendments 1 and 2.

Annexes A and B are for information only.

The committee has decided that the contents of the base publication and its amendments will remain unchanged until 2003. At this date, the publication will be

- reconfirmed;
- withdrawn;
- replaced by a revised edition, or
- amended.

## INTRODUCTION

IEC 61000-4 is a part of the IEC 61000 series, according to the following structure:

Part 1: General

General consideration (introduction, fundamental principles)

Definitions, terminology

Part 2: Environment

Description of the environment

Classification of the environment

Compatibility levels

Part 3: Limits

Emission limits

Immunity limits (in so far as they do not fall under the responsibility of the product committees)

Part 4: Testing and measurement techniques

Measurement techniques

Testing techniques

Part 5: Installation and mitigation guidelines

Installation guidelines

Mitigation methods and devices

Part 9: Miscellaneous

Each part is further subdivided into sections which are to be published either as international standards or as technical reports.

These sections of IEC 61000-4 will be published in chronological order and numbered accordingly.

This section is an international standard which gives immunity requirements and test procedures related to "electrostatic discharge".

## **ELECTROMAGNETIC COMPATIBILITY (EMC) –**

### **Part 4-2: Testing and measurement techniques – Electrostatic discharge immunity test**

#### **1 Scope**

This International Standard relates to the immunity requirements and test methods for electrical and electronic equipment subjected to static electricity discharges, from operators directly, and to adjacent objects. It additionally defines ranges of test levels which relate to different environmental and installation conditions and establishes test procedures.

The object of this standard is to establish a common and reproducible basis for evaluating the performance of electrical and electronic equipment when subjected to electrostatic discharges. In addition, it includes electrostatic discharges which may occur from personnel to objects near vital equipment.

This standard defines:

- typical waveform of the discharge current;
- range of test levels;
- test equipment;
- test set-up;
- test procedure.

This standard gives specifications for test performed in "laboratories" and "post-installation tests" performed on equipment in the final installation.

This standard does not intend to specify the tests to be applied to particular apparatus or systems. Its main aim is to give a general basic reference to all concerned product committees of the IEC. The product committees (or users and manufacturers of equipment) remain responsible for the appropriate choice of the tests and the severity level to be applied to their equipment.

In order not to impede the task of coordination and standardization, the product committees or users and manufacturers are strongly recommended to consider (in their future work or revision of old standards) the adoption of the relevant immunity tests specified in this standard.

## 2 Normative references

The following normative documents contain provisions which, through reference in this text, constitute provisions of this section of IEC 61000-4. At the time of publication, the editions indicated were valid. All normative documents are subject to revision, and parties to agreements based on this section of IEC 61000-4 are encouraged to investigate the possibility of applying the most recent editions of the normative documents indicated below. Members of IEC and ISO maintain registers of currently valid International Standards.

IEC 60050(161):1990, *International Electrotechnical Vocabulary (IEV) – Chapter 161: Electromagnetic compatibility*

IEC 60068-1:1988, *Environmental testing – Part 1: General and guidance*

## 3 General

This standard relates to equipment, systems, subsystems and peripherals which may be involved in static electricity discharges owing to environmental and installation conditions, such as low relative humidity, use of low-conductivity (artificial-fibre) carpets, vinyl garments, etc., which may exist in allocations classified in standards relevant to electrical and electronic equipment (for more detailed information, see clause A.1 of annex A).

The tests described in this standard are considered to be a first step in the direction of commonly used tests for the qualitative evaluation of the performance of all electrical and electronic equipment as referred to in clause 1.

NOTE From the technical point of view the precise term for the phenomenon would be "static electricity discharge". However, the term "electrostatic discharge" (ESD) is widely used in the technical world and in technical literature. Therefore, it has been decided to retain the term ESD in the title of this standard.

## 4 Definitions

For the purpose of this section of IEC 61000-4, the following definitions and terms apply and are applicable to the restricted field of electrostatic discharge; not all of them are included in IEC 60050(161) [IEV].

### 4.1

#### **degradation (of performance)**

an undesired departure in the operational performance of any device, equipment or system from its intended performance. [IEV 161-01-19]

NOTE The term "degradation" can apply to temporary or permanent failure.

### 4.2

#### **electromagnetic compatibility (EMC)**

the ability of an equipment or system to function satisfactorily in its electromagnetic environment without introducing intolerable electromagnetic disturbances to anything in that environment. [IEV 161-01-07]



#### **4.3**

##### **antistatic material**

material exhibiting properties which minimize charge generation when rubbed against or separated from the same or other similar materials

#### **4.4**

##### **energy storage capacitor**

the capacitor of the ESD-generator representing the capacity of a human body charged to the test voltage value. This may be provided as a discrete component, or a distributed capacitance

#### **4.5**

##### **ESD**

electrostatic discharge (see 4.10)

#### **4.6**

##### **EUT**

equipment under test

#### **4.7**

##### **ground reference plane (GRP)**

a flat conductive surface whose potential is used as a common reference. [IEV 161-04-36]

#### **4.8**

##### **coupling plane**

a metal sheet or plate, to which discharges are applied to simulate electrostatic discharge to objects adjacent to the EUT. HCP: Horizontal Coupling Plane; VCP: Vertical Coupling Plane

#### **4.9**

##### **holding time**

interval of time within which the decrease of the test voltage due to leakage, prior to the discharge, is not greater than 10 %

#### **4.10**

##### **electrostatic discharge; ESD**

a transfer of electric charge between bodies of different electrostatic potential in proximity or through direct contact. [IEV 161-01-22]

#### **4.11**

##### **immunity (to a disturbance)**

the ability of a device, equipment or system to perform without degradation in the presence of an electromagnetic disturbance. [IEV 161-01-20]

#### **4.12**

##### **contact discharge method**

a method of testing, in which the electrode of the test generator is held in contact with the EUT, and the discharge actuated by the discharge switch within the generator

#### **4.13**

##### **air discharge method**

a method of testing, in which the charged electrode of the test generator is brought close to the EUT, and the discharge actuated by a spark to the EUT

#### 4.14

##### **direct application**

application of the discharge directly to the EUT

#### 4.15

##### **indirect application**

application of the discharge to a coupling plane in the vicinity of the EUT, and simulation of personnel discharge to objects which are adjacent to the EUT

### 5 Test levels

The preferential range of test levels for the ESD test is given in table 1.

Testing shall also be satisfied at the lower levels given in table 1.

Details concerning the various parameters which may influence the voltage level to which the human body may be charged are given in clause A.2 of annex A. Clause A.4 also contains examples of the application of the test levels related to environmental (installation) classes.

Contact discharge is the preferred test method. Air discharges shall be used where contact discharge cannot be applied. Voltages for each test method are given in tables 1a and 1b. The voltages shown are different for each method due to the differing methods of test. It is not intended to imply that the test severity is equivalent between test methods.

Further information is given in clauses A.3, A.4 and A.5 of annex A.

**Table 1 – Test levels**

<b>1a – Contact discharge</b>		<b>1b – Air discharge</b>	
<b>Level</b>	<b>Test voltage</b> kV	<b>Level</b>	<b>Test voltage</b> kV
1	2	1	2
2	4	2	4
3	6	3	8
4	8	4	15
x <sup>1)</sup>	Special	x <sup>1)</sup>	Special

<sup>1)</sup> "x" is an open level. The level has to be specified in the dedicated equipment specification. If higher voltages than those shown are specified, special test equipment may be needed.

## 6 Test generator

The test generator consists, in its main parts, of:

- charging resistor  $R_c$ ;
- energy-storage capacitor  $C_s$ ;
- distributed capacitance  $C_d$ ;
- discharge resistor  $R_d$ ;
- voltage indicator;
- discharge switch;
- interchangeable tips of the discharge electrode (see figure 4);
- discharge return cable;
- power supply unit.

A simplified diagram of the ESD generator is given in figure 1. Constructional details are not given.

The generator shall meet the requirements given in 6.1 and 6.2.

### 6.1 Characteristics and performance of the ESD generator

Specifications

- energy storage capacitance ( $C_s + C_d$ ): 150 pF  $\pm$  10 %;
- discharge resistance ( $R_d$ ): 330  $\Omega$   $\pm$  10 %;
- charging resistance ( $R_c$ ): between 50 M $\Omega$  and 100 M $\Omega$ ;
- output voltage (see note 1): up to 8 kV (nominal) for contact discharge;  
up to 15 kV (nominal) for air discharge;
- tolerance of the output voltage indication:  $\pm$ 5 %;
- polarity of the output voltage: positive and negative (switchable);
- holding time: at least 5 s;
- discharge, mode of operation (see note 2): single discharge (time between successive discharges at least 1 s);
- waveshape of the discharge current: see 6.2.

NOTE 1 Open circuit voltage measured at the energy storage capacitor.

NOTE 2 The generator should be able to generate at a repetition rate of at least 20 discharges per second for exploratory purposes only.

The generator shall be provided with means of preventing unintended radiated or conducted emissions, either of pulse or continuous type, so as not to disturb the EUT or auxiliary test equipment by parasitic effects.

The energy storage capacitor, the discharge resistor, and the discharge switch shall be placed as close as possible to the discharge electrode.

The dimensions of the discharge tips are given in figure 4.

For the air discharge test method the same generator is used and the discharge switch has to be closed. The generator shall be fitted with the round tip shown in figure 4.

The discharge return cable of the test generator shall be in general 2 m long, and constructed to allow the generator to meet the waveform specification. It shall be sufficiently insulated to prevent the flow of the discharge current to personnel or conducting surfaces other than via its termination, during the ESD test.

In cases where a 2 m length of the discharge return cable is insufficient, (e.g. for tall EUTs), a length not exceeding 3 m may be used, but compliance with the waveform specification shall be verified.

## 6.2 Verification of the characteristics of the ESD generator

In order to compare the test results obtained from different test generators, the characteristics shown in table 2 shall be verified using the discharge return cable to be used in the testing.

**Table 2 – Waveform parameters**

Level	Indicated voltage kV	First peak current of discharge $\pm 10\%$ A	Rise time $t_r$ with discharge switch ns	Current ( $\pm 30\%$ ) at 30 ns A	Current ( $\pm 30\%$ ) at 60 ns A
1	2	7,5	0,7 to 1	4	2
2	4	15	0,7 to 1	8	4
3	6	22,5	0,7 to 1	12	6
4	8	30	0,7 to 1	16	8

The waveform of the output current of the ESD generator during the verification procedure shall conform to figure 3.

The values of the characteristics of the discharge current shall be verified with 1 000 MHz bandwidth measuring instrumentation.

A lower bandwidth implies limitations in the measurement of rise time and amplitude of the first current peak.

For verification, the tip of the discharge electrode shall be placed in direct contact with the current-sensing transducer, and the generator operated in the contact discharge mode.

The typical arrangement for the verification of the ESD generator performance is given in figure 2. The bandwidth of the target has to be more than 1 GHz. Constructional details of a possible design for the current-sensing transducer are given in annex B.

Other arrangements that imply the use of a laboratory Faraday cage having dimensions different from those in figure 2 are allowed; separation of the Faraday cage from the target plane is also allowed, but in both cases the distance between the sensor and the grounding terminal point of the ESD generator shall be respected (1 m), as well as the layout of the discharge return cable.

The ESD generator shall be re-calibrated in defined time periods in accordance with a recognized quality assurance system.

## **7 Test set-up**

The test set-up consists of the test generator, EUT and auxiliary instrumentation necessary to perform direct and indirect application of discharges to the EUT in the following manner:

- a) contact discharge to the conductive surfaces and to coupling planes;
- b) air discharge at insulating surfaces.

Two different types of tests can be distinguished:

- type (conformance) tests performed in laboratories;
- post installation tests performed on equipment in its final installed conditions.

The preferred test method is that of type tests performed in laboratories.

The EUT shall be arranged in accordance with the manufacturer's instructions for installation (if any).

### **7.1 Test set-up for tests performed in laboratories**

The following requirements apply to tests performed in laboratories under environmental reference conditions outlined in 8.1.

A ground reference plane shall be provided on the floor of the laboratory. It shall be a metallic sheet (copper or aluminium) of 0,25 mm minimum thickness; other metallic materials may be used but they shall have at least 0,65 mm minimum thickness.

The minimum size of the reference plane is 1 m<sup>2</sup>, the exact size depending on the dimensions of the EUT. It shall project beyond the EUT or coupling plane by at least 0,5 m on all sides, and shall be connected to the protective grounding system.

Local safety regulations shall always be met.

The EUT shall be arranged and connected according to its functional requirements.

A distance of 1 m minimum shall be provided between the equipment under test and the walls of the laboratory and any other metallic structure.

The EUT shall be connected to the grounding system, in accordance with its installation specifications. No additional grounding connections are allowed.

The positioning of the power and signal cables shall be representative of installation practice.

The discharge return cable of the ESD generator shall be connected to the ground reference plane. The total length of this cable is in general 2 m.

In cases where this length exceeds the length necessary to apply the discharges to be selected points, the excess length shall, where possible, be placed non-inductively off the ground reference plane and shall not come closer than 0,2 m to other conductive parts in the test set-up.

The connection of the earth cables to the ground reference plane and all bondings shall be of low impedance, for example by using clamping devices for high frequency applications.

Where coupling planes are specified, for example to allow indirect application of the discharge, they shall be constructed from the same material type and thickness as that of the ground reference plane, and shall be connected to the GRP via a cable with a 470 k $\Omega$  resistor located at each end. These resistors shall be capable of withstanding the discharge voltage and shall be insulated to avoid short circuits to the GRP when the cable lies on the GRP.

Additional specifications for the different types of equipment are given below.

#### **7.1.1 Table-top equipment**

The test set-up shall consist of a wooden table, 0,8 m high, standing on the ground reference plane.

A horizontal coupling plane (HCP), 1,6 m  $\times$  0,8 m, shall be placed on the table. The EUT and cables shall be isolated from the coupling plane by an insulating support 0,5 mm thick.

If the EUT is too large to be located 0,1 m minimum from all sides of the HCP, an additional, identical HCP shall be used, placed 0,3 m from the first, with the short sides adjacent. The table has to be enlarged or two tables may be used. The HCPs shall not be bonded together, other than via resistive cables to the GRP.

Any mounting feet associated with the EUT shall remain in place.

An example of the test set-up for table-top equipment is given in figure 5.

#### **7.1.2 Floor-standing equipment**

The EUT and cables shall be isolated from the ground reference plane by an insulating support about 0,1 m thick.

An example of the test set-up for floor-standing equipment is given in figure 6.

Any mounting feet associated with the EUT shall remain in place.

### 7.1.3 Test method for ungrounded equipment

The test method described in this subclause is applicable to equipment or part(s) of equipment whose installation specifications or design preclude connection to any grounding system. Equipment, or parts thereof, includes portable, battery-operated and double-insulated equipment (class II equipment).

*Rationale:* Ungrounded equipment, or ungrounded part(s) of equipment, cannot discharge itself similarly to class I mains-supplied equipment. If the charge is not removed before the next ESD pulse is applied, it is possible that the EUT or part(s) of the EUT be stressed up to twice the intended test voltage. Therefore, double-insulated equipment could be charged at an unrealistically high charge, by accumulating several ESD discharges on the capacitance of the class II insulation, and then discharge at the breakdown voltage of the insulation with a much higher energy.

The general test set-up shall be identical to the ones described in 7.1.1 and 7.1.2 respectively.

To simulate a single ESD event (either by air or by contact discharge), the charge on the EUT shall be removed prior to each applied ESD pulse.

The charge on the metallic point or part to which the ESD pulse is to be applied, for example, connector shells, battery charge pins, metallic antennae, shall be removed prior to each applied ESD test pulse.

When one or several metallic accessible parts are subject to the ESD test, the charge shall be removed from the point where the ESD pulse is to be applied, as no guarantee can be given about the resistance between this and other accessible points on the product.

A cable with 470 k $\Omega$  bleeder resistors, similar to the one used with the horizontal and vertical coupling planes, shall be used; see 7.1.

As the capacitance between EUT and HCP (table-top) and between EUT and GRP (floor-standing) is determined by the size of the EUT, the cable with bleeder resistors may remain installed during the ESD test when functionally allowed. In the discharge cable, one resistor shall be connected as close as possible, preferably less than 20 mm from the EUT test point. The second resistor shall be connected near the end of the cable attached to the HCP for table-top equipment (see figure 8), or GRP for floor-standing equipment (see figure 9).

The presence of the cable with the bleeder resistors can influence the test results of some equipment. In case of dispute, a test with the cable disconnected during the ESD pulse takes precedence over the test with the cable installed during the test, provided that the charge has sufficiently decayed between the successive discharges.

As an alternative, the following options can be used:

- the time interval between successive discharges shall be extended to the time necessary to allow natural decay of the charge from the EUT;
- a carbon fibre brush with bleeder resistors (for example, 2 × 470 k $\Omega$ ) in the grounding cable;
- an air-ionizer to speed-up the "natural" discharging process of the EUT to its environment.

The ionizer shall be turned off when applying an air-discharge test. The use of any alternative method shall be reported in the test report.

NOTE In case of dispute concerning the charge decay, the charge on the EUT can be monitored by a non-contacting electric field meter. When the charge has decayed below 10 % of the initial value, the EUT is considered to be discharged.

The tip of the ESD generator shall be held normal (perpendicular) to the surface of the EUT.

#### **7.1.3.1 Table-top equipment**

For table-top equipment, the EUT is placed on the horizontal coupling plane on top of the insulating foil (0,5 mm thick), as described in 7.1.1 and figure 5.

When a metallic accessible part, to which the ESD pulse is to be applied, is available on the EUT, this part shall be connected to the HCP via the cable with bleeder resistors; see figure 8.

#### **7.1.3.2 Floor-standing equipment**

Floor-standing equipment without any metallic connection to the ground reference plane shall be installed similarly to 7.1.2 and figure 6.

A cable with bleeder resistors shall be used between the metallic accessible part, to which the ESD pulse is to be applied, and the ground reference plane (GRP); see figure 9.

### **7.2 Test set-up for post-installation tests**

These tests are optional, and not mandatory for certification tests; they may be applied only when agreed between manufacturer and customer. It has to be considered that other co-located equipment may be unacceptably affected.

The equipment or system shall be tested in its final installed conditions.

In order to facilitate a connection for the discharge return cable, a ground reference plane shall be placed on the floor of the installation, close to the EUT at about 0,1 m distance. This plane should be of copper or aluminium not less than 0,25 mm thick. Other metallic materials may be used, providing the minimum thickness is 0,65 mm. The plane should be approximately 0,3 m wide, and 2 m in length where the installation allows.

This ground reference plane should be connected to the protective earthing system. Where this is not possible, it should be connected to the earthing terminal of the EUT, if available.

The discharge return cable of the ESD generator shall be connected to the reference plane at a point close to the EUT. Where the EUT is installed on a metal table, the table shall be connected to the reference plane via a cable with a 470 k $\Omega$  resistor located at each end, to prevent a build-up of charge.

An example of the set-up for post-installation tests is given in figure 7.



## **8 Test procedure**

### **8.1 Laboratory reference conditions**

In order to minimize the impact of environmental parameters on test results, the tests shall be carried out in climatic and electromagnetic reference conditions as specified in 8.1.1 and 8.1.2.

#### **8.1.1 Climatic conditions**

In the case of air discharge testing, the climatic conditions shall be within the following ranges:

- ambient temperature: 15 °C to 35 °C;
- relative humidity: 30 % to 60 %;
- atmospheric pressure: 86 kPa (860 mbar) to 106 kPa (1 060 mbar).

NOTE Any other values are specified in the product specification.

The EUT shall be operated within its intended climatic conditions.

#### **8.1.2 Electromagnetic conditions**

The electromagnetic environment of the laboratory shall not influence the test results.

### **8.2 EUT exercising**

The test programs and software shall be chosen so as to exercise all normal modes of operation of the EUT. The use of special exercising software is encouraged, but permitted only where it can be shown that the EUT is being comprehensively exercised.

For conformance testing, the EUT shall be continually operated in its most sensitive mode (program cycle) which shall be determined by preliminary testing.

If monitoring equipment is required, it should be decoupled in order to reduce the possibility of erroneous failure indication.

### **8.3 Execution of the test**

The testing shall be performed by direct and indirect application of discharges to the EUT according to a test plan. This should include:

- representative operating conditions of the EUT;
- whether the EUT should be tested as table-top or floor-standing;
- the points at which discharges are to be applied;
- at each point, whether contact or air discharges are to be applied;
- the test level to be applied;
- the number of discharges to be applied at each point for compliance testing;
- whether post-installation tests are also to be applied.

It may be necessary to carry out some investigatory testing to establish some aspects of the test plan.

### 8.3.1 Direct application of discharges to the EUT

Unless stated otherwise in the generic, product-related or product-family standards, the static electricity discharges shall be applied only to those points and surfaces of the EUT which are accessible to persons during normal use. The following exclusions apply (i.e. discharges are not applied to those items):

- a) those points and surfaces which are only accessible under maintenance. In this case, special ESD mitigation procedures shall be given in the accompanying documentation;
- b) those points and surfaces which are only accessible under service by the (end-)user. Examples of these rarely accessed points are as follows: battery contacts while changing batteries, a cassette in a telephone answering machine, etc.;
- c) those points and surfaces of equipment which are no longer accessible after fixed installation or after following the instructions for use, for example, the bottom and/or wall-side of equipment or areas behind fitted connectors;
- d) the contacts of coaxial and multi-pin connectors which are provided with a metallic connector shell. In this case, contact discharges shall only be applied to the metallic shell of that connector.

Contacts within a non-conductive (for example, plastic) connector and which are accessible shall be tested by the air-discharge test only. This test shall be carried out by using the rounded tip finger on the ESD generator.

In general, six cases shall be considered:

Case	Connector shell	Cover material	Air discharge to:	Contact discharge to:
1	Metallic	None	–	Shell
2	Metallic	Insulated	Cover	Shell when accessible
3	Metallic	Metallic	–	Shell and cover
4	Insulated	None	a	–
5	Insulated	Insulated	Cover	–
6	Insulated	Metallic	–	Cover

NOTE In case a cover is applied to provide (ESD) shielding to the connector pins, an ESD warning label should be present on that cover or on the equipment near to that connector to which the cover is applied.

<sup>a</sup> If the product (family) standard requires testing to individual pins of an insulated connector, air discharges shall apply.

- e) those contacts of connectors or other accessible parts that are ESD sensitive because of functional reasons and are provided with an ESD warning label, for example, r.f. inputs from measurement, receiving or other communication functions.

*Rationale:* Many connector ports are designed to handle high-frequency information, either analogue or digital, and therefore cannot be provided with sufficient overvoltage protection devices. In the case of analogue signals, bandpass filters may be a solution. Overvoltage protecting diodes have too much stray capacitance to be useful at the frequencies at which the EUT is designed to operate.

In all previous cases, special ESD mitigation procedures are recommended, to be given in the accompanying documentation.

The test voltage shall be increased from the minimum to the selected test level, in order to determine any threshold of failure (see clause 5). The final test level should not exceed the product specification value in order to avoid damage to the equipment.

The test shall be performed with single discharges. On preselected points at least ten single discharges (in the most sensitive polarity) shall be applied.

For the time interval between successive single discharges an initial value of 1 s is recommended. Longer intervals may be necessary to determine whether a system failure has occurred.

NOTE The points to which the discharges should be applied may be selected by means of an exploration carried out at a repetition rate of 20 discharges per second, or more.

The ESD generator shall be held perpendicular to the surface to which the discharge is applied. This improves repeatability of the test results.

The discharge return cable of the generator shall be kept at a distance of at least 0,2 m from the EUT whilst the discharge is being applied.

*In the case of contact discharges*, the tip of the discharge electrode shall touch the EUT, before the discharge switch is operated.

In the case of painted surfaces covering a conducting substrate, the following procedure shall be adopted:

If the coating is not declared to be an insulating coating by the equipment manufacturer, then the pointed tip of the generator shall penetrate the coating so as to make contact with the conducting substrate. Coating declared as insulating by the manufacturer shall only be submitted to the air discharge. The contact discharge test shall not be applied to such surfaces.

*In the case of air discharges*, the round discharge tip of the discharge electrode shall be approached as fast as possible (without causing mechanical damage) to touch the EUT. After each discharge, the ESD generator (discharge electrode) shall be removed from the EUT. The generator is then retriggered for a new single discharge. This procedure shall be repeated until the discharges are completed. In the case of an air discharge test, the discharge switch, which is used for contact discharge, shall be closed.

### **8.3.2 Indirect application of the discharge**

Discharges to objects placed or installed near the EUT shall be simulated by applying the discharges of the ESD generator to a coupling plane, in the contact discharge mode.

In addition to the test procedure described in 8.3.1, the requirements given in 8.3.2.1 and 8.3.2.2 shall be met.

### **8.3.2.1 Horizontal coupling plane (HCP) under the EUT**

Discharge to the HCP shall be made horizontally to the edge of the HCP.

At least 10 single discharges (in the most sensitive polarity) shall be applied at the front edge of each HCP opposite the centre point of each unit (if applicable) of the EUT and 0,1 m from the front of the EUT. The long axis of the discharge electrode shall be in the plane of the HCP and perpendicular to its front edge during the discharge.

The discharge electrode shall be in contact with the edge of the HCP (see figure 5).

In addition, consideration should be given to exposing all sides of the EUT to this test.

### **8.3.2.2 Vertical coupling plane**

At least 10 single discharges (in the most sensitive polarity) shall be applied to the centre of one vertical edge of the coupling plane (figures 5 and 6). The coupling plane, of dimensions 0,5 m × 0,5 m, is placed parallel to, and positioned at a distance of 0,1 m from, the EUT.

Discharges shall be applied to the coupling plane, with sufficient different positions such that the four faces of the EUT are completely illuminated.

## **9 Evaluation of test results**

The test results shall be classified in terms of the loss of function or degradation of performance of the equipment under test, relative to a performance level defined by its manufacturer or the requestor of the test, or agreed between the manufacturer and the purchaser of the product. The recommended classification is as follows:

- a) normal performance within limits specified by the manufacturer, requestor or purchaser;
- b) temporary loss of function or degradation of performance which ceases after the disturbance ceases, and from which the equipment under test recovers its normal performance, without operator intervention;
- c) temporary loss of function or degradation of performance, the correction of which requires operator intervention;
- d) loss of function or degradation of performance which is not recoverable, owing to damage to hardware or software, or loss of data.

The manufacturer's specification may define effects on the EUT which may be considered insignificant, and therefore acceptable.

This classification may be used as a guide in formulating performance criteria, by committees responsible for generic, product and product-family standards, or as a framework for the agreement on performance criteria between the manufacturer and the purchaser, for example where no suitable generic, product or product-family standard exists.

## 10 Test report

The test report shall contain all the information necessary to reproduce the test. In particular, the following shall be recorded:

- the items specified in the test plan required by clause 8 of this standard;
- identification of the EUT and any associated equipment, for example, brand name, product type, serial number;
- identification of the test equipment, for example, brand name, product type, serial number;
- any special environmental conditions in which the test was performed, for example, shielded enclosure;
- any specific conditions necessary to enable the test to be performed;
- performance level defined by the manufacturer, requestor or purchaser;
- performance criterion specified in the generic, product or product-family standard;
- any effects on the EUT observed during or after the application of the test disturbance, and the duration for which these effects persist;
- the rationale for the pass/fail decision (based on the performance criterion specified in the generic, product or product-family standard, or agreed between the manufacturer and the purchaser);
- any specific conditions of use, for example cable length or type, shielding or grounding, or EUT operating conditions, which are required to achieve compliance.

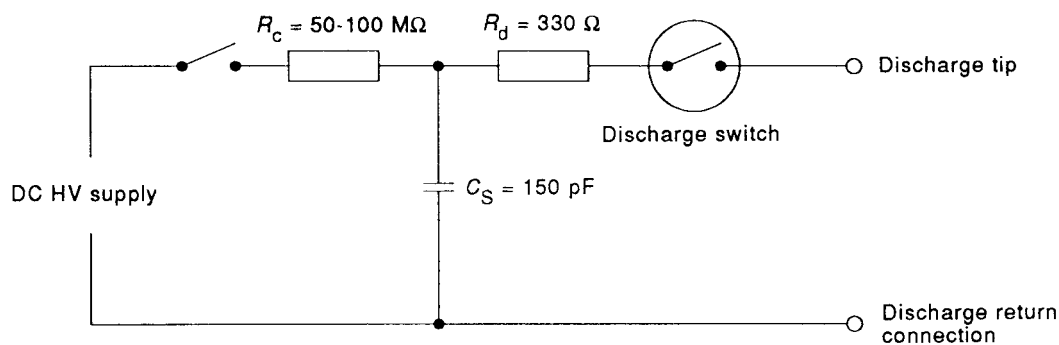

IEC 00195

NOTE  $C_d$ , omitted in the figure, is a distributed capacitance which exists between the generator and the EUT, GRP, and coupling planes. Because the capacitance is distributed over the whole of the generator, it is not possible to show this in the circuit.

Figure 1 – Simplified diagram of the ESD generator

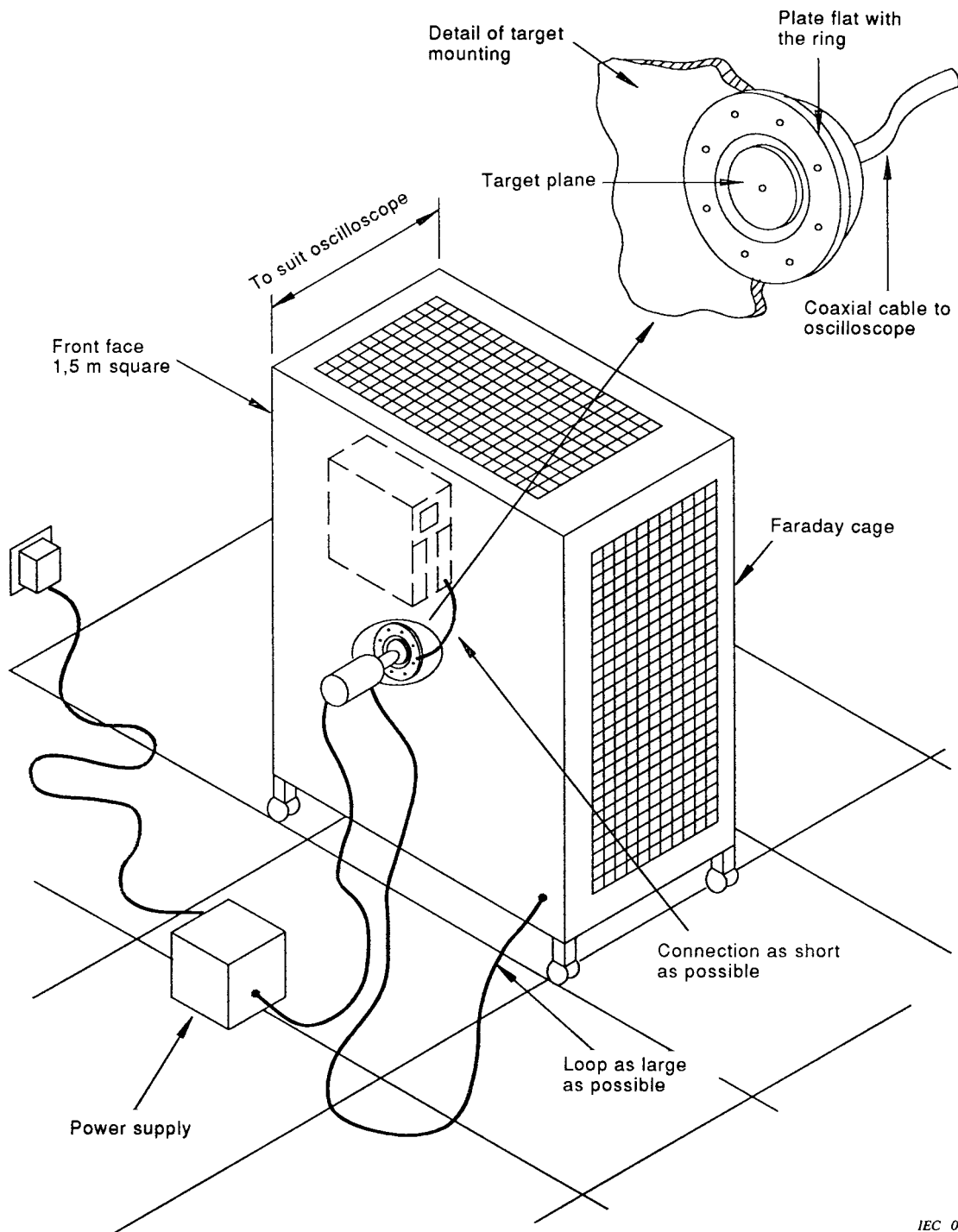
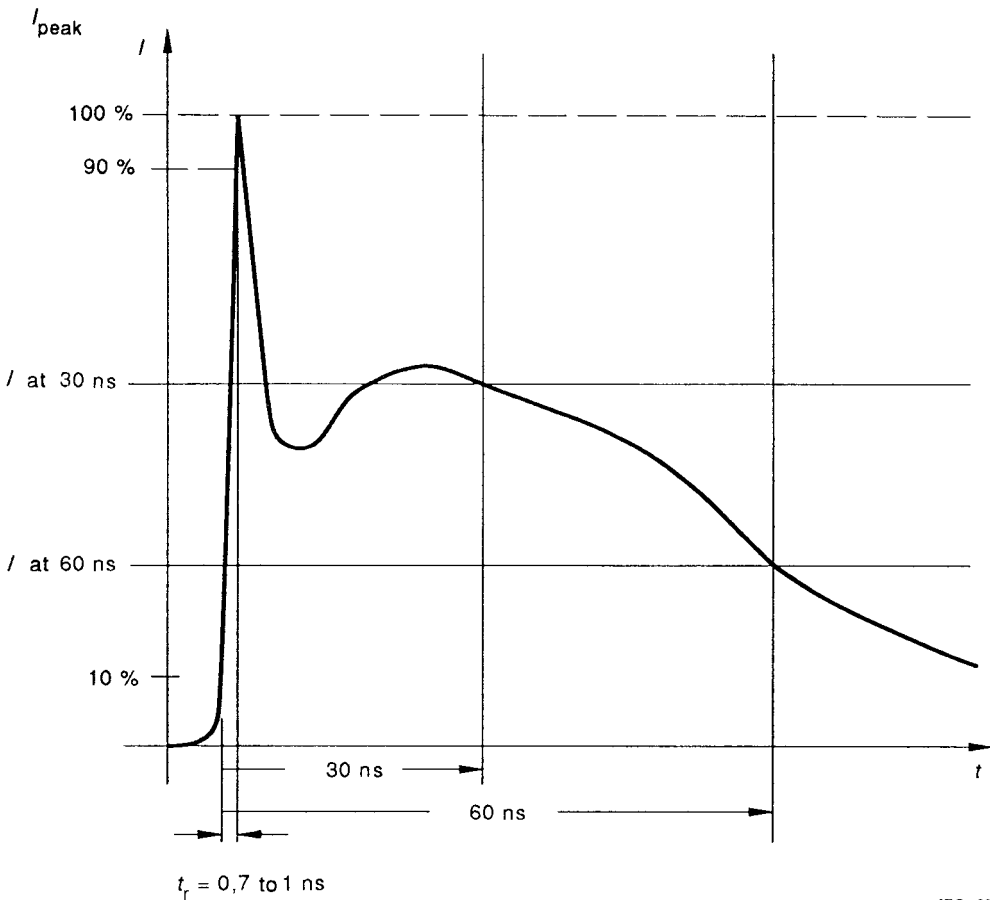

Figure 2 – Example of arrangement for verification of the ESD generator



IEC 003195

Values are given in table 2.

Figure 3 – Typical waveform of the output current of the ESD generator

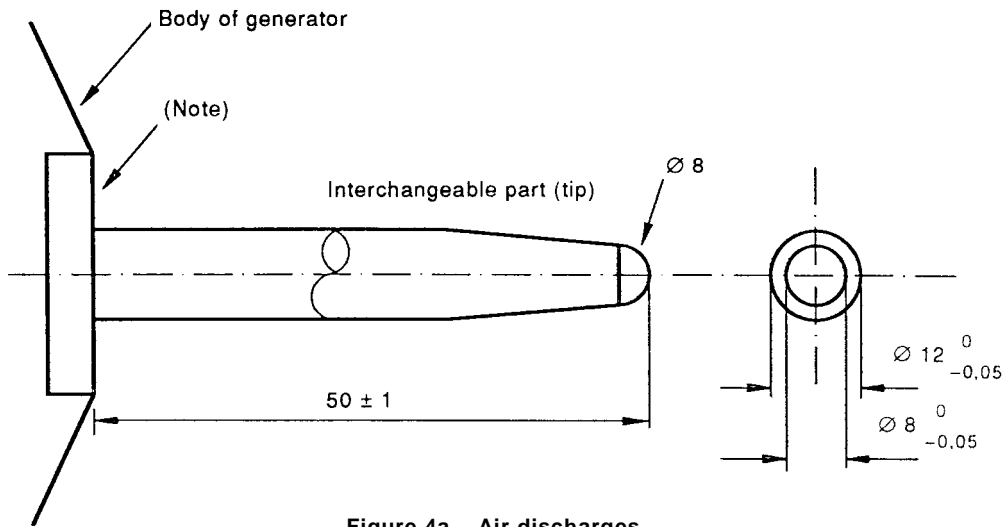

Figure 4a – Air discharges

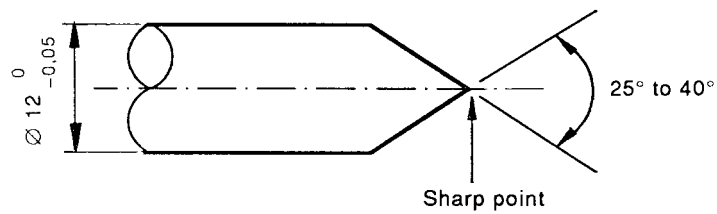

Figure 4b – Contact discharges

IEC 004/95

*Dimensions in millimetres*

NOTE The discharge switch (e.g. vacuum relay) shall be mounted as close as possible to the tip of the discharge electrode.

Figure 4 – Discharge electrodes of the ESD generator



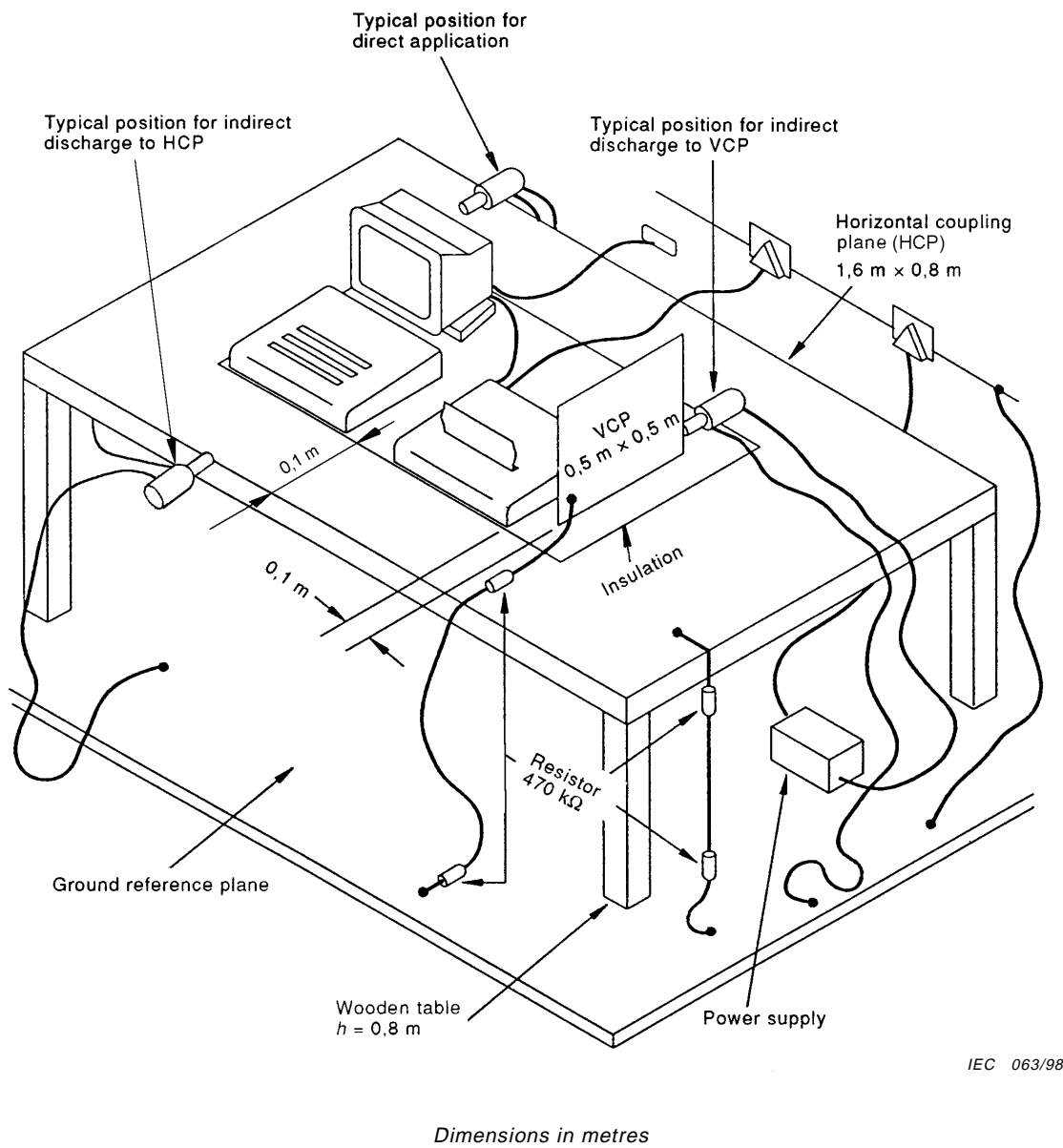

**Figure 5 – Example of test set-up for table-top equipment –  
Laboratory tests**

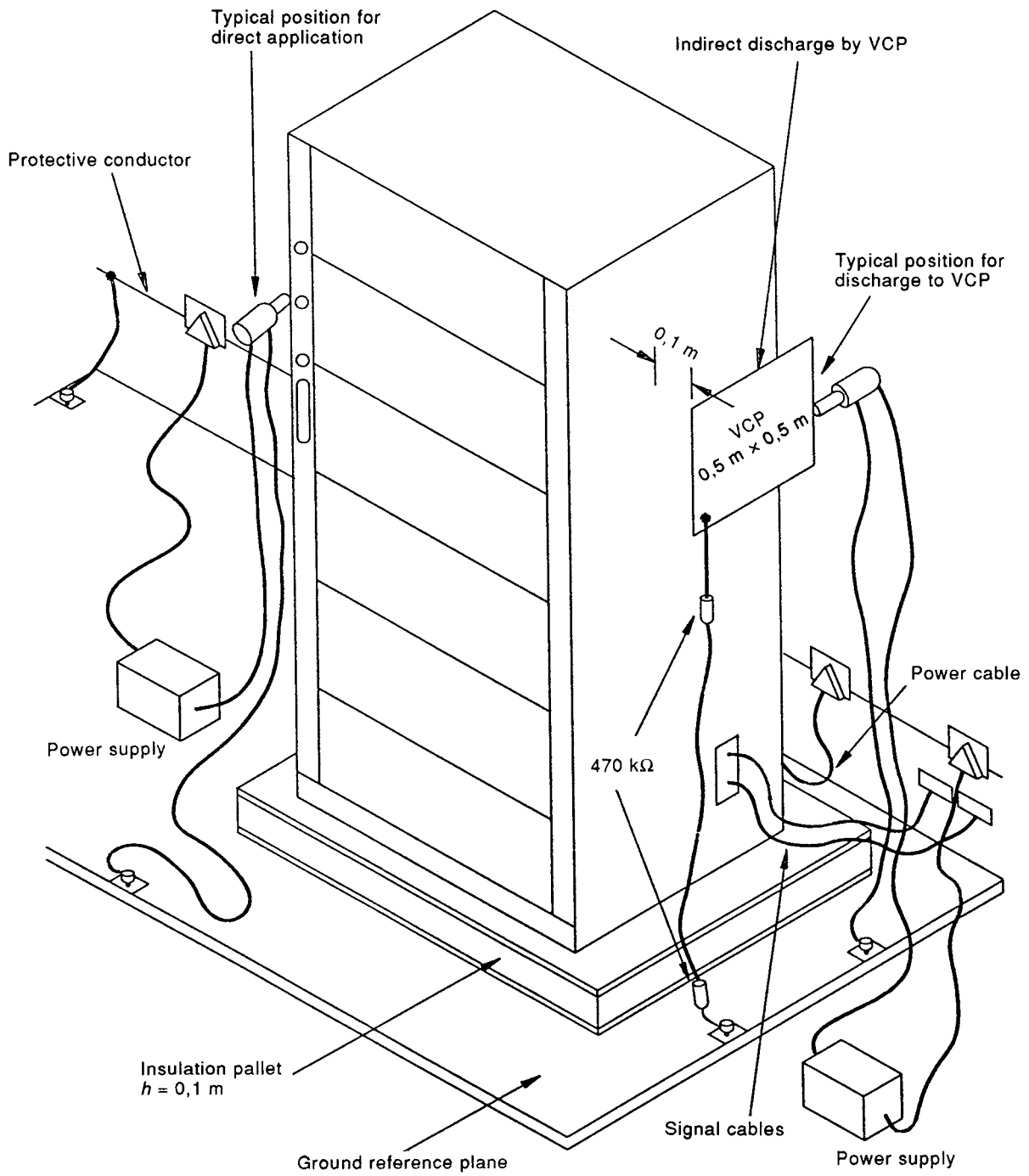
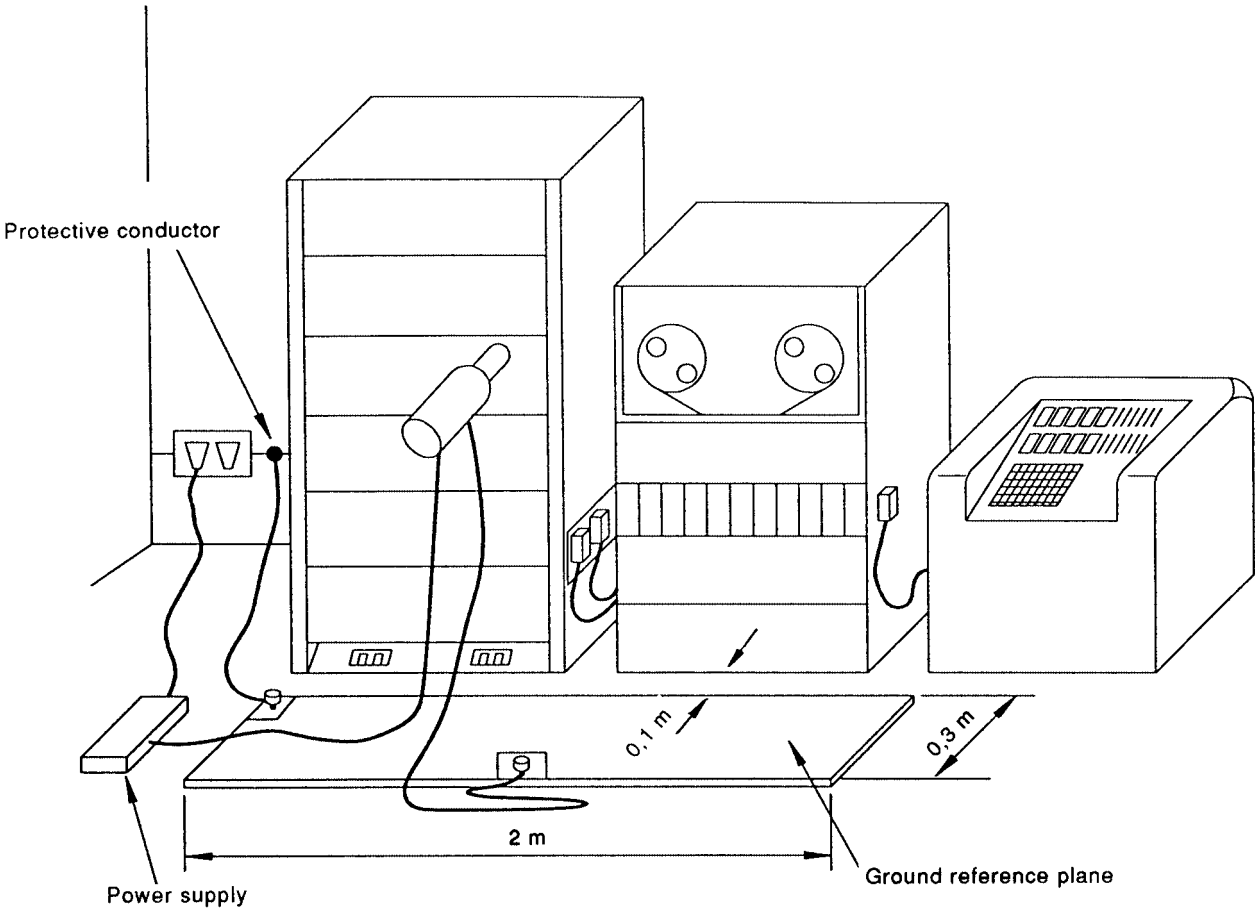
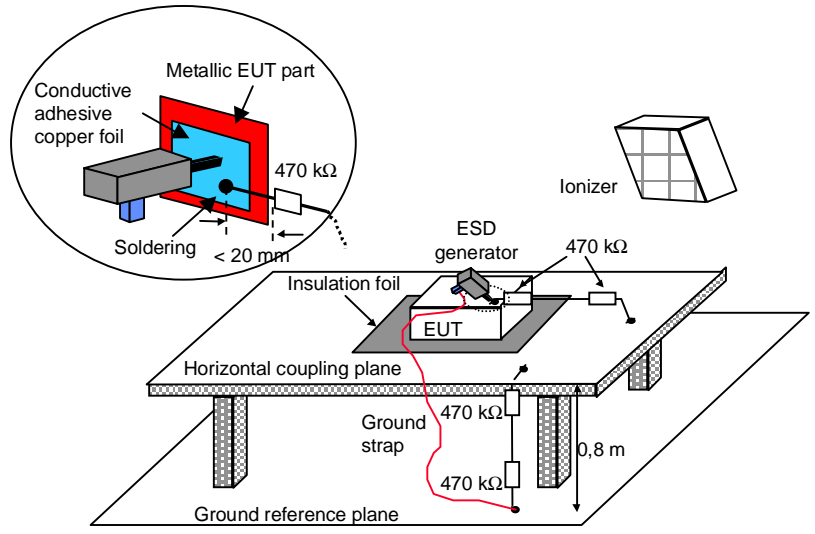

Figure 6 – Example of test set-up for floor-standing equipment, laboratory tests



IEC 007195

Figure 7 – Example of test set-up for floor-standing equipment, post-installation tests



IE 1807/2000

Figure 8 – Test set-up for ungrounded table-top equipment

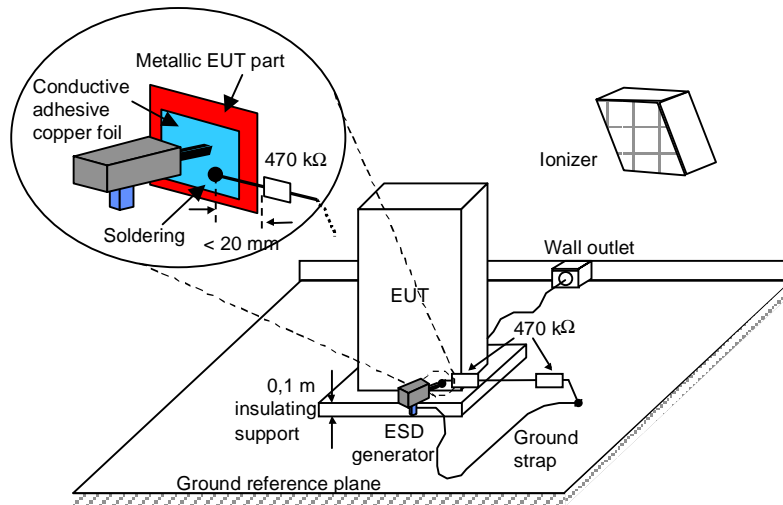

IEC 1808/2000

Figure 9 – Test set-up for ungrounded floor-standing equipment

## **Annex A** (informative)

### **Explanatory notes**

#### **A.1 General considerations**

The problem of protecting equipment against the discharge of static electricity has gained considerable importance for manufacturers and users.

The extensive use of microelectronic components has emphasized the need to define the aspects of the problem and to seek a solution in order to enhance products/system reliability.

The problem of static electricity accumulation and subsequent discharges becomes more relevant for uncontrolled environments and the widespread application of equipment and systems in a wide range of industrial plants.

Equipment may also be subjected to electromagnetic energies whenever discharges occur from personnel to nearby objects. Additionally, discharges can occur between metal objects, such as chairs and tables, in the proximity of equipment. However, based on limited experience available to date, it is considered that the tests described in this standard may adequately simulate the effects of the latter phenomenon. This aspect will be investigated and may lead to an amendment of this standard.

The effects of the operator discharge may be a simple malfunction of the equipment or damage of electronic components. The dominant effects can be attributed to the parameters of the discharge current (rise time, duration, etc.).

The knowledge of the problem and the necessity to have a tool to assist in the prevention of undesirable effects due to the discharge of static electricity on equipment, have initiated the development of the standard testing procedure described in this standard.

#### **A.2 Influences of the environmental conditions on the levels of charge**

The generation of electrostatic charges is especially favoured by the combination of synthetic fabrics and dry atmosphere. There are many possible variations in the charging process. A common situation is one in which an operator walks over a carpet and at each step loses or gains electrons from his body to the fabric. Friction between the operator's clothing and his chair can also produce an exchange of charges. The operator's body may be charged either directly or by electrostatic inductions; in the latter case a conducting carpet will give no protection unless the operator is adequately earthed to it.

The graphic representation of figure A.1 shows the voltage values to which different fabrics may be charged depending on the relative humidity of the atmosphere.

Equipment may be directly subjected to discharges of voltage values up to several kilovolts, depending on the type of synthetic fabric and the relative humidity of the environment.

### A.3 Relationship of environmental levels to air and contact discharge

As a measurable quantity, static voltage levels found in user environments have been applied to define immunity requirements. However, it has been shown that energy transfer is a function of the discharge current rather than, as well as, of the electrostatic voltage existing prior to the discharge. Further, it has been found that the discharge current typically is less than proportional to the pre-discharge voltage in the higher level ranges.

Possible reasons for non-proportional relationship between pre-discharge voltage and discharge current are:

- The discharge of high-voltage charges typically should occur through a long arcing path which increases the rise time, hence keeping the higher spectral components of the discharge current less than proportional to the pre-discharge voltage.
- High charge voltage levels will more likely develop across a small capacitance, assuming the amount of charge should be constant for a typical charge generation event. Conversely, high charge voltages across a large capacitance would need a number of successive generation events which is less likely to occur. This means that the charge energy tends to become constant between the higher charge voltages found in the user environment.

As a conclusion from the above, the immunity requirements for a given user environment need to be defined in terms of discharge current amplitudes.

Having recognized this concept, the design of the tester is eased. Trade-off in the choice of tester charge voltage and discharge impedance can be applied to achieve desired discharge current amplitudes.

### A.4 Selection of test levels

The test levels should be selected in accordance with the most realistic installation and environmental conditions; a guideline is given in table A.1.

**Table A.1 – Guideline for the selection of the test levels**

Class	Relative humidity as low as	Antistatic material	Synthetic material	Maximum voltage
	%			kV
1	35	x		2
2	10	x		4
3	50		x	8
4	10		x	15

The installation and environmental classes recommended are related to the test levels outlined in clause 5 of this standard.

For some materials, for example wood, concrete and ceramic, the probable level is not greater than level 2.

NOTE It is important, when considering the selection of an appropriate test level for a particular environment, to understand the critical parameters of the ESD effect.

The most critical parameter is perhaps the rate of change of discharge current which may be obtained through a variety of combinations of charging voltage, peak discharge current and rise time.

For example, the required ESD stress for the 15 kV synthetic material environment is more than adequately covered by the 8 kV/30 A class 4 test using the ESD generator contact discharge defined in this standard.

However, in a very dry environment with synthetic materials, higher voltages than 15 kV occur.

In the case of testing equipment with insulating surfaces, the air discharge method with voltages up to 15 kV may be used.

## **A.5 Selection of test points**

The test points to be considered may, for example, include the following locations as applicable:

- points on metallic sections of a cabinet which are electrically isolated from ground;
- any point in the control or keyboard area and any other point of man-machine communication, such as switches, knobs, buttons, and other operator-accessible areas;
- indicators, LEDs, slots, grilles, connector hoods, etc.

## **A.6 Technical rationale for the use of the contact discharge method**

In general the reproducibility of the previous test method (air discharge) was influenced by, for example, the speed of approach of the discharge tip, humidity, and construction of the test equipment, leading to variations in pulse rise time and magnitude of the discharge current.

In previous designs of ESD testers, the ESD event was simulated by discharging a charged capacitor through a discharge tip onto the EUT, the discharge tip forming a spark gap at the surface of the EUT.

The spark is a very complicated physical phenomenon. It has been shown that with a moving spark gap the resulting rise time (or rising slope) of the discharge current can vary from less than 1 ns and more than 20 ns, as the approach speed is varied.

Keeping the approach speed constant does not result in constant rise time. For some voltage/speed combinations, the rise time still fluctuates by a factor of up to 30.

One proposed way to stabilize the rise time is to use a mechanically fixed spark gap. Although the rise time is stabilized with this method, it cannot be recommended because the resulting rise time is much slower than the rise time of the natural event to be simulated.

The high-frequency content of the real ESD event is not properly simulated with this method. Using various types of triggering devices (e.g. gas tubes or thyratrons) instead of the open spark, is another possibility, but such kinds of triggering devices produce rise times which are still too low compared to the rise times of the real ESD event.

The only triggering device known today which is able to produce repeatable and fast rising discharge currents is the relay. The relay should have sufficient voltage capability and a single contact (to avoid double discharges in the rising part). For higher voltages, vacuum relays prove to be useful. Experience shows that by using a relay as the triggering device, not only the measured discharge pulse shape is much more repeatable in its rising part, but also the test results with real EUTs are more reproducible.

Consequently the relay-driven impulse tester is a device that produces a specified current pulse (amplitude and rise time).

This current is related to the real ESD voltage, as described in clause A.3.

#### **A.7 Selection of elements for the ESD generator**

A storage capacitance shall be used which is representative of the capacitance of the human body. A nominal value of 150 pF has been determined suitable for this purpose.

A resistance of 330  $\Omega$  has been chosen to represent the source resistance of a human body holding a metallic object such as a key or tool. It has been shown that this metal discharge situation is sufficiently severe to represent all human discharges in the field.



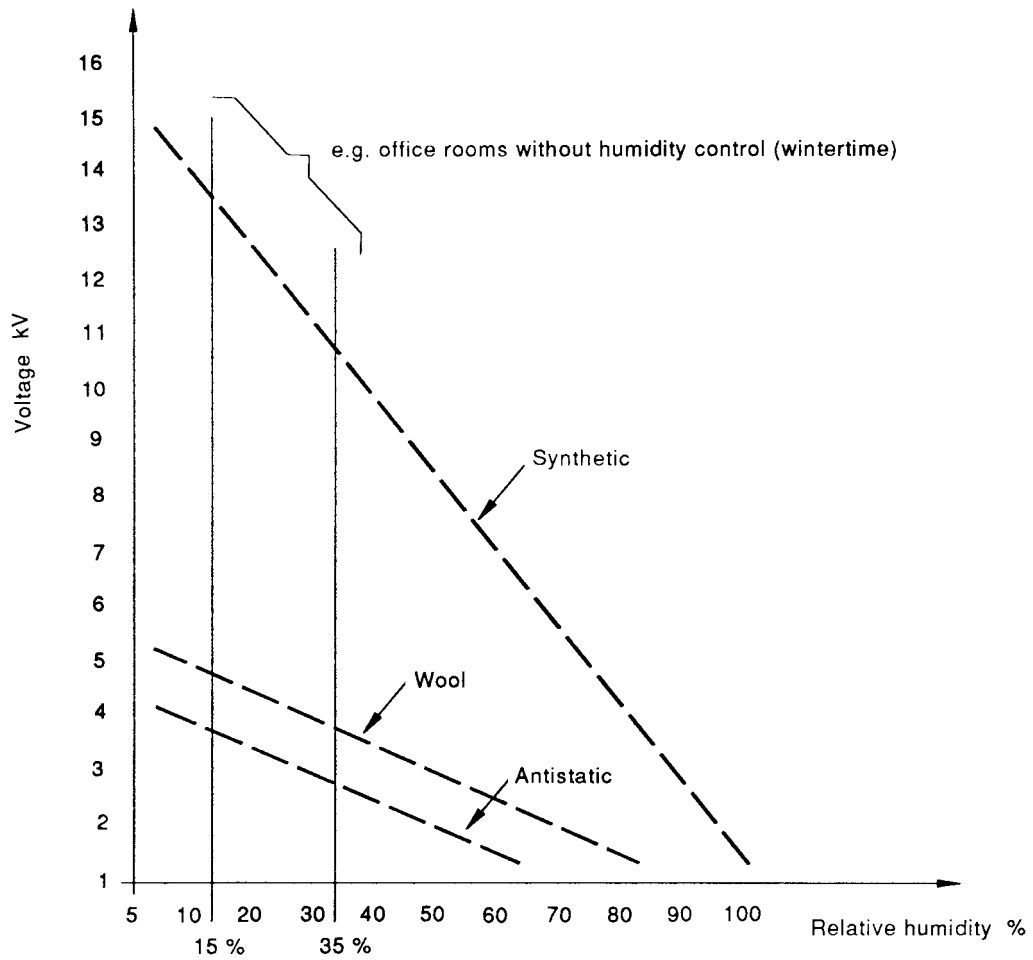

IEC 008/95

**Figure A.1 – Maximum values of electrostatic voltages to which operators may be charged while in contact with the materials mentioned in clause A.2**

## **Annex B** (informative)

### **Constructional details**

#### **B.1 Current-sensing transducer**

The constructional details for a possible current-sensing transducer are shown in the figures B.1 to B.7.

The following sequence of assembly should be followed:

- 1) Solder the 25 load resistors "7" ( $51 \Omega$ , 5 %, 0,25 W) onto the output side disc "3" and shave the soldered terminals.
- 2) Solder the 5 matching resistors "8" ( $240 \Omega$ , 5 %, 0,25 W) in a pentagonal disposition onto the output connector, of Type N coaxial construction.
- 3) Assemble the output side disc "3", complete with load resistors, onto the output connector flange "1" using 4 screws M2,5 Pan Hd 6,5 mm long.
- 4) Assemble the output connector complete with matching resistors, "7" onto the output connector flange "1" using 4 screws M3.
- 5) Solder the input disc "4", with the screw support for electrode "6" screwed and soldered, on both the load and matching resistors group. Shave the soldered terminals.
- 6) Screw the flat electrode disc "5" on the screw support for electrode "6", then assemble the support for fixing "2" using 8 screws M3 Pan Hd 6,5 mm long.

#### **B.2 Inductive current probe**

Description and constructional details are under consideration.

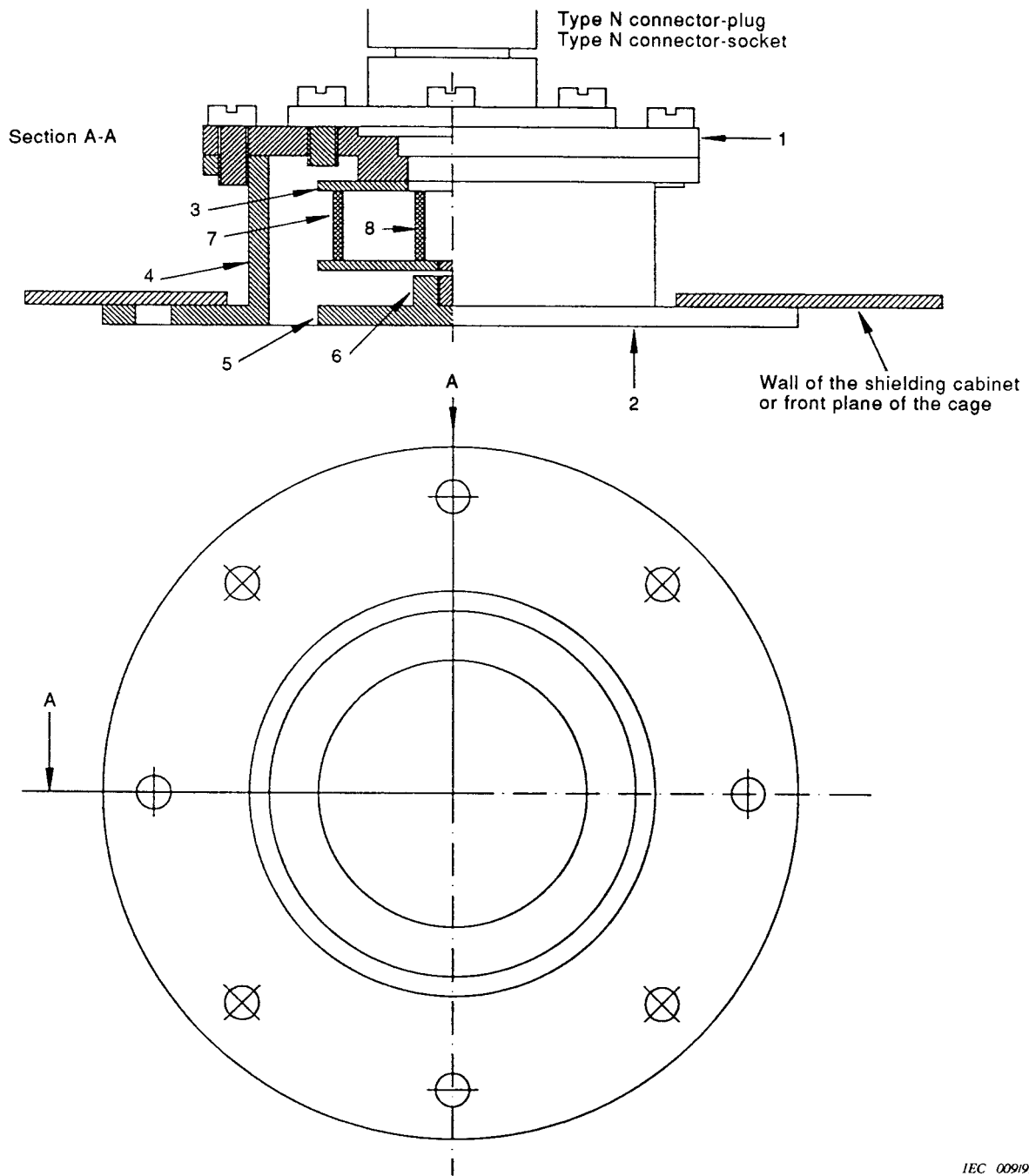

IEC 009195

Item	Qty	Screws	QTY
1	1	M3 PAN HD SC × 6,5 mm LG	12
2	1		
3	1		
4	1		
5	1	M2,5 PAN HD SC × 5,0 mm LG	3
6	1		
7	25	Resistor 51 Ω	
8	5	Resistor 240 Ω	

Figure B.1 – Construction details of the resistive load

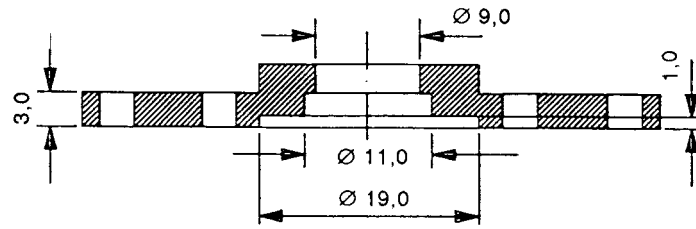

Section A-A

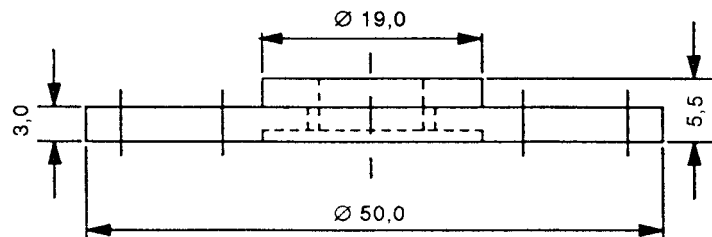
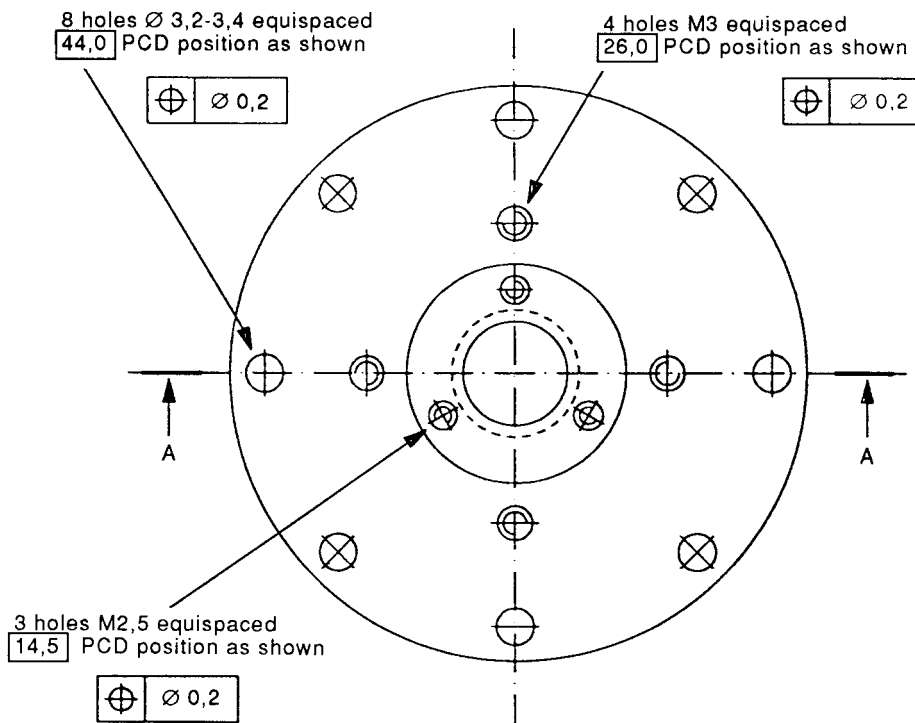

IEC 01095

Dimensions in millimetres

Material and finish: silver-plated copper or silver-plated brass

Figure B.2

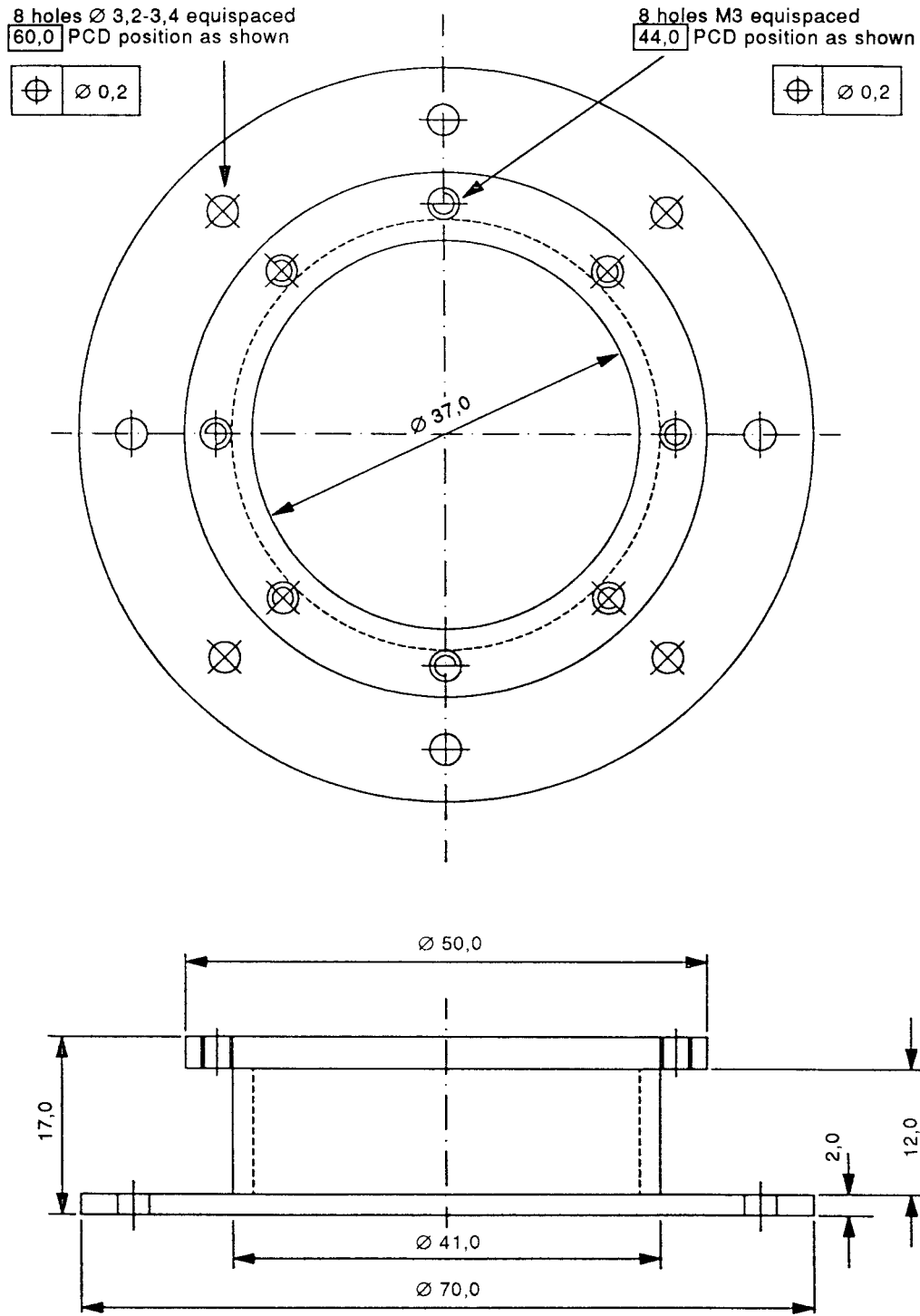

IEC 01195

Dimensions in millimetres

Material and finish: silver-plated copper or silver-plated brass

Figure B.3

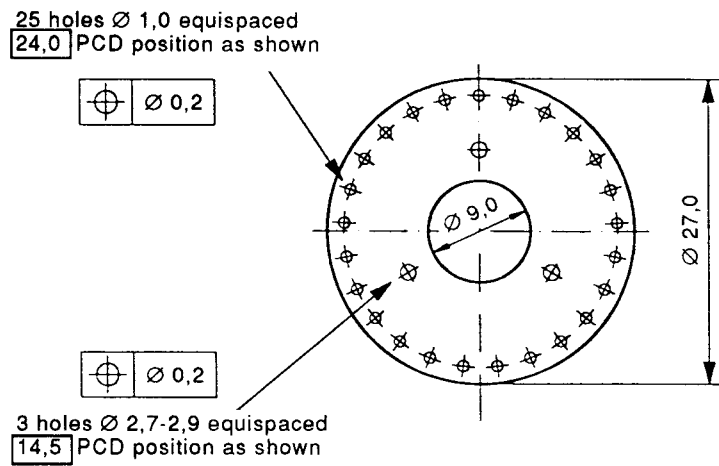

IEC 012/95

Dimensions in millimetres

Material and finish: silver-plated copper or silver-plated brass 1 mm thick

Figure B.4

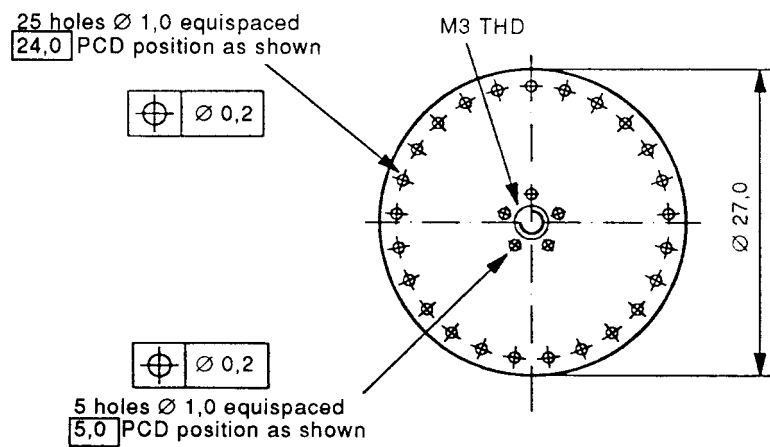

IEC 013/95

Dimensions in millimetres

Material and finish: silver-plated copper or silver-plated brass 1 mm thick

Figure B.5

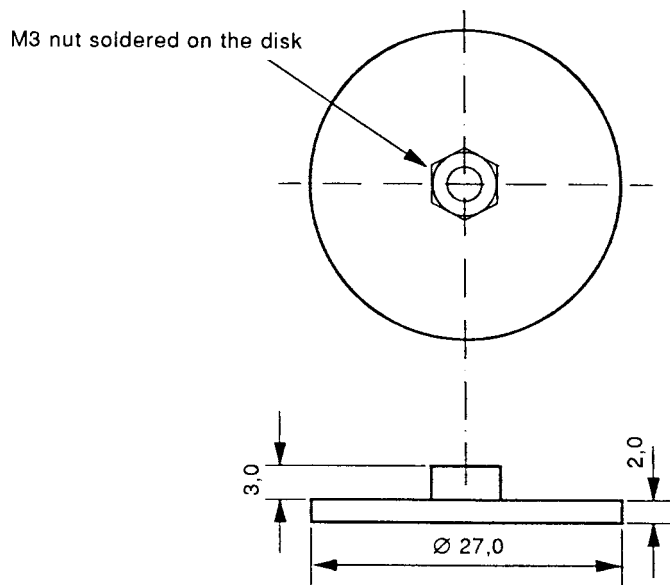

IEC 014195

Dimensions in millimetres

Material and finish: silver-plated copper or silver-plated brass

Figure B.6

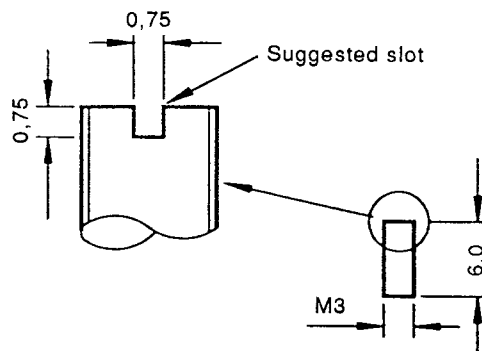

IEC 015195

Dimensions in millimetres

Material and finish: silver-plated copper or silver-plated brass

Figure B.7



## Standards Survey

The IEC would like to offer you the best quality standards possible. To make sure that we continue to meet your needs, your feedback is essential. Would you please take a minute to answer the questions overleaf and fax them to us at +41 22 919 03 00 or mail them to the address below. Thank you!

Customer Service Centre (CSC)

**International Electrotechnical Commission**

3, rue de Varembé  
1211 Genève 20  
Switzerland

or

Fax to: **IEC/CSC** at +41 22 919 03 00

Thank you for your contribution to the standards-making process.

**A Prioritaire**

Nicht frankieren  
Ne pas affranchir



Non affrancare  
No stamp required

**RÉPONSE PAYÉE**

**SUISSE**

Customer Service Centre (CSC)  
**International Electrotechnical Commission**  
3, rue de Varembé  
1211 GENEVA 20  
Switzerland







Enquête sur les normes

La CEI ambitionne de vous offrir les meilleures normes possibles. Pour nous assurer que nous continuons à répondre à votre attente, nous avons besoin de quelques renseignements de votre part. Nous vous demandons simplement de consacrer un instant pour répondre au questionnaire ci-après et de nous le retourner par fax au +41 22 919 03 00 ou par courrier à l'adresse ci-dessous. Merci !

Centre du Service Clientèle (CSC)

**Commission Electrotechnique Internationale**

3, rue de Varembé

1211 Genève 20

Suisse

ou

Télécopie: **CEI/CSC** +41 22 919 03 00

Nous vous remercions de la contribution que vous voudrez bien apporter ainsi à la Normalisation Internationale.

**A Prioritaire**

Nicht frankieren  
Ne pas affranchir



Non affrancare  
No stamp required

**RÉPONSE PAYÉE**

**SUISSE**

Centre du Service Clientèle (CSC)

**Commission Electrotechnique Internationale**

3, rue de Varembé

1211 GENÈVE 20

Suisse





## 射频和天线设计培训课程推荐

易迪拓培训([www.edatop.com](http://www.edatop.com))由数名来自于研发第一线的资深工程师发起成立,致力并专注于微波、射频、天线设计研发人才的培养;我们于 2006 年整合合并微波 EDA 网([www.mweda.com](http://www.mweda.com)),现已发展成为国内最大的微波射频和天线设计人才培养基地,成功推出多套微波射频以及天线设计经典培训课程和 ADS、HFSS 等专业软件使用培训课程,广受客户好评;并先后与人民邮电出版社、电子工业出版社合作出版了多本专业图书,帮助数万名工程师提升了专业技术能力。客户遍布中兴通讯、研通高频、埃威航电、国人通信等多家国内知名公司,以及台湾工业技术研究院、永业科技、全一电子等多家台湾地区企业。

易迪拓培训课程列表: <http://www.edatop.com/peixun/rfe/129.html>



### 射频工程师养成培训课程套装

该套装精选了射频专业基础培训课程、射频仿真设计培训课程和射频电路测量培训课程三个类别共 30 门视频培训课程和 3 本图书教材;旨在引领学员全面学习一个射频工程师需要熟悉、理解和掌握的专业知识和研发设计能力。通过套装的学习,能够让学员完全达到和胜任一个合格的射频工程师的要求...

课程网址: <http://www.edatop.com/peixun/rfe/110.html>

### ADS 学习培训课程套装

该套装是迄今国内最全面、最权威的 ADS 培训教程,共包含 10 门 ADS 学习培训课程。课程是由具有多年 ADS 使用经验的微波射频与通信系统设计领域资深专家讲解,并多结合设计实例,由浅入深、详细而又全面地讲解了 ADS 在微波射频电路设计、通信系统设计和电磁仿真设计方面的内容。能让您在最短的时间内学会使用 ADS,迅速提升个人技术能力,把 ADS 真正应用到实际研发工作中去,成为 ADS 设计专家...



课程网址: <http://www.edatop.com/peixun/ads/13.html>



### HFSS 学习培训课程套装

该套课程套装包含了本站全部 HFSS 培训课程,是迄今国内最全面、最专业的 HFSS 培训教程套装,可以帮助您从零开始,全面深入学习 HFSS 的各项功能和在多个方面的工程应用。购买套装,更可超值赠送 3 个月免费学习答疑,随时解答您学习过程中遇到的棘手问题,让您的 HFSS 学习更加轻松顺畅...

课程网址: <http://www.edatop.com/peixun/hfss/11.html>

## CST 学习培训课程套装

该培训套装由易迪拓培训联合微波 EDA 网共同推出,是最全面、系统、专业的 CST 微波工作室培训课程套装,所有课程都由经验丰富的专家授课,视频教学,可以帮助您从零开始,全面系统地学习 CST 微波工作的各项功能及其在微波射频、天线设计等领域的设计应用。且购买该套装,还可超值赠送 3 个月免费学习答疑...

课程网址: <http://www.edatop.com/peixun/cst/24.html>



## HFSS 天线设计培训课程套装

套装包含 6 门视频课程和 1 本图书,课程从基础讲起,内容由浅入深,理论介绍和实际操作讲解相结合,全面系统的讲解了 HFSS 天线设计的全过程。是国内最全面、最专业的 HFSS 天线设计课程,可以帮助您快速学习掌握如何使用 HFSS 设计天线,让天线设计不再难...

课程网址: <http://www.edatop.com/peixun/hfss/122.html>

## 13.56MHz NFC/RFID 线圈天线设计培训课程套装

套装包含 4 门视频培训课程,培训将 13.56MHz 线圈天线设计原理和仿真设计实践相结合,全面系统地讲解了 13.56MHz 线圈天线的工作原理、设计方法、设计考量以及使用 HFSS 和 CST 仿真分析线圈天线的具体操作,同时还介绍了 13.56MHz 线圈天线匹配电路的设计和调试。通过该套课程的学习,可以帮助您快速学习掌握 13.56MHz 线圈天线及其匹配电路的原理、设计和调试...

详情浏览: <http://www.edatop.com/peixun/antenna/116.html>



### 我们的课程优势:

- ※ 成立于 2004 年,10 多年丰富的行业经验,
- ※ 一直致力并专注于微波射频和天线设计工程师的培养,更了解该行业对人才的要求
- ※ 经验丰富的一线资深工程师讲授,结合实际工程案例,直观、实用、易学

### 联系我们:

- ※ 易迪拓培训官网: <http://www.edatop.com>
- ※ 微波 EDA 网: <http://www.mweda.com>
- ※ 官方淘宝店: <http://shop36920890.taobao.com>