



XAPP436 (v1.2) September 28, 2005

Managing Power with CoolRunner-II CPLDs

Summary

This application note demonstrates how multiple devices, including Virtex™-II, Spartan™-3, and Spartan™-3L FPGAs, can be effectively power managed by a single CoolRunner™-II CPLD. It is written with battery powered applications in mind.

Introduction

All chips draw power, but some applications are more sensitive than others to the amount drawn. Portable applications are sensitive simply because they draw from a battery. Most digital chips are designed to operate at 5V, 3.3V, 2.5V, 1.8V and so forth. This does not match well with today's battery voltages. Hence, there will be a regulator or two on most boards. Managing power will involve managing those regulators.

CoolRunner-II CPLDs were designed to operate with a core voltage of 1.8V, well suited to its 0.18 micron core, but its I/O structure supports 3.3V, 2.5V, 1.8V and 1.5V operation. Being standard low power CMOS, the I/Os also operate within that range, but are only speed specified at those voltages.

CoolRunner-II CPLDs have been successfully used as voltage translators, logic collection sites and even power management solutions. Their "early on" behavior makes them ideal for managing other chips' power. This application note focuses on using CoolRunner-II to manage power for Xilinx FPGAs, providing greater FPGA utility in a portable products. Additional CoolRunner-II qualities are shown to add value to reducing the portable product power budget in many cases.

The Power Equation

As expected, the starting point is physics, but CMOS power consumption can be deceptive. Simplistically, it follows an equation relating the switching speed of a logic gate output, times the voltage range over which it swings, times the load capacitance being driven. Adding in the static leakage component says it all.

Equation 1: $Power = V(VCF) + static\ power$

where:

V = output voltage swing

C = load capacitance

F = gate output switching frequency

Static power = somewhat constant value for many parts (often negligible)

This equation is a guideline. Originally developed for a simple CMOS inverter, it shows a trend, but only suggests how to reduce power. Equation 1 drives most CMOS power estimation tools. Xilinx provides several ways to estimate power, including spreadsheets, application notes and the XPower software, available with the ISE design suite.

© 2005 Xilinx, Inc. All rights reserved. All Xilinx trademarks, registered trademarks, patents, and further disclaimers are as listed at <http://www.xilinx.com/legal.htm>. All other trademarks and registered trademarks are the property of their respective owners. All specifications are subject to change without notice.

NOTICE OF DISCLAIMER: Xilinx is providing this design, code, or information "as is." By providing the design, code, or information as one possible implementation of this feature, application, or standard, Xilinx makes no representation that this implementation is free from any claims of infringement. You are responsible for obtaining any rights you may require for your implementation. Xilinx expressly disclaims any warranty whatsoever with respect to the adequacy of the implementation, including but not limited to any warranties or representations that this implementation is free from claims of infringement and any implied warranties of merchantability or fitness for a particular purpose.

The CoolRunner-II Solution

The CoolRunner-II approach to power management attacks both static and dynamic current. A battery is a charge reservoir with varying capabilities on voltage regulation, and in some cases an ability to be recharged. Each battery has its own qualities for delivering charge. Many batteries can deliver high currents for brief time periods, or smaller currents for longer times. Trade-offs can and must be made.

To get a feeling for power activity, let's look at a real world example, that was documented by Portelligent in their Report #116.02- 031023-1d. [Figure 1](#) is a reconstruction of their measurements made on an LG cell phone that was able to record video or take a picture. [Figure 1](#) shows power use while taking a photograph, with the cell phone camera.

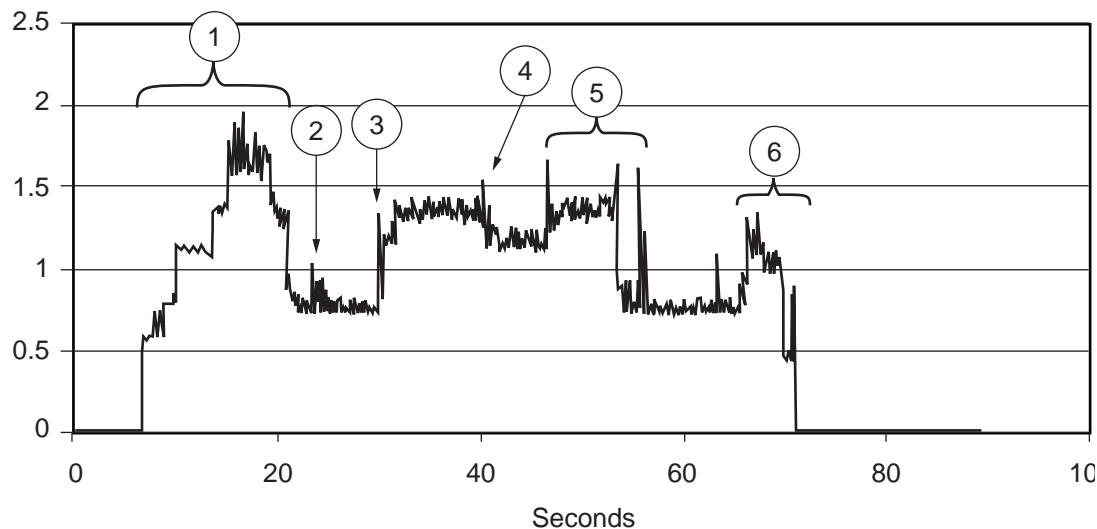

XAPP436_0110

Figure 1: Power Profile of LG Cell Phone Taking Still Photograph

The steps in taking a still photo are summarized as:

1. Power up and turn on the LCD backlight
2. Select the camera from menu
3. Select taking a still photo
4. Take the photo
5. Return to the main menu
6. Power down

The numbers in the diagram correspond to the activity list above. The Portelligent report explains the activity of the various chips within the camera, but [Figure 1](#) shows the composite power. There are many variables at play. Several chips within the camera receive power at different times. The display, camera chip and memories are involved here, but none of the standard cell phone capabilities - like making a call. That requires a different profile.

Nonetheless, these actions are typical of a large number of today's portable systems ranging from, walkie-talkies to PDAs, to video cameras, to the emerging software defined radios (SDR). 3G cell phones, in particular, with their added on applications and multi-band operation take this type of power management to new heights. In fact, these systems may rival some of the very power conscious projects like the Mars rover or other deep space probes in complexity. Power management is vital to all of these products.

Now, let's shift our attention to [Figure 2](#) which shows a small system using two FPGAs, an ASSP and a CoolRunner-II CPLD. Note, there are also multiple regulator chips shown (LDO), deriving their voltages by regulating down 5 volts. Another approach would be to regulate down from a battery, which most regulators can manage.

This particular example has the FPGAs being powered through the LDOs, but the ASSP simply connects to the distributed supply through a power FET. The particular FET will depend on the channel drop that can be tolerated, the turn on voltage and the power requirements of the ASSP. All power sources are controlled from logic signals coming off CoolRunner-II pins. The idea here is simple. When CoolRunner-II remains turned on, its power consumption is only in microamps (standby), whereas the FPGA current ranges into milliamps, depending on family and density.

In this example, we have combined a 150 nanometer Virtex-II FPGA and a 90 nanometer Spartan-3 FPGA. Each has different power needs, and illustrates choices and trade-offs to be made. As we will see later, the CoolRunner-II will be able to introduce an extra power down mode to the FPGAs, to reduce dynamic power. That will give a choice on whether to turn the part off, and pay for reconfiguration again, or just reduce dynamic power during standard operation. A reasonable regulator for the LDO 2 module is the TPS75003 from Texas Instruments™.

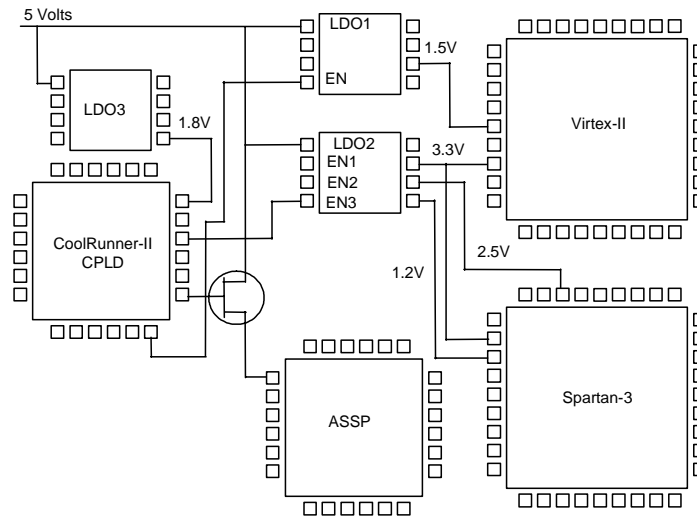

Figure 2: Multiple Chips “Power Managed” by a CoolRunner-II CPLD

The Virtex-II FPGA has reduced power up surge, but larger density parts may draw more current than a portable budget allows. Each FPGA might be a candidate for shutdown, except when needed. Table 1 summarizes quiescent internal current drawn by various Virtex-II family members. The dynamic current is a function of signal switching rates within the parts, and is design dependent. To estimate the power, you can use any of the methods mentioned earlier,

or simply build up the design and measure the requirement. Additional estimation resources are listed at the end. [Table 2](#) gives similar data for Spartan-3 FPGAs.

Table 1: Virtex-II FPGA Typical Internal Quiescent Currents

Virtex-II Device	Typical Internal Quiescent Supply Current ¹
XC2V40	3 mA
XC2V80	5 mA
XC2V250	8 mA
XC2V500	10 mA
XC2V1000	12 mA

1. Refer to the data sheet for the most accurate and up-to-date information

Table 2: Spartan-3/L FPGA Typical Internal Quiescent Currents

Spartan-3/L Device	Spartan-3 Typical Internal Quiescent Supply Current ¹	Spartan-3L Typical Internal Quiescent Supply Current ¹	Spartan-3L Quiescent ¹ Max (Hibernate Mode) ²
XC3S50	10 mA		
XC3S200	20 mA		
XC3S400	35 mA		
XC3S1000/L	65 mA	30 mA	6 mA
XC3S1500/L	65 mA	50 mA	8 mA

1. Refer to the data sheet for the most accurate and up-to-date information
2. Hibernate Mode available for Spartan-3L. [See DS313](#).

[Figure 3](#) shows how a current profile might look (averaged) over time. Usually, there is an initial surge as all on board capacitance becomes charged, various parts undergo configuration, initialization, bootstrapping, and so forth. Then things settle down, and various chips can be turned off, placed into low power, or whatever, as dictated by the application. The average current draw of this profile is substantially less than the initial surge value, so there may be a

payoff for turning chips off all together, or placing them in a low power mode. [Table 3](#) and [Table 4](#) give configuration times in byte wide mode at maximum speed.

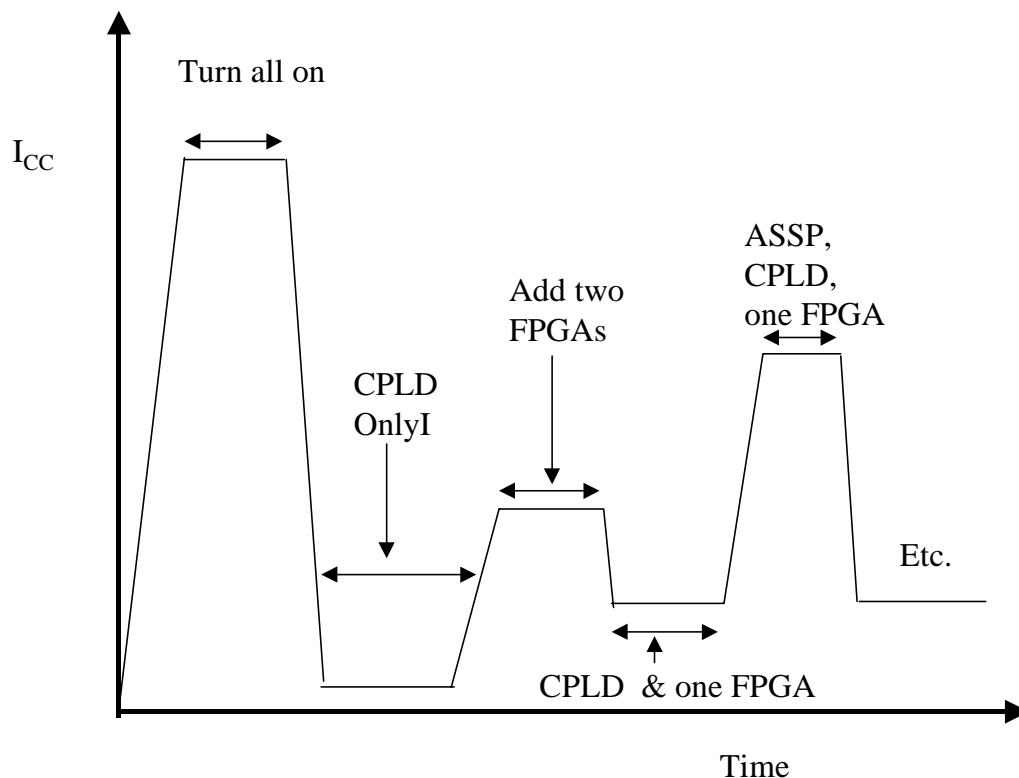

Figure 3: Current Profile of a System with Various Active Devices Over Time

Table 3: Virtex-II Configuration Parameters

Virtex-II Device	Configuration Bits	Configuration Time in Microseconds (at 50 MHz)
XC2V40	338,976	42.372
XC2V80	598,816	74.852
XC2V250	1,593,632	199.204
XC2V500	2,560,544	320.068
XC2V1000	4,082,592	510.324

Table 4: Spartan-3 Configuration Parameters

Spartan-3 Device	Configuration Bits	Configuration Time in Microseconds (at 50 MHz)
XC3S50	439,264	54.9
XC3S200	1,047,616	130.95
XC3S400	1,699,136	212.392
XC3S1000	3,223,488	402.936
XC3S1500	5,214,784	651.848

By lowering the average power, CoolRunner-II CPLDs can dramatically extend the battery life of a system in a way that brings the high flexibility and value of FPGAs into the portable world. Let's show how more value is gained using CoolRunner-II DataGATE.

DataGATE

DataGATE was designed to stop unwanted input switching from continuously draining power in CoolRunner-II CPLDs. Additional applications evolved from testing to security, and are documented in the Advanced Features and DataGATE application notes. However, one additional application is simply to "DataGATE" other chips.

Figure 4 shows how the DataGATE feature works. A metal rail (DataGATE Assertion Rail) circles the whole chip inside, near the pins. Each input site provides a place where the received signal can be blocked by a pass transistor, depending on two conditions. The first condition is an enable bit, selecting that pin to participate in the DataGATE decision. The second condition is simply whether the DataGATE Rail is asserted. If the rail is asserted and that input's participation selected, the input signal is blocked from penetrating the chip, until the rail releases assertion. It's that simple. When the rail asserts, blocking follows immediately. The previous input level automatically latches, so static CMOS logic signals forward into the CPLD core. The signal freezes until released. When the rail releases, switching action resumes.

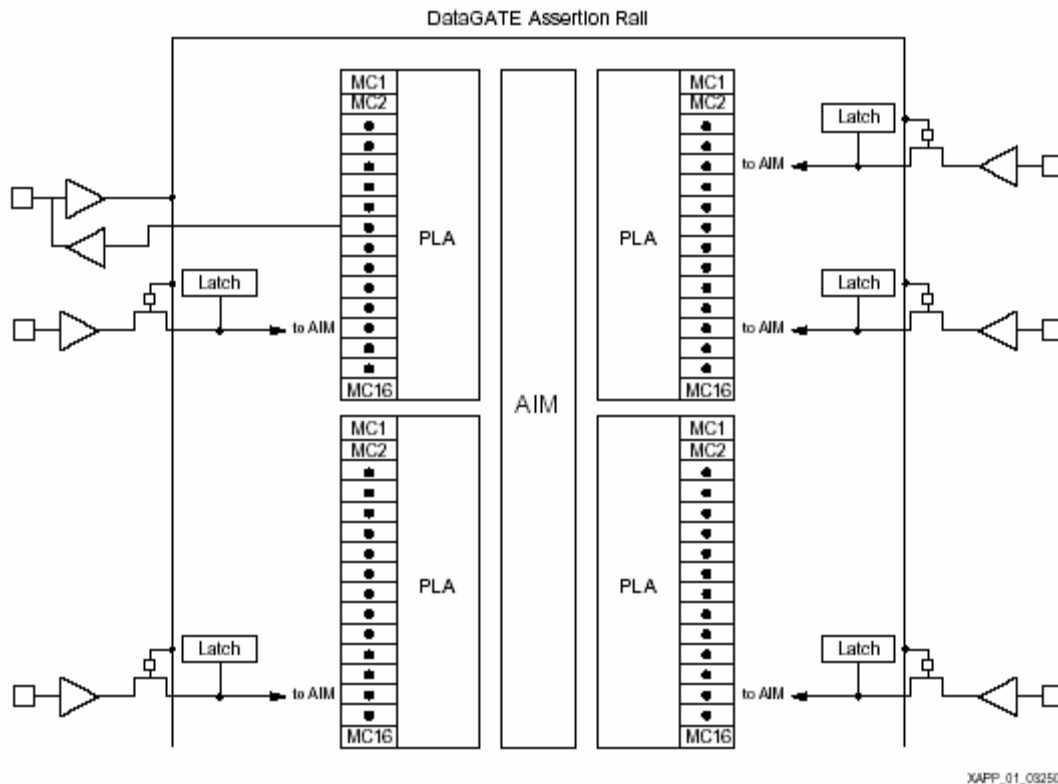

Figure 4: DataGATE Architecture

XAPP_01_092503

Figure 5 shows a close-up of how the pass transistor, enable cell and latch all connect to automatically block and freeze input signals that forward through the CoolRunner-II core.

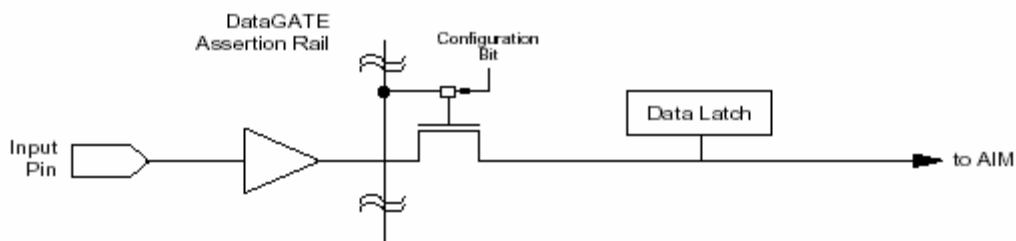

Figure 5: Close-up of DataGATE Switch Mechanism

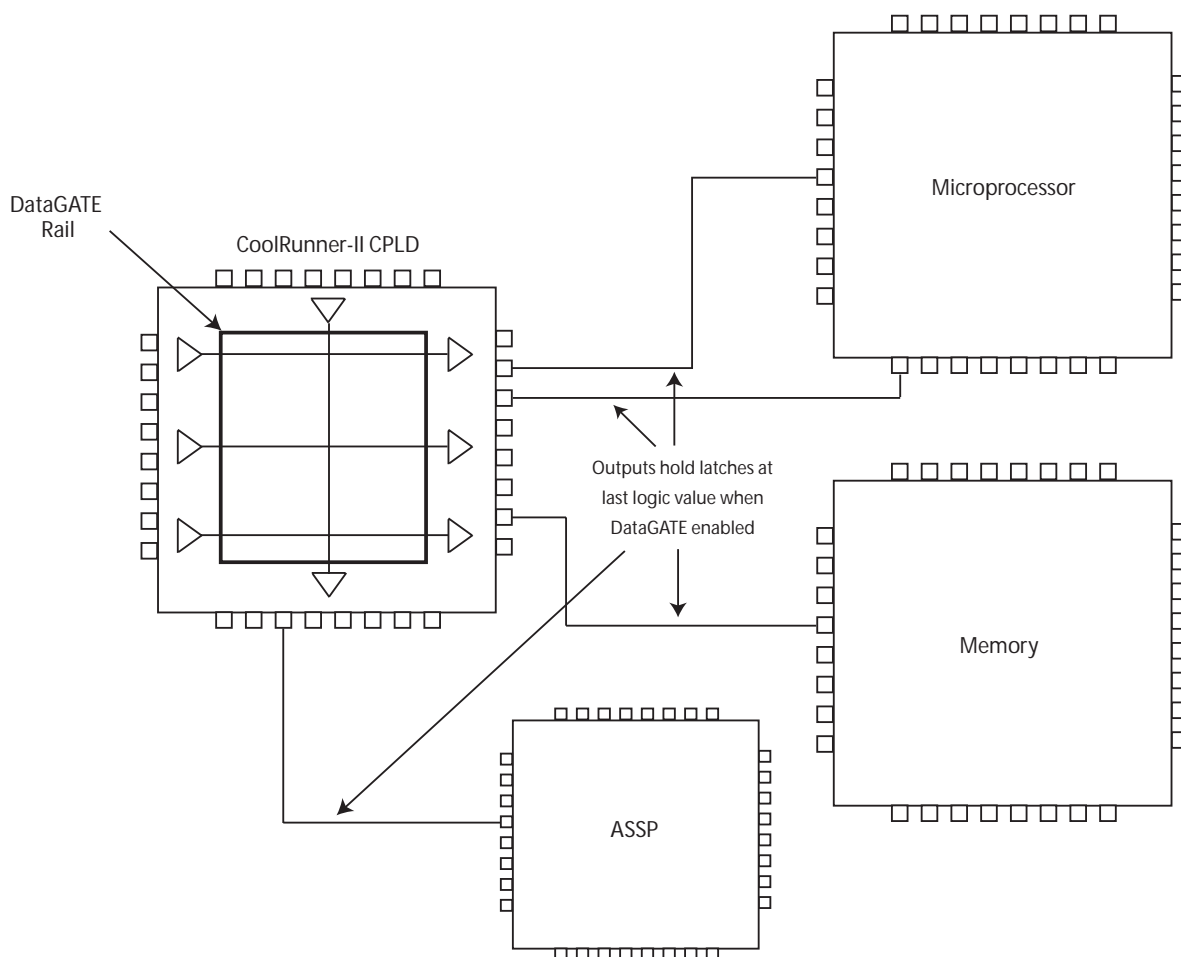

Figure 6: DataGATE Blocking Switching Activity to Other Chips

Figure 6 shows how signals passing through the CoolRunner-II DataGATE freeze signals to other chips. In this situation, we passed signals through the CoolRunner-II part, directly to the outside, where they drive to other chips. These will be held at the logic level that was last on the input pad, when DataGATE asserts. Should a 3-state signal be forwarded through the CoolRunner-II output pins, it will naturally be pulled to a high or low value, by the weak keeper that is on them, thereby covering the case when a “frozen” output gets 3-stated by another condition. An interesting proposition of passing signals through the CoolRunner-II is that it might be done as a natural side product of simply translating voltage levels on signals as they

interface through the CPLD. The DataGATE action, is really for free under those conditions, which occur frequently.

DataGATE is offered on CoolRunner-II CPLDs that have 128, 256, 384 and 512 macrocells. This extends into the hundreds of I/O pins that can be blocked as needed by the DataGATE facility. If multiple sets of pins need to be blocked, under different circumstances, then multiples of the smaller parts can be used to cover the number and condition needs of any given design.

At this point, we have not described what drives the DataGATE rail. It is very simple. One macrocell within a particular CoolRunner-II CPLD is designated as the "DataGATE" macrocell. It is identical to all other macrocells, which means any logic situation a designer sets up to drive that macrocell, asserts the DataGATE signal, if enabled in the design software. The DataGATE signal releases whenever the logic driving that macrocell dictates. An event as simple as a switching input can trigger the DataGATE macrocell, and an event as complex as a conditional state machine driving a timer can trigger the macrocell. Designers are free to dream up whatever they want. It is possible to block any input chosen, including clocks, but extreme care must be used when designing that way! All, none or any subset of the input pins can be blocked. Being a reprogrammable CPLD, this facility can be used experimentally to determine the best set of signals to "freeze" and the best set of circumstances to assert and release the rail.

So, how do you know what to "freeze?" That will vary, from system to system. Here's an example. When a microprocessor first bootstraps, it frequently sends values from its databus into a CPLD. These might be address values being loaded into comparators to select ranges of memory and I/O devices. Once those registers are initialized they need only compare against the address lines to operate. The databus connections are never needed again, but are still attached. DataGATE lets designers identify the time when the connection is no longer needed, and eliminate the extraneous switching that draws unneeded current. To learn more about other things you can do with DataGATE, check the references at the end.

Conclusion

We have omitted some details. What is the power impact of unpowered I/O pins attached to powered up termination resistors? How much leakage per pin occurs if an unpowered pin is driven by a powered one? Many questions can only be answered by assessing the specific situations with the particular device's data sheet in hand. We hope the methods described here will have some value by simply increasing your choices on power reduction methods.

CoolRunner-II CPLDs are designed to be inherently low power devices. Additional features within them – including DataGATE, can help other chips also reduce their overall power, when properly applied.

References

Portelligent Report #116.02-031023-1d

Estimation equation: <http://www.xilinx.com/bvdocs/appnotes/xapp317.pdf>

Low power design methods: <http://www.xilinx.com/bvdocs/appnotes/xapp346.pdf>

Decreasing power: <http://www.xilinx.com/bvdocs/appnotes/xapp347.pdf>

Accurate XPLA3 estimation: <http://www.xilinx.com/bvdocs/appnotes/xapp360.pdf>

Accurate CoolRunner-II Design estimation: <http://www.xilinx.com/bvdocs/appnotes/xapp377.pdf>

Powering CoolRunner-II: <http://www.xilinx.com/bvdocs/appnotes/xapp389.pdf>

DataGATE: <http://www.xilinx.com/bvdocs/appnotes/xapp395.pdf>

XPower <http://www.xilinx.com/xlnx/xebiz/designResources/>

Power Estimator (Spartan) http://www.xilinx.com/cgi-bin/power_tool/power_Spartan3

Power Estimator (Virtex-II) http://www.xilinx.com/cgi-bin/power_tool/power_Virtex2

Additional Information

[CoolRunner-II Data Sheets, Application Notes, and White Papers](#)

[Device Packages](#)

[Spartan-3 Data Sheets, Application Notes, and White Papers](#)

Revision History

The following table shows the revision history for this document.

Date	Version	Revision
11/29/04	1.0	Initial Xilinx release.
03/30/05	1.1	Removed incorrect reference to power surge. Added Spartan-3L.
09/28/05	1.2	Corrected part number on TI regulator, page 3.

射频和天线设计培训课程推荐

易迪拓培训(www.edatop.com)由数名来自于研发第一线的资深工程师发起成立,致力并专注于微波、射频、天线设计研发人才的培养;我们于 2006 年整合合并微波 EDA 网(www.mweda.com),现已发展成为国内最大的微波射频和天线设计人才培养基地,成功推出多套微波射频以及天线设计经典培训课程和 ADS、HFSS 等专业软件使用培训课程,广受客户好评;并先后与人民邮电出版社、电子工业出版社合作出版了多本专业图书,帮助数万名工程师提升了专业技术能力。客户遍布中兴通讯、研通高频、埃威航电、国人通信等多家国内知名公司,以及台湾工业技术研究院、永业科技、全一电子等多家台湾地区企业。

易迪拓培训课程列表: <http://www.edatop.com/peixun/rfe/129.html>



射频工程师养成培训课程套装

该套装精选了射频专业基础培训课程、射频仿真设计培训课程和射频电路测量培训课程三个类别共 30 门视频培训课程和 3 本图书教材;旨在引领学员全面学习一个射频工程师需要熟悉、理解和掌握的专业知识和研发设计能力。通过套装的学习,能够让学员完全达到和胜任一个合格的射频工程师的要求...

课程网址: <http://www.edatop.com/peixun/rfe/110.html>

ADS 学习培训课程套装

该套装是迄今国内最全面、最权威的 ADS 培训教程,共包含 10 门 ADS 学习培训课程。课程是由具有多年 ADS 使用经验的微波射频与通信系统设计领域资深专家讲解,并多结合设计实例,由浅入深、详细而又全面地讲解了 ADS 在微波射频电路设计、通信系统设计和电磁仿真设计方面的内容。能让您在最短的时间内学会使用 ADS,迅速提升个人技术能力,把 ADS 真正应用到实际研发工作中去,成为 ADS 设计专家...



课程网址: <http://www.edatop.com/peixun/ads/13.html>



HFSS 学习培训课程套装

该套课程套装包含了本站全部 HFSS 培训课程,是迄今国内最全面、最专业的 HFSS 培训教程套装,可以帮助您从零开始,全面深入学习 HFSS 的各项功能和在多个方面的工程应用。购买套装,更可超值赠送 3 个月免费学习答疑,随时解答您学习过程中遇到的棘手问题,让您的 HFSS 学习更加轻松顺畅...

课程网址: <http://www.edatop.com/peixun/hfss/11.html>

CST 学习培训课程套装

该培训套装由易迪拓培训联合微波 EDA 网共同推出,是最全面、系统、专业的 CST 微波工作室培训课程套装,所有课程都由经验丰富的专家授课,视频教学,可以帮助您从零开始,全面系统地学习 CST 微波工作的各项功能及其在微波射频、天线设计等领域的设计应用。且购买该套装,还可超值赠送 3 个月免费学习答疑...

课程网址: <http://www.edatop.com/peixun/cst/24.html>



HFSS 天线设计培训课程套装

套装包含 6 门视频课程和 1 本图书,课程从基础讲起,内容由浅入深,理论介绍和实际操作讲解相结合,全面系统的讲解了 HFSS 天线设计的全过程。是国内最全面、最专业的 HFSS 天线设计课程,可以帮助您快速学习掌握如何使用 HFSS 设计天线,让天线设计不再难...

课程网址: <http://www.edatop.com/peixun/hfss/122.html>

13.56MHz NFC/RFID 线圈天线设计培训课程套装

套装包含 4 门视频培训课程,培训将 13.56MHz 线圈天线设计原理和仿真设计实践相结合,全面系统地讲解了 13.56MHz 线圈天线的工作原理、设计方法、设计考量以及使用 HFSS 和 CST 仿真分析线圈天线的具体操作,同时还介绍了 13.56MHz 线圈天线匹配电路的设计和调试。通过该套课程的学习,可以帮助您快速学习掌握 13.56MHz 线圈天线及其匹配电路的原理、设计和调试...

详情浏览: <http://www.edatop.com/peixun/antenna/116.html>



我们的课程优势:

- ※ 成立于 2004 年,10 多年丰富的行业经验,
- ※ 一直致力并专注于微波射频和天线设计工程师的培养,更了解该行业对人才的要求
- ※ 经验丰富的一线资深工程师讲授,结合实际工程案例,直观、实用、易学

联系我们:

- ※ 易迪拓培训官网: <http://www.edatop.com>
- ※ 微波 EDA 网: <http://www.mweda.com>
- ※ 官方淘宝店: <http://shop36920890.taobao.com>