

## 1.0 Features

- No-load power consumption < 20 mW at 230 V<sub>ac</sub> with typical application circuit (5 star rating)
- Fast dynamic load response for both one-time and repetitive load transients
- Very tight constant voltage and constant current regulation over entire operating range
- Primary-side feedback eliminates opto-isolators and simplifies design
- *EZ-EMI*® design enhances manufacturability
- Intrinsically low common mode noise
- Optimized 72 kHz maximum PWM switching frequency achieves best size and efficiency
- Active start-up scheme enables fastest possible start-up
- Adaptive multi-mode PWM/PFM control improves efficiency
- Quasi-resonant operation for highest overall efficiency
- Direct drive of low-cost BJT switch
- Dynamic base current control
- No external compensation components required
- Complies with EPA 2.0 energy-efficiency specifications with ample margin
- Built-in soft start
- Built-in short circuit protection and output overvoltage protection
- Built-in current sense resistor short circuit protection
- No audible noise over entire operating range

## 2.0 Description

The iW1677 is a high performance AC/DC power supply controller which uses digital control technology to build peak current mode PWM flyback power supplies. The device together with an external active device (depletion mode NFET or NPN BJT) provides a fast start-up without compromising no-load power loss. The device directly drives a power BJT and operates in quasi-resonant mode to provide high efficiency along with a number of key built-in protection features while minimizing the external component count, simplifying EMI design and lowering the total bill of material cost. The iW1677 removes the need for secondary feedback circuitry while achieving excellent line and load regulation. It also eliminates the need for loop compensation components while maintaining stability over all operating conditions. Pulse-by-pulse waveform analysis allows for a loop response that is much faster than traditional solutions, resulting in improved dynamic load response for both one-time and repetitive load transients. The built-in power limit function enables optimized transformer design in universal off-line applications and allows for a wide input voltage range.

iWatt's innovative proprietary technology ensures that power supplies built with the iW1677 can achieve both highest average efficiency and less than 20 mW no-load power consumption, and have fast dynamic load response in a compact form factor. The active start-up scheme enables shortest possible start-up time without sacrificing no-load power loss.

## 3.0 Applications

- Compact AC/DC adapter/chargers for cell phones, PDAs, digital still cameras
- Linear AC/DC replacement

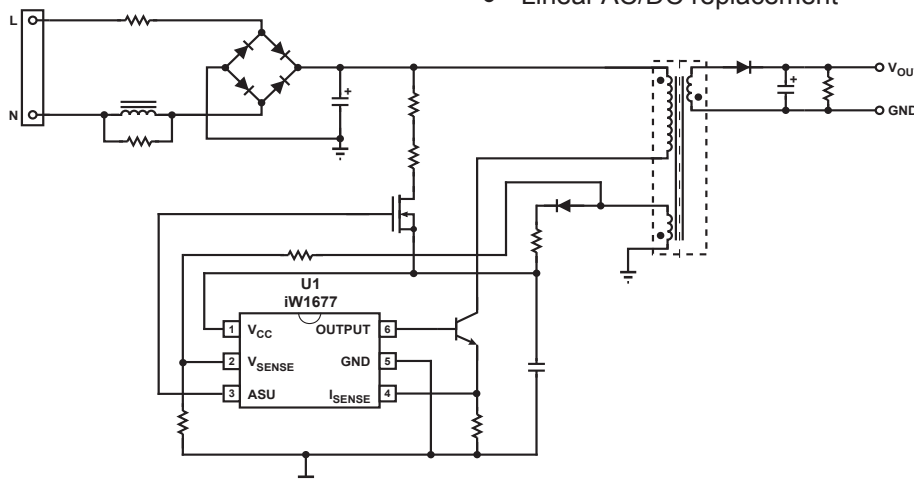

Figure 3.1: iW1677 Typical Application Circuit

(Achieving < 20 mW No-load Power Consumption. Using Depletion Mode NFET as Active Start-up Device)

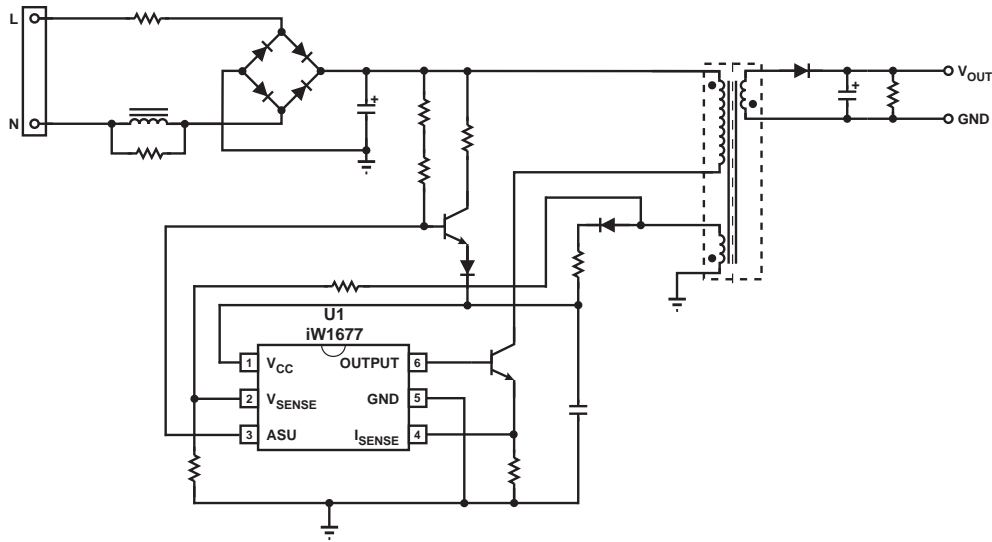

Figure 3.2: iW1677 Typical Application Circuit

(Achieving < 20 mW No-load Power Consumption. Using NPN BJT as Active Start-up Device)

## 4.0 Pinout Description

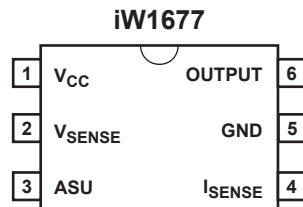

Figure 4.1: 6 Lead SOT-23 Package

Pin #	Name	Type	Pin Description
1	V <sub>CC</sub>	Power Input	Power supply for control logic.
2	V <sub>SENSE</sub>	Analog Input	Auxiliary voltage sense (used for primary regulation).
3	ASU	Output	Control signal for active start-up device (BJT or Depletion NFET).
4	I <sub>SENSE</sub>	Analog Input	Primary current sense. Used for cycle-by-cycle peak current control and limit.
5	GND	Ground	Ground.
6	OUTPUT	Output	Base drive for BJT.

## 5.0 Absolute Maximum Ratings

Absolute maximum ratings are the parameter values or ranges which can cause permanent damage if exceeded. For maximum safe operating conditions, refer to Electrical Characteristics in Section 6.0.

Parameter	Symbol	Value	Units
DC supply voltage range (pin 1, $I_{CC} = 20\text{mA max}$ )	$V_{CC}$	-0.3 to 18.0	V
Continuous DC supply current at $V_{CC}$ pin ( $V_{CC} = 15\text{ V}$ )	$I_{CC}$	20	mA
ASU output (pin 3)		-0.3 to 18.0	V
Output (pin 6)		-0.3 to 4.0	V
$V_{SENSE}$ input (pin 2, $I_{Vsense} \leq 10\text{ mA}$ )		-0.7 to 4.0	V
$I_{SENSE}$ input (pin 4)		-0.3 to 4.0	V
Maximum junction temperature	$T_{J\text{MAX}}$	150	°C
Storage temperature	$T_{STG}$	-65 to 150	°C
Lead temperature during IR reflow for $\leq 15$ seconds	$T_{LEAD}$	260	°C
Thermal resistance junction-to-ambient	$\theta_{JA}$	190	°C/W
ESD rating per JEDEC JESD22-A114		2,000	V
Latch-up test per JEDEC 78		$\pm 100$	mA

## 6.0 Electrical Characteristics

$V_{CC} = 12\text{ V}$ ,  $-40^\circ\text{C} \leq T_A \leq +85^\circ\text{C}$ , unless otherwise specified.

Parameter	Symbol	Test Conditions	Min	Typ	Max	Unit
<b><math>V_{SENSE}</math> SECTION (Pin 2)</b>						
Input leakage current	$I_{BVS}$	$V_{SENSE} = 2\text{ V}$			1	$\mu\text{A}$
Nominal voltage threshold	$V_{SENSE(NOM)}$	$T_A = 25^\circ\text{C}$ , negative edge	1.518	1.533	1.548	V
Output OVP threshold -00 (Note 1)	$V_{SENSE(MAX)}$	$T_A = 25^\circ\text{C}$ , negative edge		1.834		V
Output OVP threshold -01 (Note 1)	$V_{SENSE(MAX)}$	$T_A = 25^\circ\text{C}$ , negative edge Load = 100 %		1.926		V
Output OVP threshold -03 (Note 1)	$V_{SENSE(MAX)}$	$T_A = 25^\circ\text{C}$ , negative edge Load = 100 %		1.972		V
Output OVP threshol -05 (Note 1)	$V_{SENSE(MAX)}$	$T_A = 25^\circ\text{C}$ , negative edge Load = 100 %		1.880		V

## 6.0 Electrical Characteristics

$V_{CC} = 12\text{ V}$ ,  $-40^{\circ}\text{C} \leq T_A \leq +85^{\circ}\text{C}$ , unless otherwise specified.

Parameter	Symbol	Test Conditions	Min	Typ	Max	Unit
<b>I<sub>SENSE</sub> SECTION (Pin 4)</b>						
Overcurrent threshold	$V_{OCP}$		1.11	1.15	1.19	V
I <sub>SENSE</sub> regulation upper limit (Note 1)	$V_{IPK(HIGH)}$			1.0		V
I <sub>SENSE</sub> regulation lower limit (Note 1)	$V_{IPK(LOW)}$			0.23		V
Input leakage current	$I_{LK}$	$I_{SENSE} = 1.0\text{ V}$			1	$\mu\text{A}$
<b>OUTPUT SECTION (Pin 6)</b>						
Output low level ON-resistance	$R_{DS(ON)LO}$	$I_{SINK} = 5\text{ mA}$		1	3	$\Omega$
Switching frequency (Note 2)	$f_{SW}$	> 50% load		72		kHz
<b>V<sub>CC</sub> SECTION (Pin 1)</b>						
Maximum operating voltage (Note 1)	$V_{CC(MAX)}$				16	V
Start-up threshold	$V_{CC(ST)}$	$V_{CC}$ rising	10.0	11.0	12.0	V
Undervoltage lockout threshold	$V_{CC(UVL)}$	$V_{CC}$ falling	3.8	4.0	4.2	V
Start-up current	$I_{IN(ST)}$	$V_{CC} = 10\text{ V}$	1.0	1.7	3.0	$\mu\text{A}$
Quiescent current	$I_{CCQ}$	No $I_B$ current		2.7	4.0	mA
Zener breakdown voltage	$V_{ZB}$	Zener current = 5 mA $T_A = 25^{\circ}\text{C}$	18.5	19.5	20.5	V
<b>ASU SECTION (Pin 3)</b>						
Maximum operating voltage (Note 1)	$V_{ASU(MAX)}$				16	V
Resistance between $V_{CC}$ and ASU	$R_{V_{CC\_ASU}}$			830		k $\Omega$

### Notes:

Note 1. These parameters are not 100% tested, guaranteed by design and characterization.

Note 2. Operating frequency varies based on the load conditions, see Section 9.6 for more details.

7.0 Typical Performance Characteristics

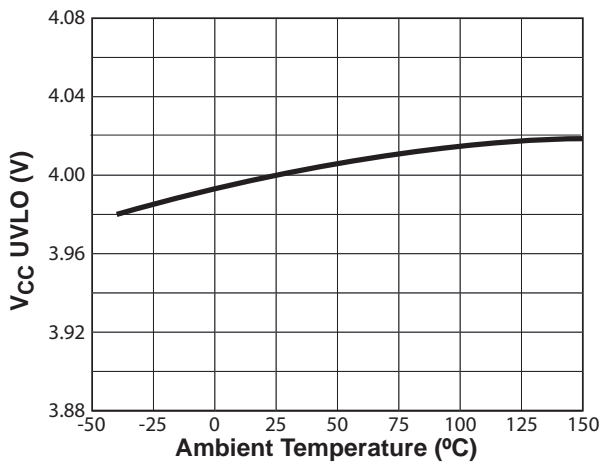

Figure 7.1 : V<sub>CC</sub> UVLO vs. Temperature

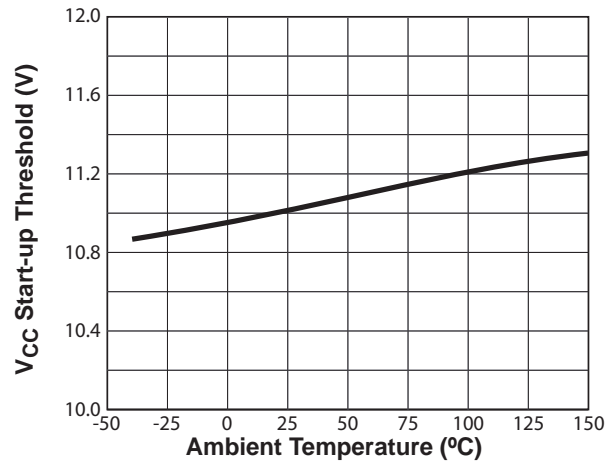

Figure 7.2 : Start-Up Threshold vs. Temperature

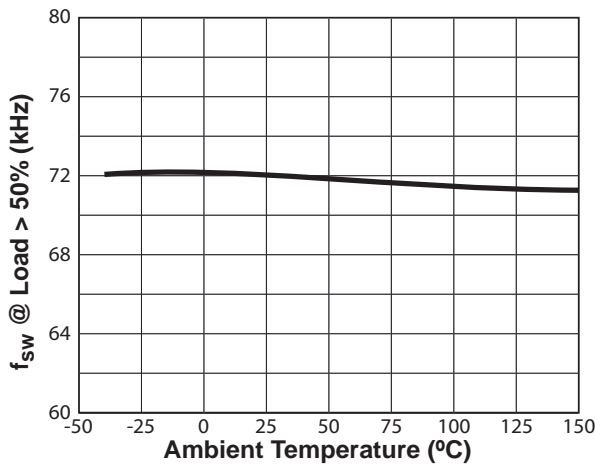

Figure 7.3 : Switching Frequency vs. Temperature<sup>1</sup>

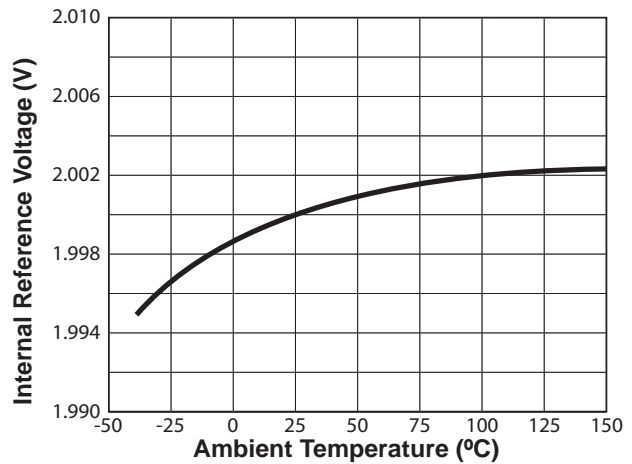

Figure 7.4 : Internal Reference vs. Temperature

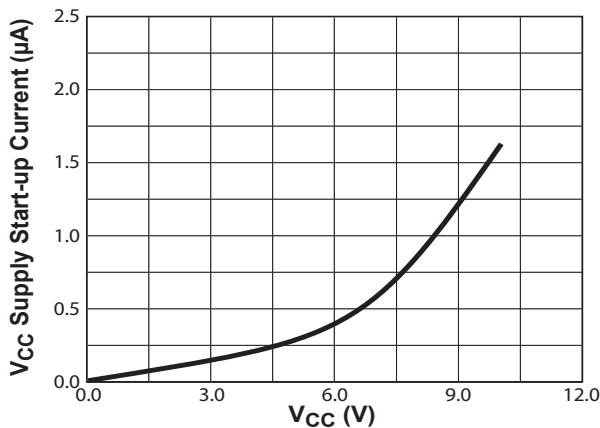

Figure 7.5 : V<sub>CC</sub> vs. V<sub>CC</sub> Supply Start-up Current

Notes:

Note 1. Operating frequency varies based on the load conditions, see Section 9.6 for more details.



### 9.1 Pin Detail

#### Pin 1 – $V_{CC}$

Power supply for the controller during normal operation. The controller will start up when  $V_{CC}$  reaches 11.0 V (typical) and will shut-down when the  $V_{CC}$  voltage is 4.0 V (typical). A decoupling capacitor of 0.1  $\mu$ F or so should be connected between the  $V_{CC}$  pin and GND.

#### Pin 2 – $V_{SENSE}$

Sense signal input from auxiliary winding. This provides the secondary voltage feedback used for output regulation.

#### Pin 3 – ASU

Control signal for active startup device. This signal is pulled low after start-up is finished to cut off the active device.

#### Pin 4 – $I_{SENSE}$

Primary current sense. Used for cycle-by-cycle peak current control and limit.

#### Pin 5 – GND

Ground.

#### Pin 6 – OUTPUT

Base drive for the external power BJT switch.

### 9.2 Active Start-up and Soft-start

Refer to Figure 3.1 and Figure 3.2 for active start-up circuits using external depletion NFET and BJT respectively. Prior to start-up, the depletion NFET or the BJT is turned on, allowing the start-up current to charge the  $V_{CC}$  bypass capacitor. When the  $V_{CC}$  bypass capacitor is charged to a voltage higher than the start-up threshold  $V_{CC(ST)}$ , the ENABLE signal becomes active and the iW1677 commences soft start function. During this start-up process an adaptive soft-start control algorithm is applied, where the initial output pulses will be small and gradually get larger until the full pulse width is achieved. The peak current is limited cycle by cycle by the  $I_{PEAK}$  comparator. If at any time the  $V_{CC}$  voltage drops below undervoltage lockout (UVLO) threshold  $V_{CC(UVL)}$  then the iW1677 goes to shutdown. At this time ENABLE signal becomes low and the  $V_{CC}$  capacitor begins to charge up again towards the start-up threshold to initiate a new soft-start process.

While the ENABLE signal initiates the soft-start process, it also pulls down the ASU pin voltage at the same time, which turns off the depletion NFET or the BJT, thus minimizing the no-load standby power consumption. For the active start-up scheme in Figure 3.2, the start-up resistors connected between the base of the BJT and DC input still conduct current after start-up is finished. Their resistance needs to be large enough to minimize no-load power consumption, meanwhile the BJT with ample gain should be selected in order to obtain a sufficient charge current for a fast start-up.

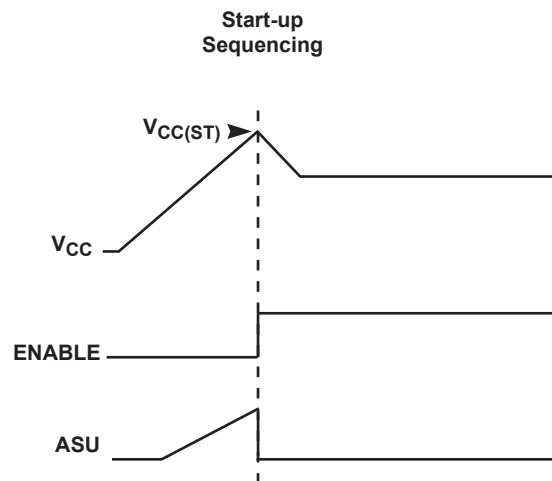

Figure 9.1: Start-up Sequencing Diagram

### 9.3 Understanding Primary Feedback

Figure 9.2 illustrates a simplified flyback converter. When the switch Q1 conducts during  $t_{ON}(t)$ , the current  $i_g(t)$  is directly drawn from rectified sinusoid  $v_{in}(t)$ . The energy  $E_g(t)$  is stored in the magnetizing inductance  $L_M$ . The rectifying diode D1 is reverse biased and the load current  $I_o$  is supplied by the secondary capacitor  $C_o$ . When Q1 turns off, D1 conducts and the stored energy  $E_g(t)$  is delivered to the output.

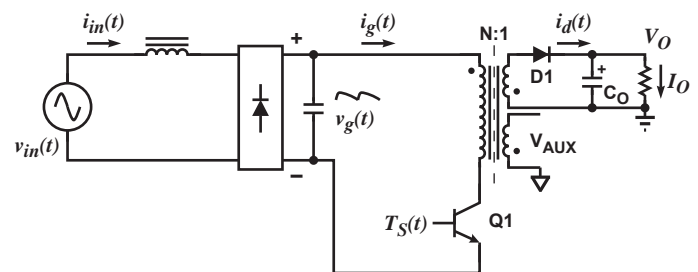

Figure 9.2: Simplified Flyback Converter

In order to tightly regulate the output voltage, the information about the output voltage and load current need

to be accurately sensed. In the DCM flyback converter, this information can be read via the auxiliary winding or the primary magnetizing inductance ( $L_M$ ). During the Q1 on-time, the load current is supplied from the output filter capacitor  $C_O$ . The voltage across  $L_M$  is  $v_g(t)$ , assuming the voltage dropped across Q1 is zero. The current in Q1 ramps up linearly at a rate of:

$$\frac{di_g(t)}{dt} = \frac{v_g(t)}{L_M} \quad (9.1)$$

At the end of on-time, the current has ramped up to:

$$i_{g\_peak}(t) = \frac{v_g(t) \times t_{ON}}{L_M} \quad (9.2)$$

This current represents a stored energy of:

$$E_g = \frac{L_M}{2} \times i_{g\_peak}(t)^2 \quad (9.3)$$

When Q1 turns off at  $t_O$ ,  $i_g(t)$  in  $L_M$  forces a reversal of polarities on all windings. Ignoring the commutation-time caused by the leakage inductance  $L_K$  at the instant of turn-off  $t_O$ , the primary current transfers to the secondary at a peak amplitude of:

$$i_d(t) = \frac{N_P}{N_S} \times i_{g\_peak}(t) \quad (9.4)$$

Assuming the secondary winding is master, and the auxiliary winding is slave,

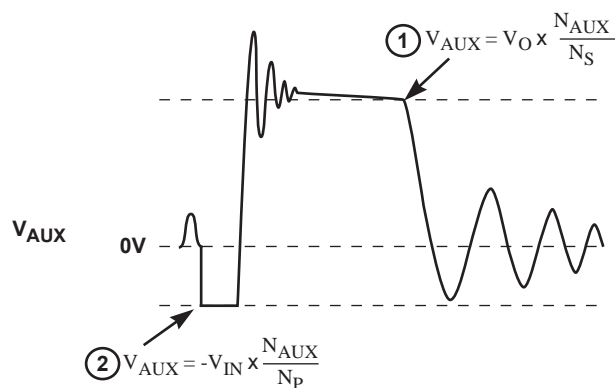

Figure 9.3: Auxiliary Voltage Waveforms

The auxiliary voltage is given by:

$$V_{AUX} = \frac{N_{AUX}}{N_S} (V_O + \Delta V) \quad (9.5)$$

and reflects the output voltage as shown in Figure 9.3.

The voltage at the load differs from the secondary voltage by a diode drop and IR losses. Thus, if the secondary voltage is always read at a constant secondary current, the difference between the output voltage and the secondary voltage will be a fixed  $\Delta V$ . Furthermore, if the voltage can be read when the secondary current is small,  $\Delta V$  will also be small. With the iW1677,  $\Delta V$  can be ignored.

The real-time waveform analyzer in the iW1677 reads this information cycle by cycle. The part then generates a feedback voltage  $V_{FB}$ . The  $V_{FB}$  signal precisely represents the output voltage under most conditions and is used to regulate the output voltage.

## 9.4 Constant Voltage Operation

After soft-start has been completed, the digital control block measures the output conditions. It determines output power levels and adjusts the control system according to a light load or heavy load. If this is in the normal range, the device operates in the Constant Voltage (CV) mode, and changes the pulse width ( $T_{ON}$ ) and off time ( $T_{OFF}$ ) in order to meet the output voltage regulation requirements.

If no voltage is detected on  $V_{SENSE}$  it is assumed that the auxiliary winding of the transformer is either open or shorted and the iW1677 shuts down.

## 9.5 Constant Current Operation

The constant current (CC) mode is useful in battery charging applications. During this mode of operation the iW1677 will regulate the output current at a constant level regardless of the output voltage, while avoiding continuous conduction mode.

To achieve this regulation the iW1677 senses the load current indirectly through the primary current. The primary current is detected by the  $I_{SENSE}$  pin through a resistor from the BJT emitter to ground.



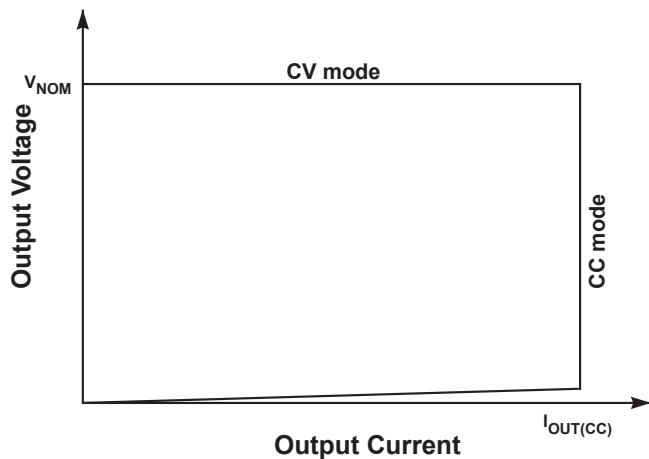

Figure 9.4: Power Envelope

## 9.6 Multi-Mode PWM/PFM Control and Quasi-Resonant Switching

The iW1677 uses a proprietary adaptive multi-mode PWM / PFM control to dramatically improve the light-load efficiency and thus the overall average efficiency.

During the constant voltage (CV) operation, the iW1677 normally operates in a pulse-width-modulation (PWM) mode during heavy load conditions. In the PWM mode, the switching frequency keeps around constant. As the output load  $I_{OUT}$  is reduced, the on-time  $t_{ON}$  is decreased, and the controller adaptively transitions to a pulse-frequency-modulation (PFM) mode. During the PFM mode, the BJT is turned on for a set duration under a given instantaneous rectified AC input voltage, but its off time is modulated by the load current. With a decreasing load current, the off time increases and thus the switching frequency decreases.

When the switching frequency approaches to human ear audio band, the iW1677 transitions to a second level of PWM mode, namely Deep PWM mode (DPWM). During the DPWM mode, the switching frequency keeps around 25 kHz in order to avoid audible noise. As the load current is further reduced, the iW1677 transitions to a second level of PFM mode, namely Deep PFM mode (DPFM), which can reduce the switching frequency to a very low level. Although the switching frequency drops across the audible frequency range during the DPFM mode, the output current in the power converter has reduced to an insignificant level in the DPWM mode before transitioning to the DPFM mode. Therefore, the power converter practically produces no audible noise, while achieving high efficiency across varying load conditions.

As the load current reduces to very low or no-load condition, the iW1677 transitions from the DPFM to the third level of PWM mode, namely Deep-Deep PWM mode (DDPWM), where the switching frequency is fixed at around 2.1 kHz.

The iW1677 also incorporates a unique proprietary quasi-resonant switching scheme that achieves valley-mode turn on for every PWM/PFM switching cycle, during all PFM and PWM modes and in both CV and CC operations. This unique feature greatly reduces the switching loss and dv/dt across the entire operating range of the power supply. Due to the nature of quasi-resonant switching, the actual switching frequency can vary slightly cycle by cycle, providing the additional benefit of reducing EMI. Together these innovative digital control architecture and algorithms enable the iW1677 to achieve highest overall efficiency and lowest EMI, without causing audible noise over entire operating range.

## 9.7 Less Than 20 mW No-Load Power with Fast Load Transient Response

The iW1677 features the distinctive DDPWM control at no-load conditions to help achieve super-low no-load power consumption (< 20 mW for typical applications) and meanwhile to ensure fast dynamic load response. The power supply system designs including the pre-load resistor selection should ensure the power supply can stably operate in the DDPWM mode at the steady-state no-load condition. If the pre-load resistor is too small, the no-load power consumption will increase; on the other hand, if it is too large, the output voltage may increase and even cause overvoltage since the switching frequency is fixed at around 2.1 kHz. For typical designs, the pre-load resistor is in the range of 5 kΩ to 8 kΩ.

Aside from the appropriate use of pre-load resistor, the iW1677 enjoys a few other features to bring down no-load power consumption as well. First, the iW1677 implements an intelligent low-power management technique that achieves ultra-low chip operating current at the no-load, typically less than 400 μA. Second, the use of the power switch of BJT instead of MOSFET requires a lower driving voltage, enabling a low UVLO threshold as low as 4.0 V (typical). The power supply system design can fully utilize this low UVLO feature to have a low Vcc voltage at the no-load operation in order to minimize the no-load power. In addition, the active start-up scheme with depletion NFET eliminates the startup resistor power consumption after the ENABLE signal becomes active. All together these features ensure with the lowest system cost power supplies built with the iW1677 can achieve less than 20 mW no-load power consumption at 230 Vac input and very tight constant voltage and constant

current regulation over the entire operating range including the no-load operation.

While achieving super-low no-load power consumption, the iW1677 implements innovative proprietary digital control technology to intelligently detect any load transient events, and achieve fast dynamic load response for both one-time and repetitive load transients. In particular, for load transients that are demanded in some applications as from absolutely no load to full load, the iW1677 can still guarantee a fast enough response to meet the most stringent requirements, with the no-load operating frequency designed at around 2.1 kHz.

## 9.8 Variable Frequency Operation Mode

At each of the switching cycles, the falling edge of  $V_{SENSE}$  will be checked. If the falling edge of  $V_{SENSE}$  is not detected, the off-time will be extended until the falling edge of  $V_{SENSE}$  is detected. The maximum allowed transformer reset time is 110  $\mu$ s. When the transformer reset time reaches 110  $\mu$ s, the iW1677 shuts off.

## 9.9 Internal Loop Compensation

The iW1677 incorporates an internal Digital Error Amplifier with no requirement for external loop compensation. For a typical power supply design, the loop stability is guaranteed to provide at least 45 degrees of phase margin and -20 dB of gain margin.

## 9.10 Voltage Protection Features

The secondary maximum output DC voltage is limited by the iW1677. When the  $V_{SENSE}$  signal exceeds the output OVP threshold at point 1 indicated in Figure 9.3 the iW1677 shuts down.

The iW1677 protects against input line undervoltage by setting a maximum  $T_{ON}$  time. Since output power is proportional to the squared  $V_{IN}T_{ON}$  product, then for a given output power, as  $V_{IN}$  decreases the  $T_{ON}$  will increase. Thus by knowing when the maximum  $T_{ON}$  time occurs the iW1677 detects that the minimum  $V_{IN}$  is reached, and shuts down. The maximum  $t_{ON}$  limit is set to 13.8  $\mu$ s. Also, the iW1677 monitors the voltage on the  $V_{CC}$  pin and when the voltage on this pin is below UVLO threshold the IC shuts down immediately.

When any of these faults are met the IC remains biased to discharge the  $V_{CC}$  supply. Once  $V_{CC}$  drops below UVLO threshold, the controller resets itself and then initiates a new soft-start cycle. The controller continues attempting start-up until the fault condition is removed.

## 9.11 PCL, OCP and SRS Protection

Peak-current limit (PCL), over-current protection (OCP) and sense-resistor short protection (SRSP) are features built-in to the iW1677. With the  $I_{SENSE}$  pin the iW1677 is able to monitor the peak primary current. This allows for cycle by cycle peak current control and limit. When the primary peak current multiplied by the  $I_{SENSE}$  resistor is greater than 1.15 V, over current (OCP) is detected and the IC will immediately turn off the base driver until the next cycle. The output driver will send out a switching pulse in the next cycle, and the switching pulse will continue if the OCP threshold is not reached; or, the switching pulse will turn off again if the OCP threshold is reached. If the OCP occurs for several consecutive switching cycles, the iW1677 shuts down.

If the  $I_{SENSE}$  resistor is shorted there is a potential danger of the over current condition not being detected. Thus, the IC is designed to detect this sense-resistor-short fault after startup and shut down immediately. The  $V_{CC}$  will be discharged since the IC remains biased. Once  $V_{CC}$  drops below the UVLO threshold, the controller resets itself and then initiates a new soft-start cycle. The controller continues attempting to startup, but does not fully startup until the fault condition is removed.

## 9.12 Dynamic Base Current Control

One important feature of the iW1677 is that it directly drives a BJT switching device with dynamic base current control to optimize performance. The BJT base current ranges from 13 mA to 40 mA, and is dynamically controlled according to the power supply load change. The higher the output power, the higher the base current. Specifically, the base current is related to  $V_{IPK}$ , as shown in Figure 9.5.

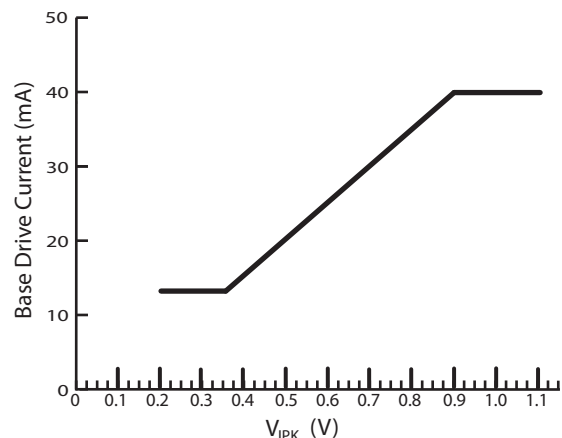

Figure 9.5: Base Drive Current vs.  $V_{IPK}$

### 9.13 Cable Drop Compensation

---

The iW1677 incorporates an innovative method to compensate for any IR drop in the secondary circuitry including cable and cable connector. A 2.5-W adapter with 5 V DC output has 3% deviation at 0.5 A load current due to the drop across a 24 AWG, 1.8 meter DC cable without cable compensation. The iW1677 compensates for this voltage drop by providing a voltage offset to the feedback signal based on the amount of load current detected.

The “Cable Comp” specified in the Table in Section 11.0 refers to the voltage increment at PCB end from no-load to full-load conditions in the CV mode, with the assumption that the secondary diode voltage drop can be ignored at the point when the secondary voltage is sensed. Also, the “Cable Comp” is specified based on the nominal output voltage of 5 V. For different output voltage, the actual voltage increment needs to be scaled accordingly.

To calculate the amount of cable compensation needed, take the resistance of the cable and connector and multiply by the maximum output current.

**10.0 Physical Dimensions**

6-Lead SOT Package

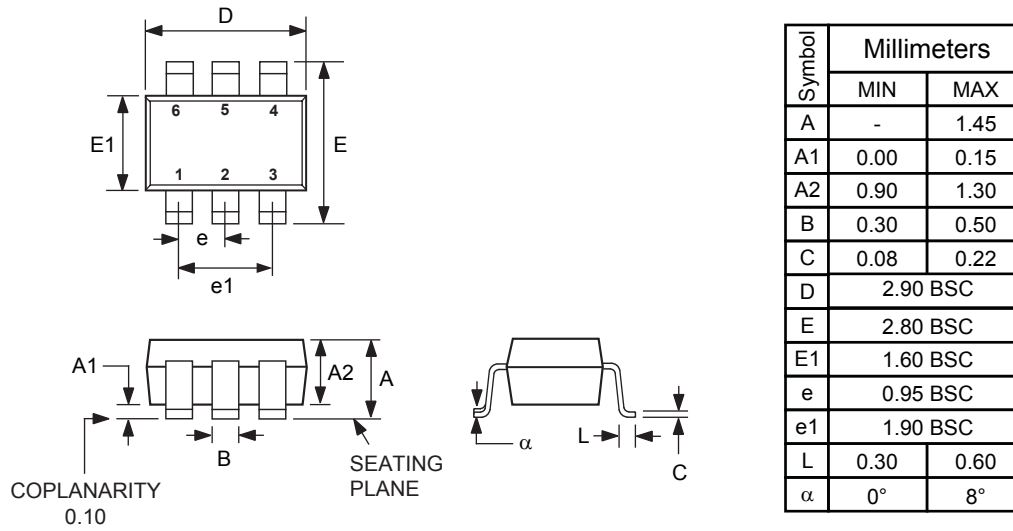

Figure 10.1: Physical dimensions, 6-lead SOT-23 package

Compliant to JEDEC Standard MO-178AB

Controlling dimensions are in millimeters

This package is RoHS compliant and Halide free.

Soldering Temperature Resistance:

- [a] Package is IPC/JEDEC Std 020D Moisture Sensitivity Level 1
- [b] Package exceeds JEDEC Std No. 22-A111 for Solder Immersion Resistance; packages can withstand 10 s immersion < 270°C

Dimension D does not include mold flash, protrusions or gate burrs. Mold flash, protrusions or gate burrs shall not exceed 0.25 mm per side. D and E1 dimensions are determined at datum H.

The package top may be smaller than the package bottom. Dimensions D and E1 are determined at the outermost extremes of the plastic body exclusive of mold flash, tie bar burrs and interlead flash, but including any mismatch between top and bottom of the plastic body. D and E1 dimensions are determined at datum H.

**11.0 Ordering Information**

Part Number	Options	Package	Description
iW1677-00	Cable Comp = 0 mV	SOT-23	Tape & Reel <sup>1</sup>
iW1677-01	Cable Comp = 300 mV	SOT-23	Tape & Reel <sup>1</sup>
iW1677-03	Cable Comp = 450 mV	SOT-23	Tape & Reel <sup>1</sup>
iW1677-05	Cable Comp = 150 mV	SOT-23	Tape & Reel <sup>1</sup>

Note 1: Tape & Reel packing quantity is 3,000 per reel. Minimum ordering quantity is 3,000.

## About iWatt

iWatt Inc. is a fabless semiconductor company that develops intelligent power management ICs for computer, communication, and consumer markets. The company's patented *pulseTrain*™ technology, the industry's first truly digital approach to power system regulation, is revolutionizing power supply design.

### Trademark Information

© 2008 iWatt, Inc. All rights reserved. iWatt, and *pulseTrain* are trademarks of iWatt, Inc. All other trademarks and registered trademarks are the property of their respective companies.

### Contact Information

**Web:** <http://www.iwatt.com>

**E-mail:** [info@iwatt.com](mailto:info@iwatt.com)

**Phone:** 408-374-4200

**Fax:** 408-341-0455

**iWatt Inc.**

101 Albright Way

Los Gatos CA 95032-1827

### Disclaimer

iWatt reserves the right to make changes to its products and to discontinue products without notice. The applications information, schematic diagrams, and other reference information included herein is provided as a design aid only and are therefore provided as-is. iWatt makes no warranties with respect to this information and disclaims any implied warranties of merchantability or non-infringement of third-party intellectual property rights.

Certain applications using semiconductor products may involve potential risks of death, personal injury, or severe property or environmental damage ("Critical Applications").

IWATT SEMICONDUCTOR PRODUCTS ARE NOT DESIGNED, INTENDED, AUTHORIZED, OR WARRANTED TO BE SUITABLE FOR USE IN LIFE-SUPPORT APPLICATIONS, DEVICES OR SYSTEMS, OR OTHER CRITICAL APPLICATIONS.

Inclusion of iWatt products in critical applications is understood to be fully at the risk of the customer. Questions concerning potential risk applications should be directed to iWatt, Inc.

iWatt semiconductors are typically used in power supplies in which high voltages are present during operation. High-voltage safety precautions should be observed in design and operation to minimize the chance of injury.