

ALTERA CYCLONE II EP2C70 Development & Education BOARD

SCHEMATIC	CONTENT	PAGE
TOP	COVER PAGE , TOP	01 ~ 03
MEMORY	SDRAM , SSRAM , FLASH , SD CARD	04 ~ 06
DISPLAY	LCD , LED , 7SEGMENT	07 ~ 08
IN/OUT	CLOCK, IrDA, PS2 , RS232 , BUTTON , SWITCH , CONNECTOR	09 ~ 13
ETHERNET	DM9000A	14 ~ 14
VIDEO	ADV7123, ADV7180	15 ~ 16
AUDIO	WM8731	17 ~ 17
USB DEVICE	ISP1362	18 ~ 18
FPGA	Cyclone II EP2C70 BANK1..BANK8 , POWER , CONFIG	19 ~ 23
POWER	POWER 1.2V, 1.8V, 3.3V, 5V	24 ~ 24
USB BLASTER	USB BLASTER	25 ~ 25



Copyright (c) 2007 by Terasic Technologies Inc. Taiwan.
All rights reserved.

No part of this schematic design may be reproduced, duplicated, or used
without the prior written permission of Terasic.

Title		
ALTERA DE2-70		
Size	Document Number	Rev
B	COVER PAGE	1.0
Date:	Monday, November 26, 2007	Sheet 1 of 25

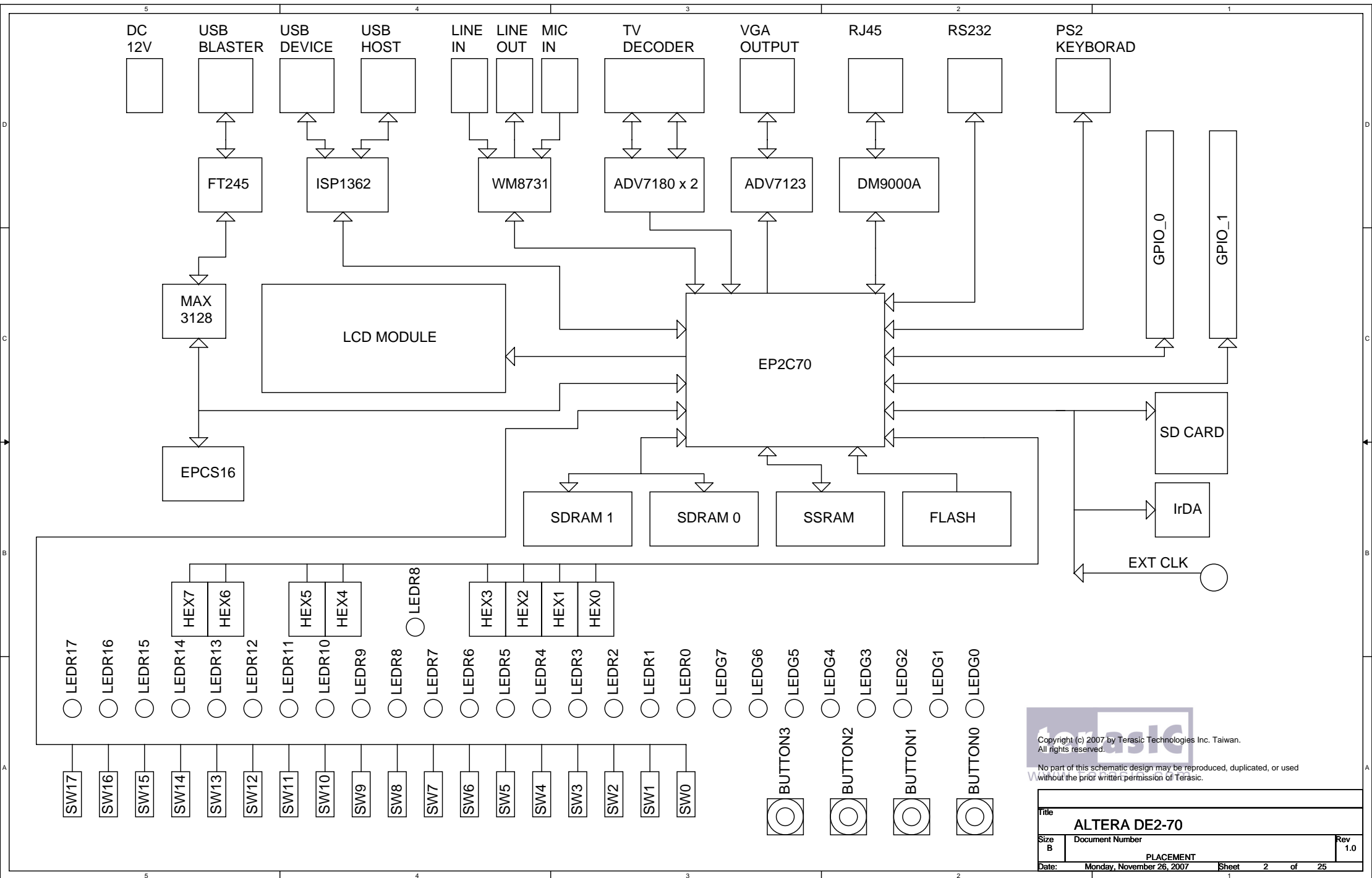



 Copyright (c) 2007 by Terasic Technologies Inc. Taiwan. All rights reserved.
 No part of this schematic design may be reproduced, duplicated, or used without the prior written permission of Terasic.

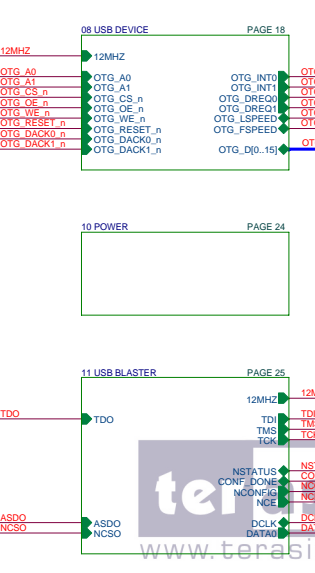
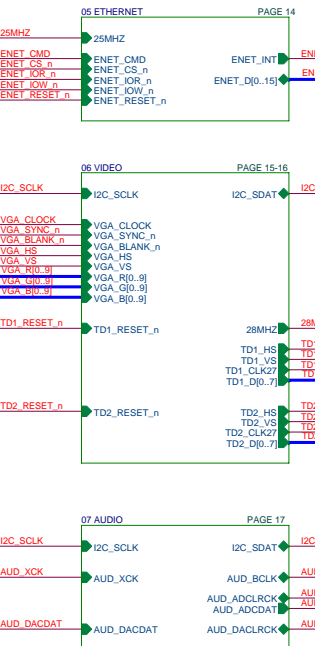
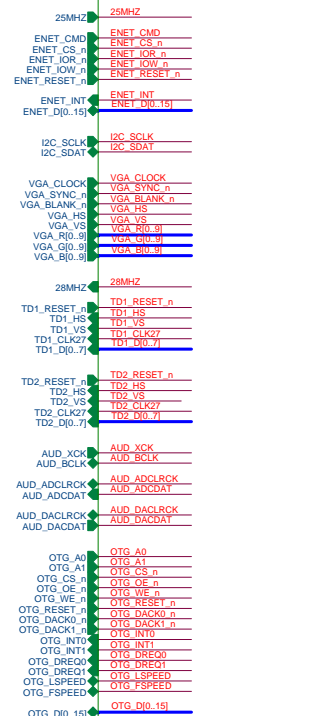
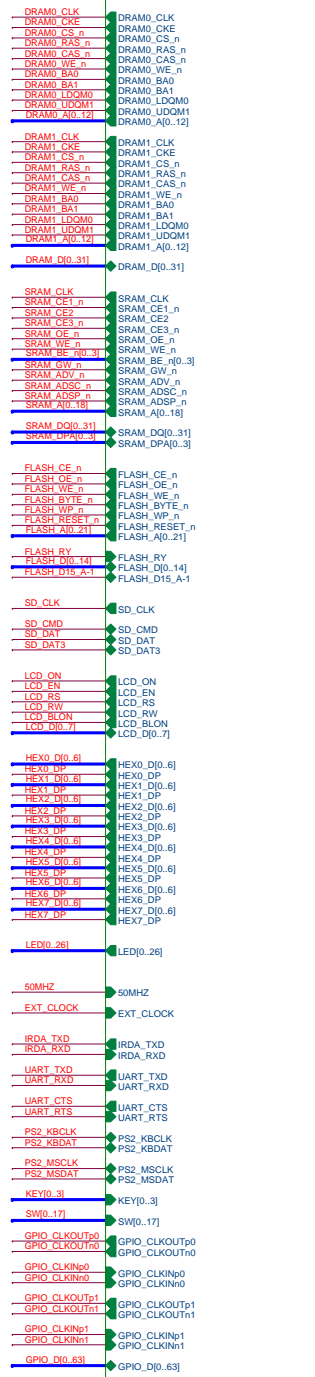
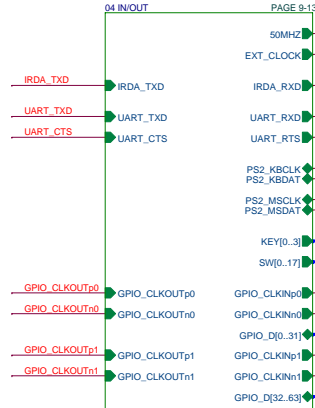
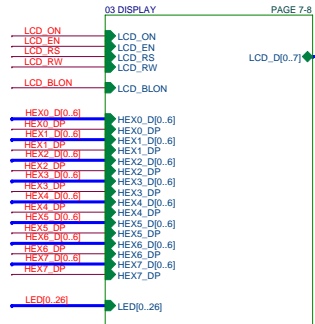
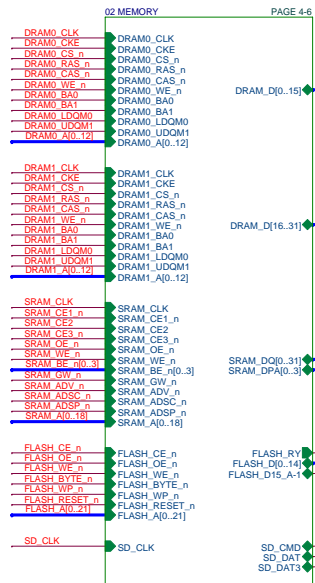

Title			ALTERA DE2-70		
Size	Document Number				Rev
B	PLACEMENT				1.0
Date:	Monday, November 26, 2007	Sheet	2	of	25

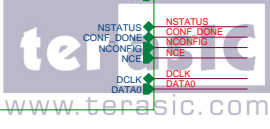

Copyright (c) 2007 by Terasic Technologies Inc. Taiwan. All rights reserved.
No part of this schematic design may be reproduced, duplicated, or used without the prior written permission of Terasic.



File	ALTERA DE2-70		
Size	Document Number	Rev	
C	TOP LEVEL	1.0	
Date:	Monday, November 26, 2007	Sheet	3 of 25

 DRAM D[0..31]
 DRAM0 A[0..12]
 DRAM1 A[0..12]

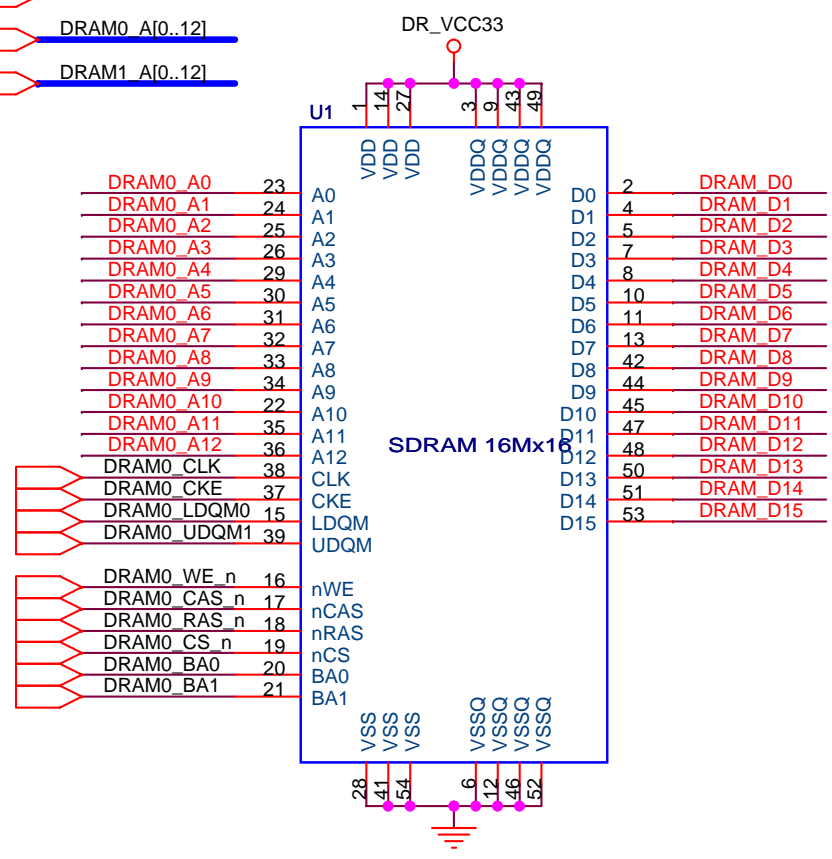

SDRAM0

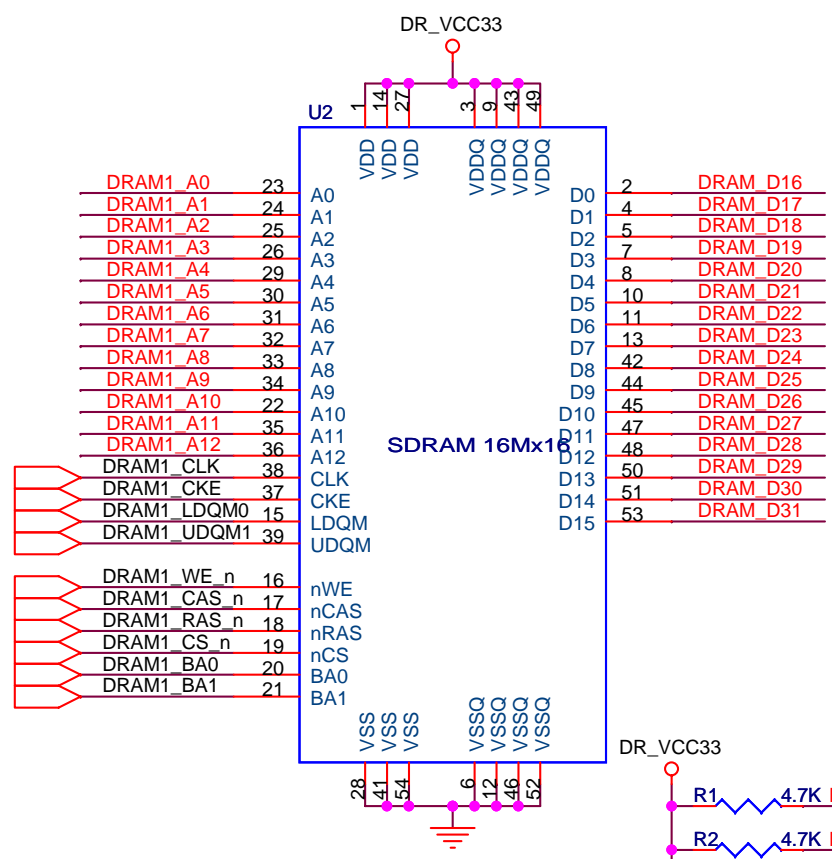

SDRAM1

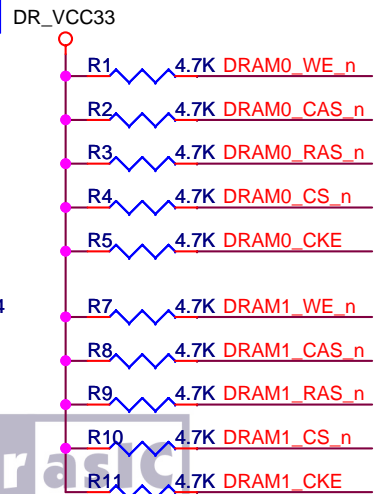
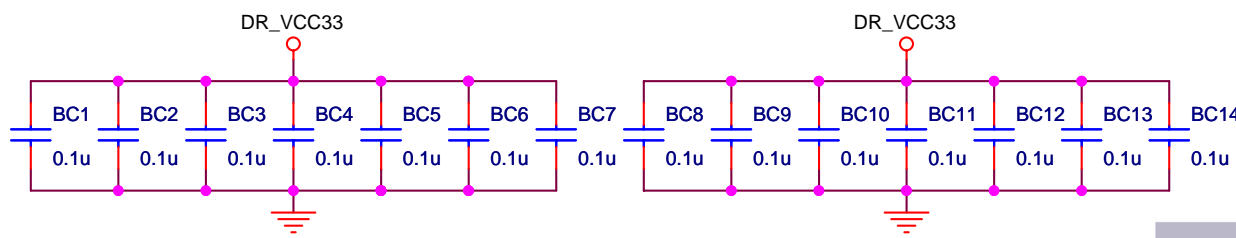
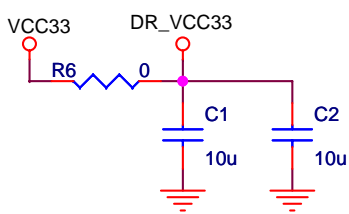

Copyright (c) 2007 by Terasic Technologies Inc. Taiwan.
All rights reserved.

No part of this schematic design may be reproduced, duplicated, or used without the prior written permission of Terasic.

Title		
ALTEA DE2-70		
Size A	Document Number SDRAM	Rev 1.0
Date:	Monday, November 26, 2007	Sheet 4 of 25

- SRAM DQ[0..31]
- SRAM DPA[0..3]
- SRAM A[0..18]
- SRAM BE_n[0..3]

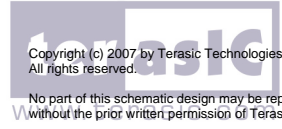
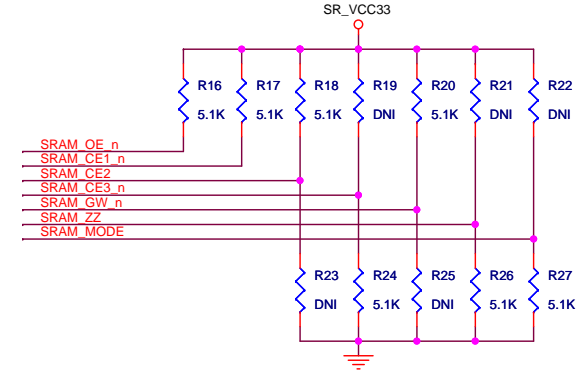
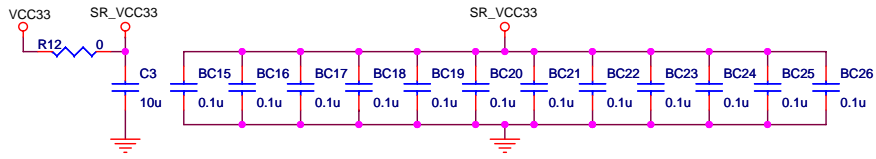
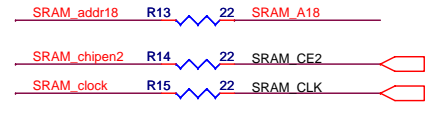
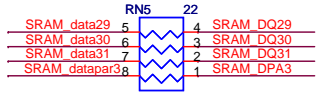
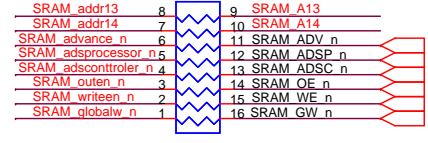
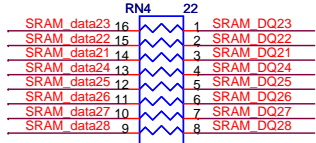
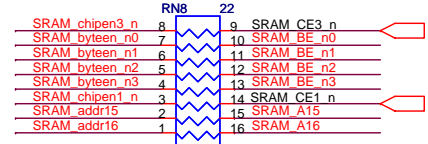
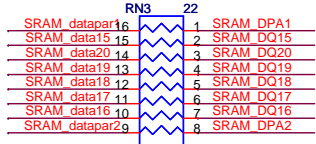
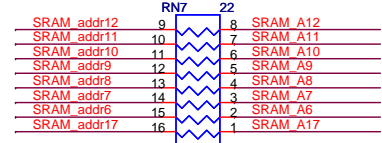
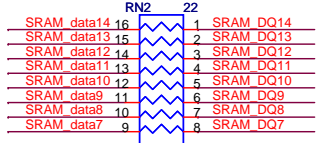
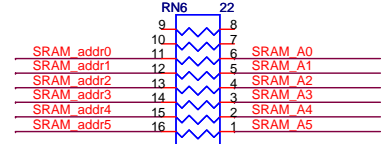
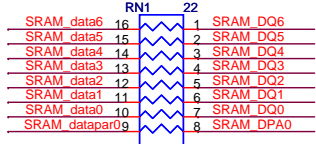
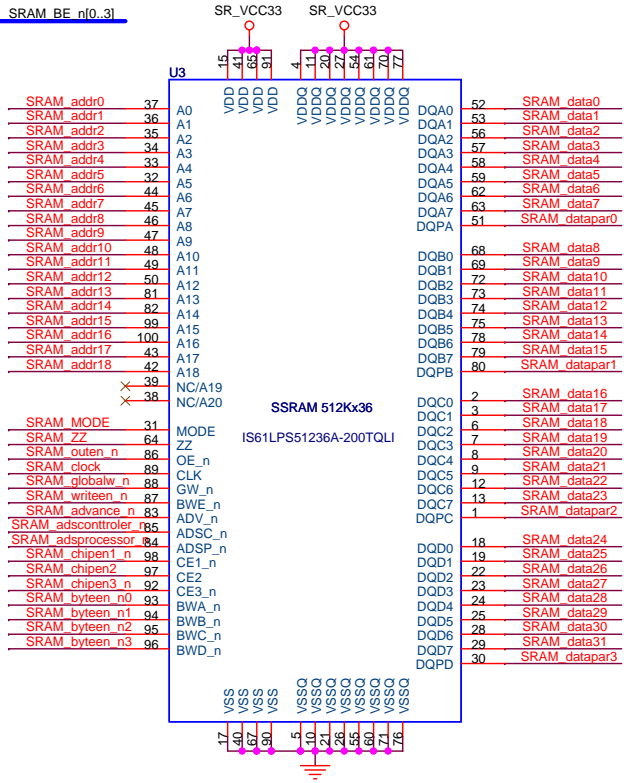

Copyright (c) 2007 by Terasic Technologies Inc. Taiwan. All rights reserved.

No part of this schematic design may be reproduced, duplicated, or used without the prior written permission of Terasic.

Title		
ALTERA DE2-70		
Size	Document Number	Rev
B	SSRAM	1.0
Date:	Monday, November 26, 2007	Sheet 5 of 25

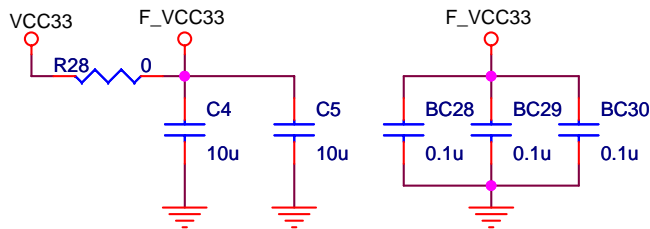
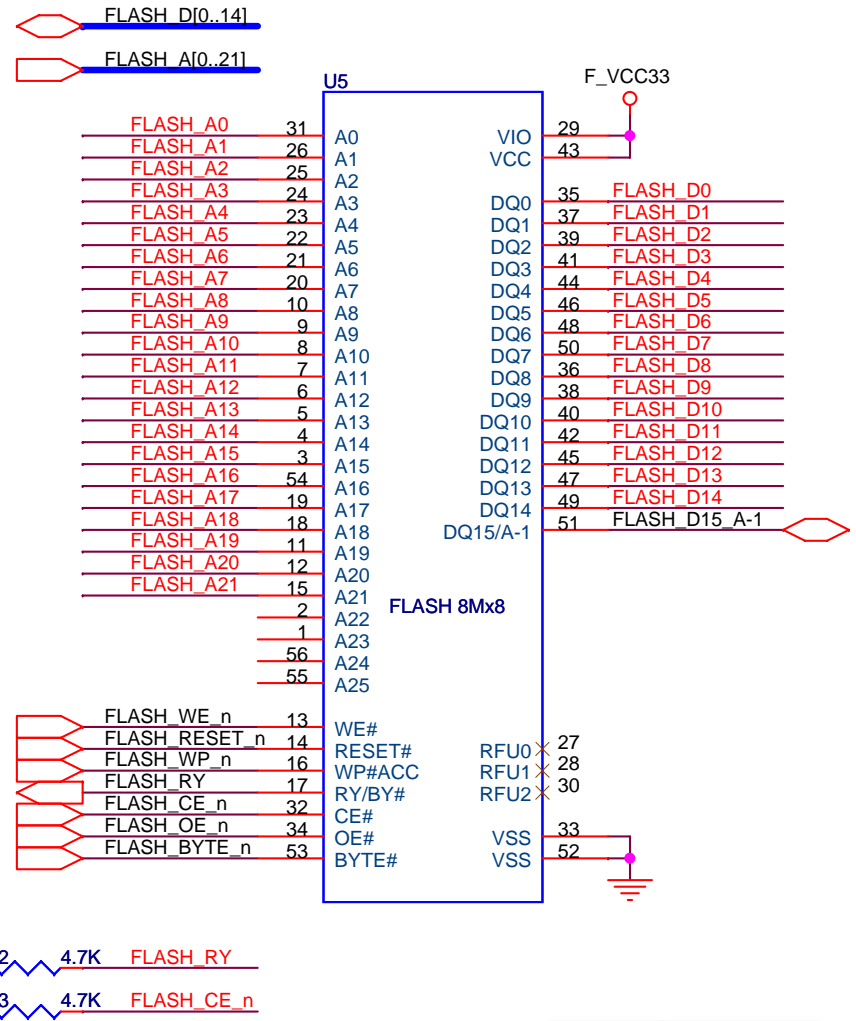
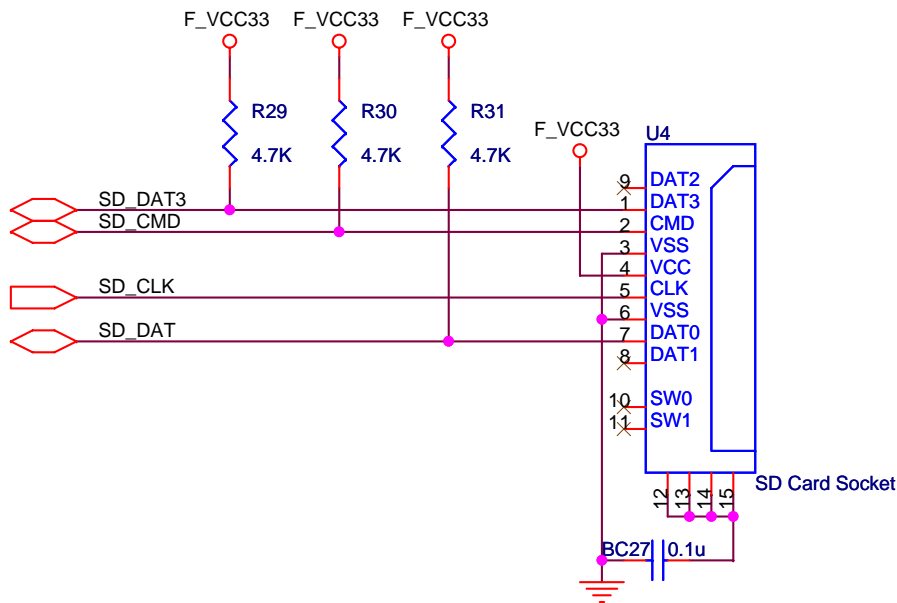

Copyright (c) 2007 by Terasic Technologies Inc. Taiwan.
All rights reserved.



No part of this schematic design may be reproduced, duplicated, or used without the prior written permission of Terasic.

Title		
ALTERA DE2-70		
Size A	Document Number FLASH and SD Card	Rev 1.0
Date:	Monday, November 26, 2007	Sheet 6 of 25

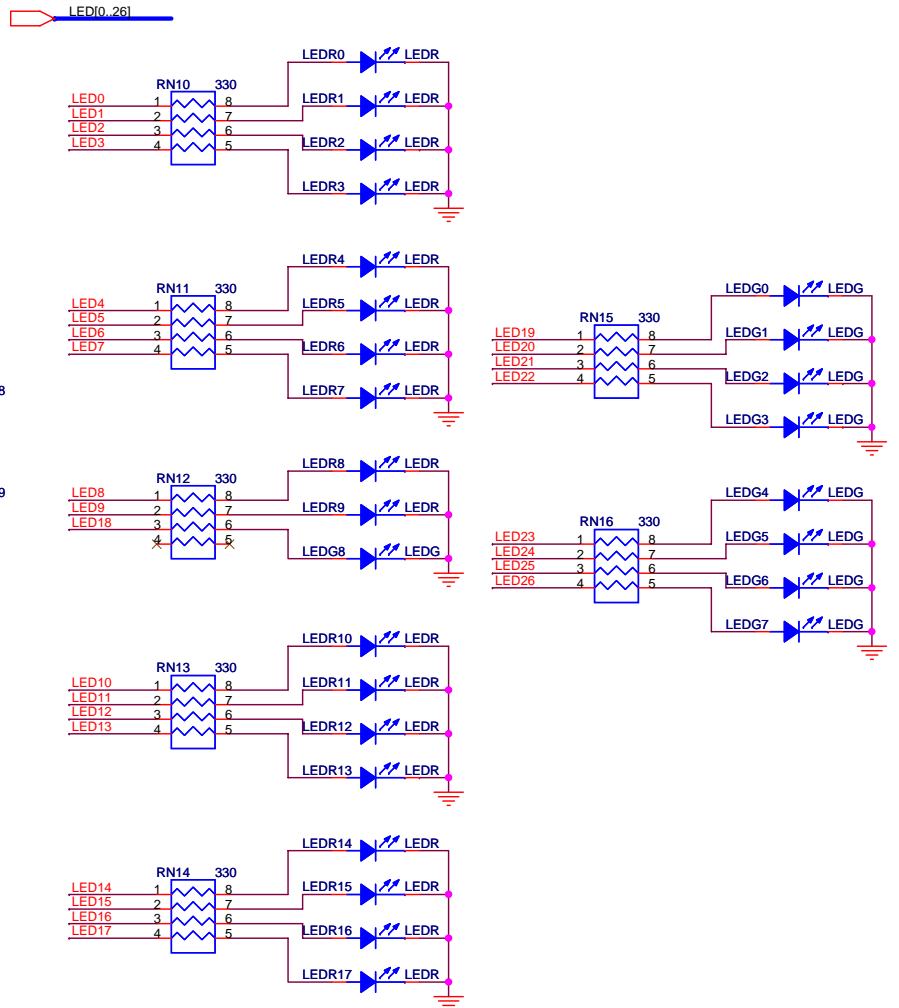
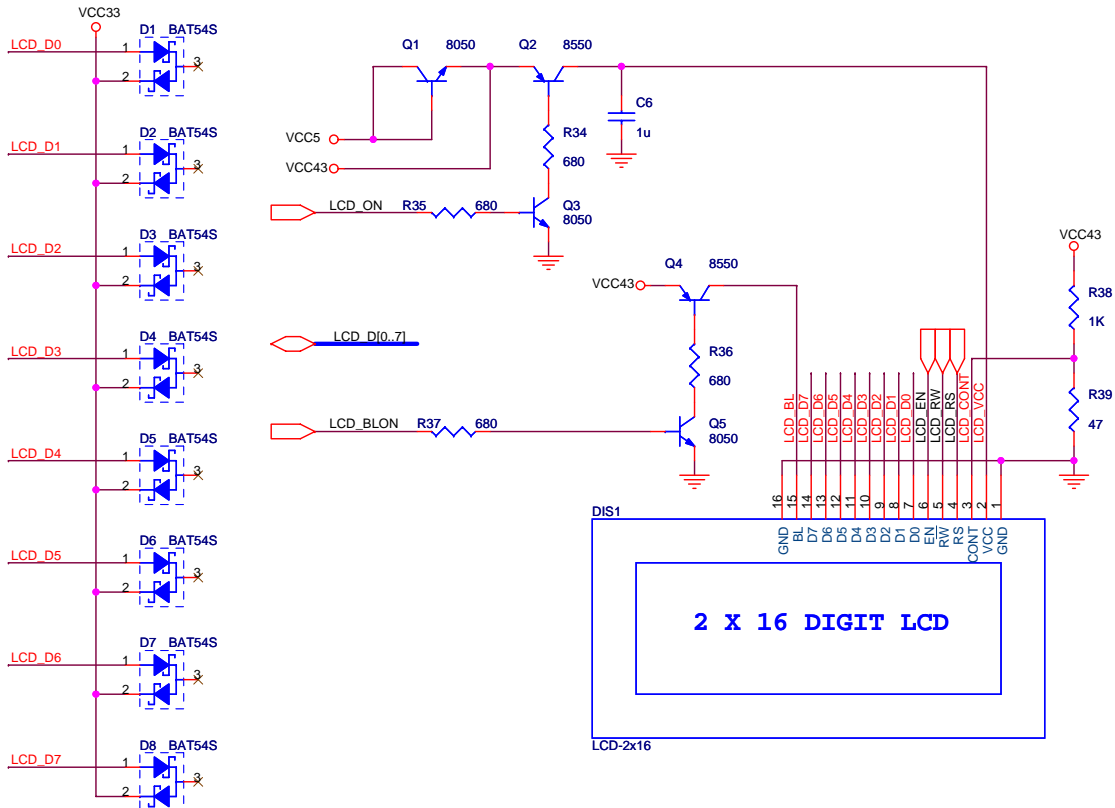

- ▶ HEX0_D[0..6]
- ▶ HEX1_D[0..6]
- ▶ HEX2_D[0..6]
- ▶ HEX3_D[0..6]
- ▶ HEX4_D[0..6]
- ▶ HEX5_D[0..6]
- ▶ HEX6_D[0..6]
- ▶ HEX7_D[0..6]

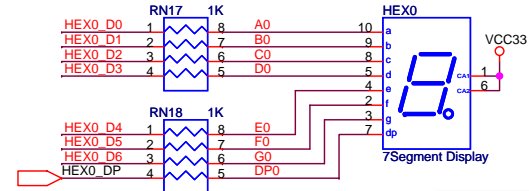
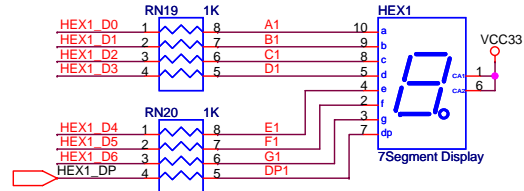
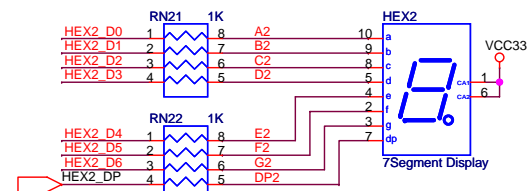
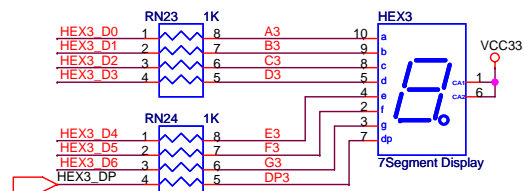
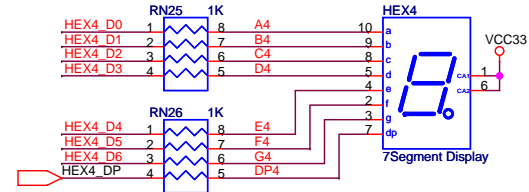
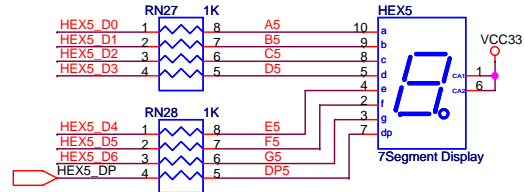
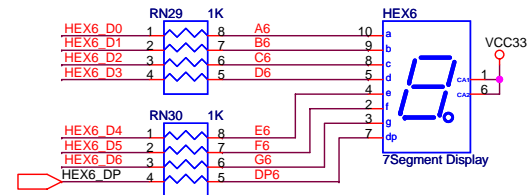
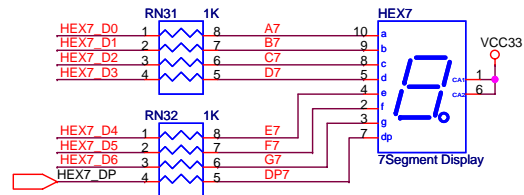

Copyright (c) 2007 by Terasic Technologies Inc. Taiwan.
 All rights reserved.
 No part of this schematic design may be reproduced, duplicated, or used
 without the prior written permission of Terasic.

Title		
ALTERA DE2-70		
Size	Document Number	Rev
B	7 SEGMENT	1.0
Date:	Monday, November 26, 2007	Sheet 8 of 25

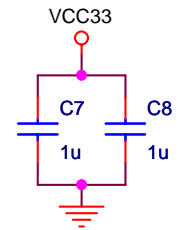
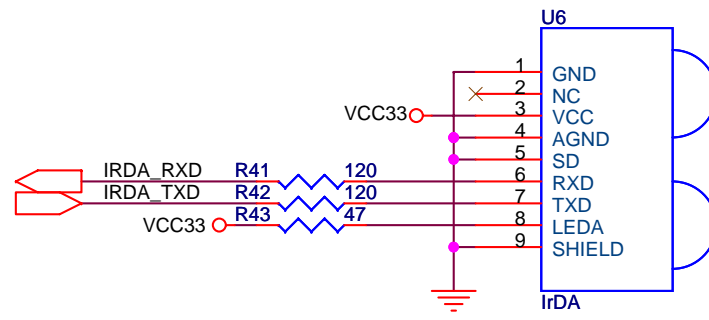
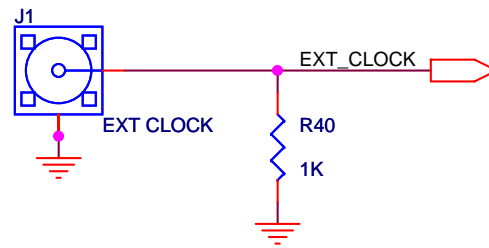
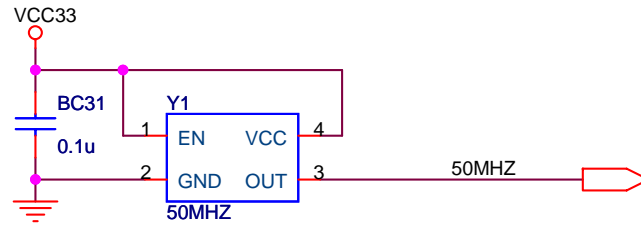

Copyright (c) 2007 by Terasic Technologies Inc. Taiwan.
All rights reserved.



No part of this schematic design may be reproduced, duplicated, or used without the prior written permission of Terasic.

Title		
ALTERA DE2-70		
Size A	Document Number CLOCK and IrDA	Rev 1.0
Date:	Monday, November 26, 2007	Sheet 9 of 25

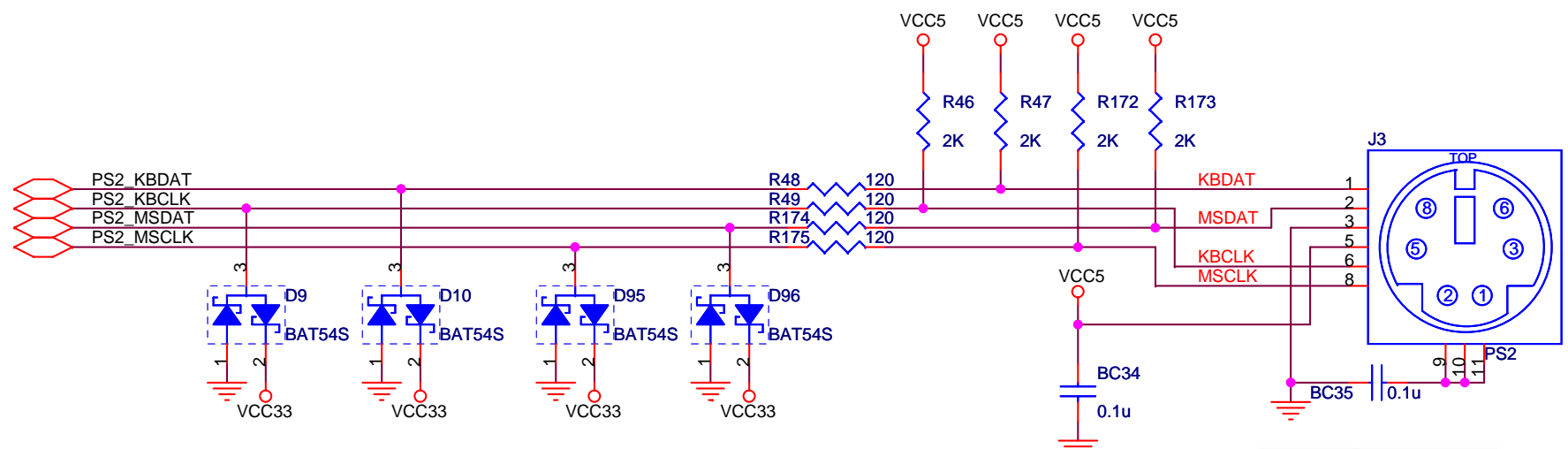
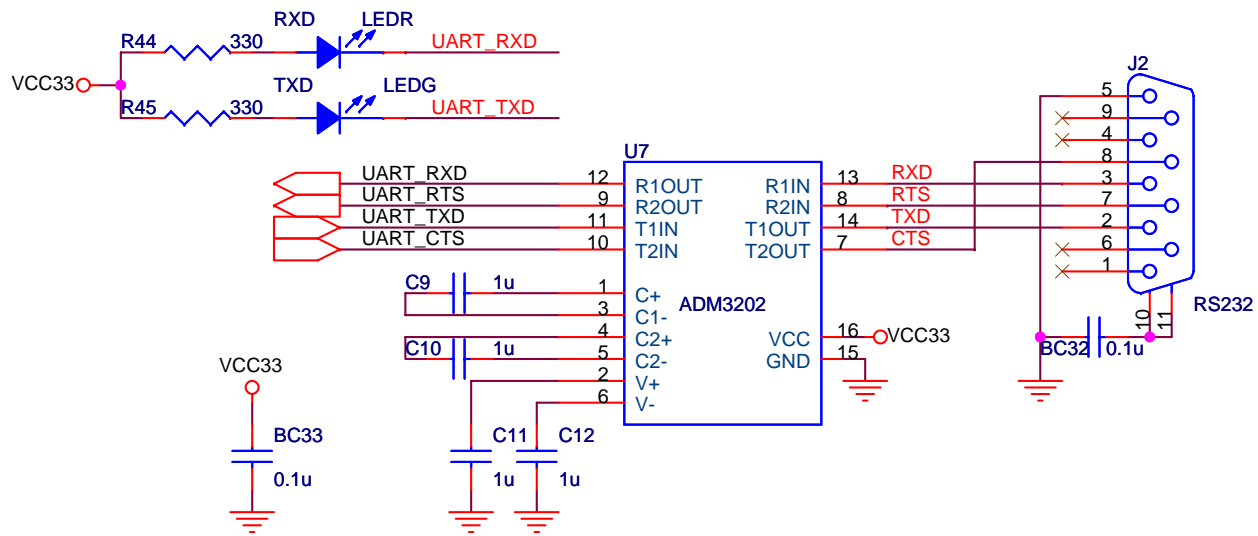

Copyright (c) 2007 by Terasic Technologies Inc. Taiwan.
All rights reserved.



No part of this schematic design may be reproduced, duplicated, or used without the prior written permission of Terasic.

Title		
ALTERA DE2-70		
Size	Document Number	Rev
A	PS2 AND RS232	1.0
Date:	Monday, November 26, 2007	Sheet 10 of 25

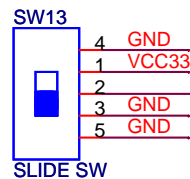
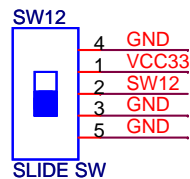
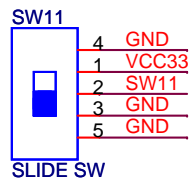
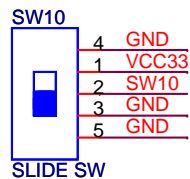
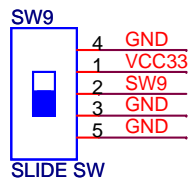
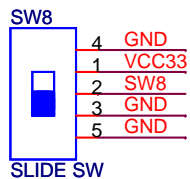
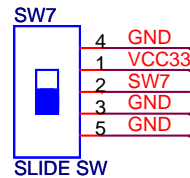
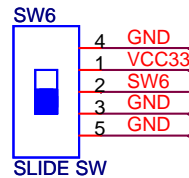
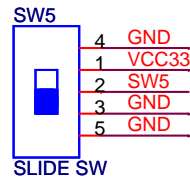
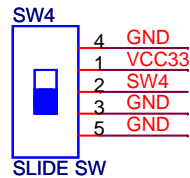
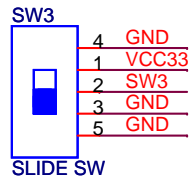
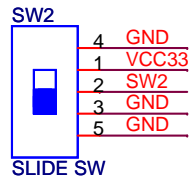
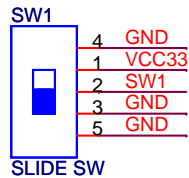
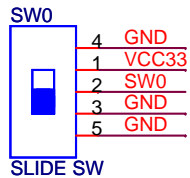
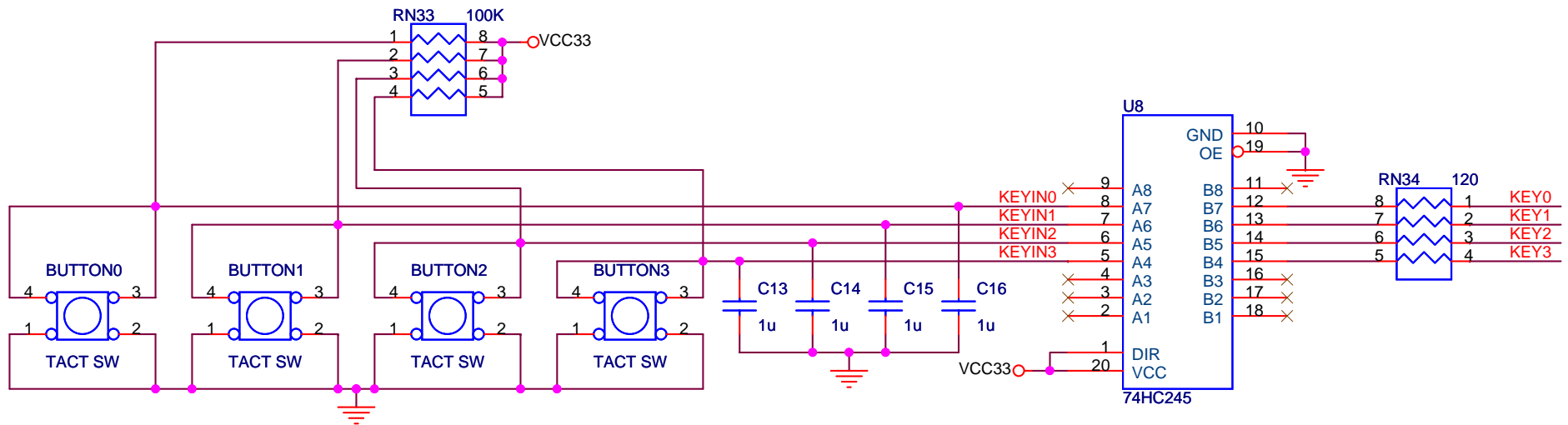

R50 120 SW13

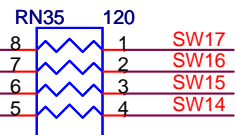
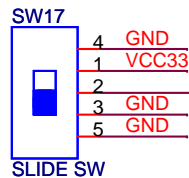
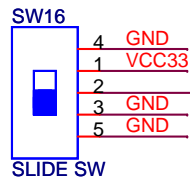
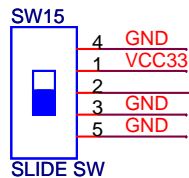
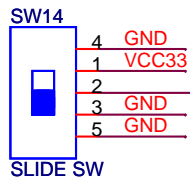

KEY[0..3]
SW[0..17]



Copyright (c) 2007 by Terasic Technologies Inc. Taiwan.
All rights reserved.

No part of this schematic design may be reproduced, duplicated, or used
without the prior written permission of Terasic.

Title		
ALTEA DE2-70		
Size A	Document Number KEY AND SWITCH	Rev 1.0
Date:	Monday, November 26, 2007	Sheet 11 of 25

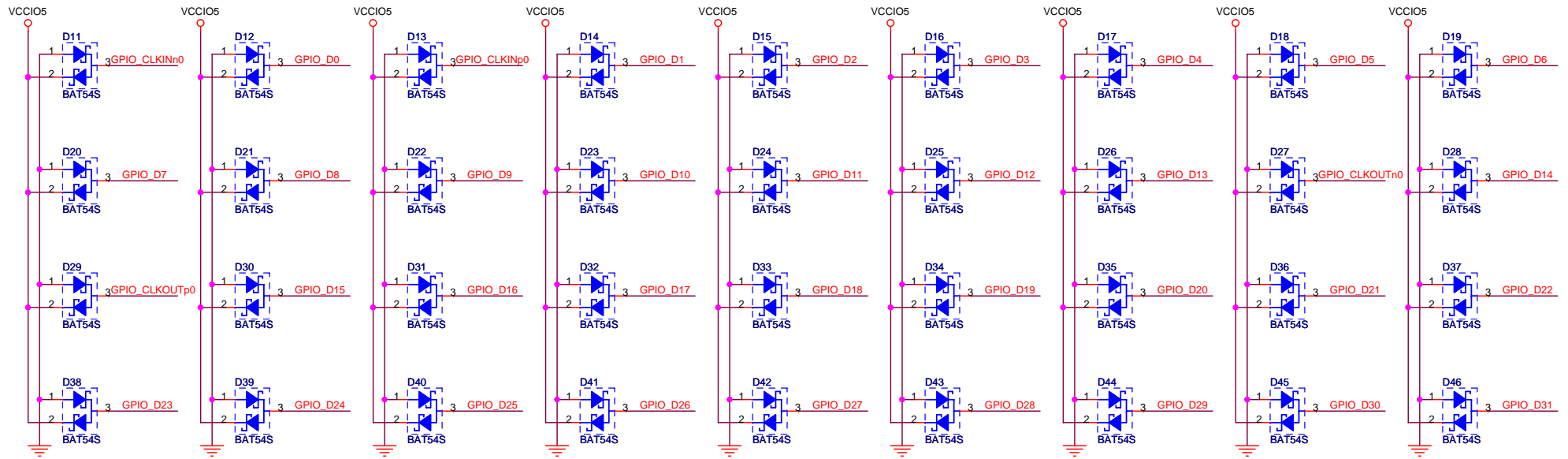

GPIO_D10..31

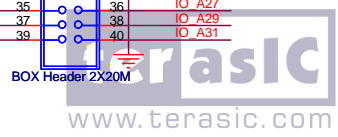
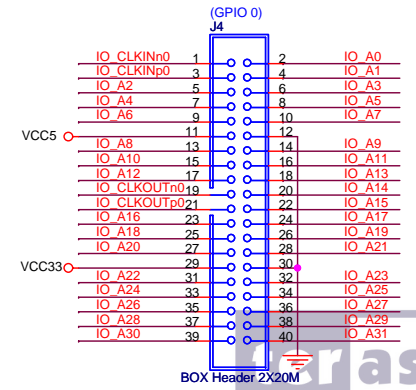
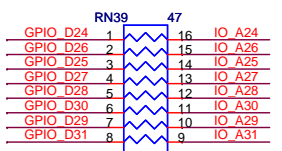
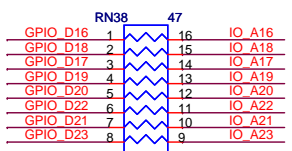
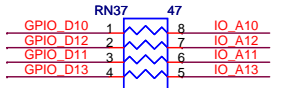
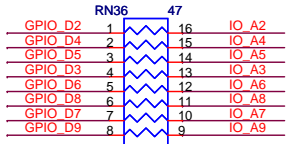
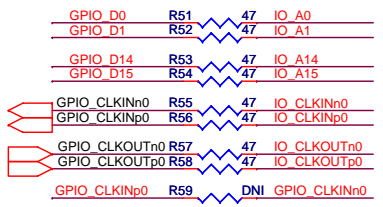

Copyright (c) 2007 by Terasic Technologies Inc. Taiwan. All rights reserved.

No part of this schematic design may be reproduced, duplicated, or used without the prior written permission of Terasic.

Title			ALTERA DE2-70		
Size	Document Number	Rev			
B	CONNECT A	1.0			
Date:	Monday, November 26, 2007	Sheet	12	of	25

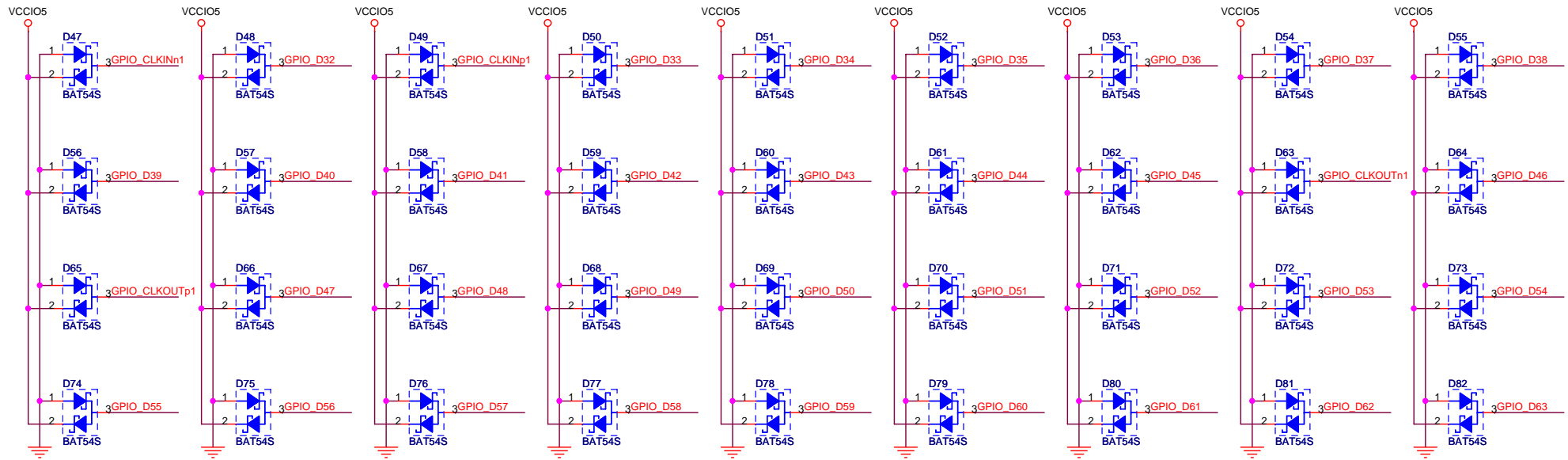

GPIO D[32..63]

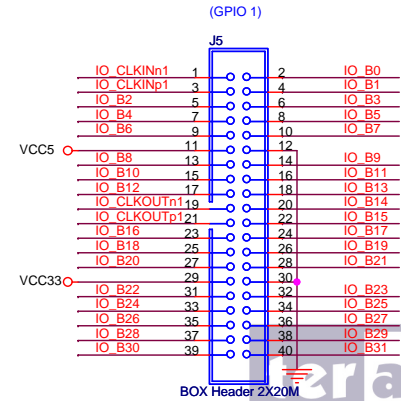
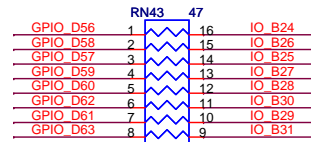
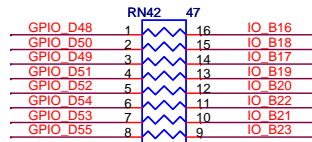
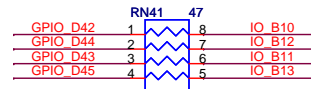
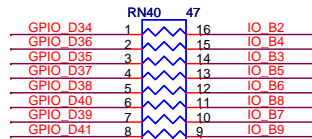
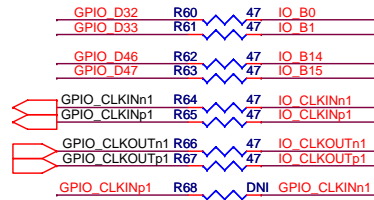

Copyright (c) 2007 by Terasic Technologies Inc. Taiwan. All rights reserved.

No part of this schematic design may be reproduced, duplicated, or used without the prior written permission of Terasic.

Title			ALTERA DE2-70		
Size	Document Number		CONNECT B		Rev
B					1.0
Date:	Monday, November 26, 2007	Sheet	13	of	25

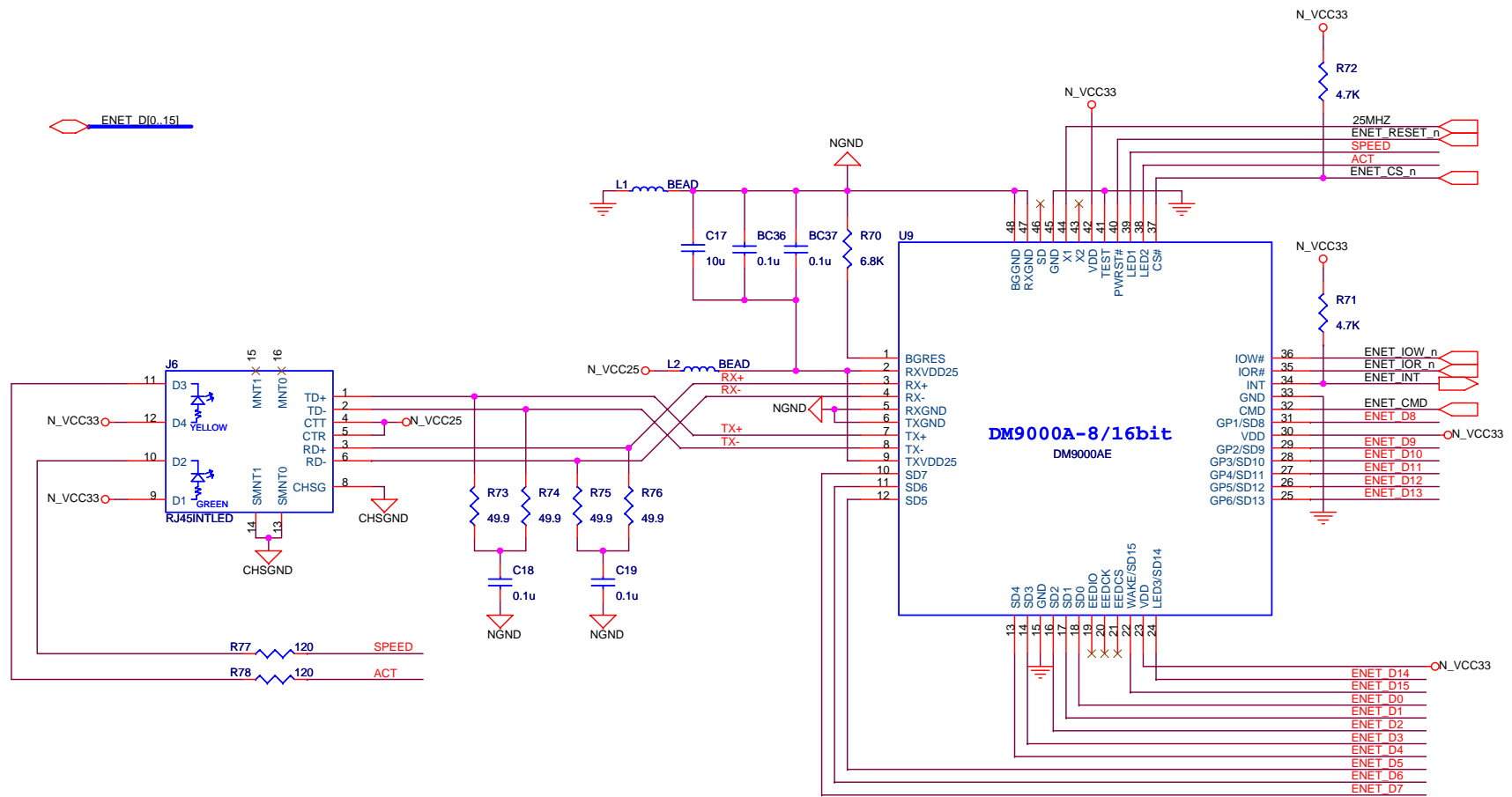

ENET_D0..15

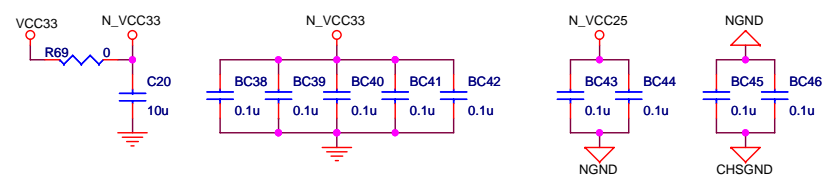

Copyright (c) 2007 by Terasic Technologies Inc. Taiwan. All rights reserved.

No part of this schematic design may be reproduced, duplicated, or used without the prior written permission of Terasic.

Title		
ALTERA DE2-70		
Size	Document Number	Rev
B	DM9000AE	1.0
Date:	Monday, November 26, 2007	Sheet 14 of 25

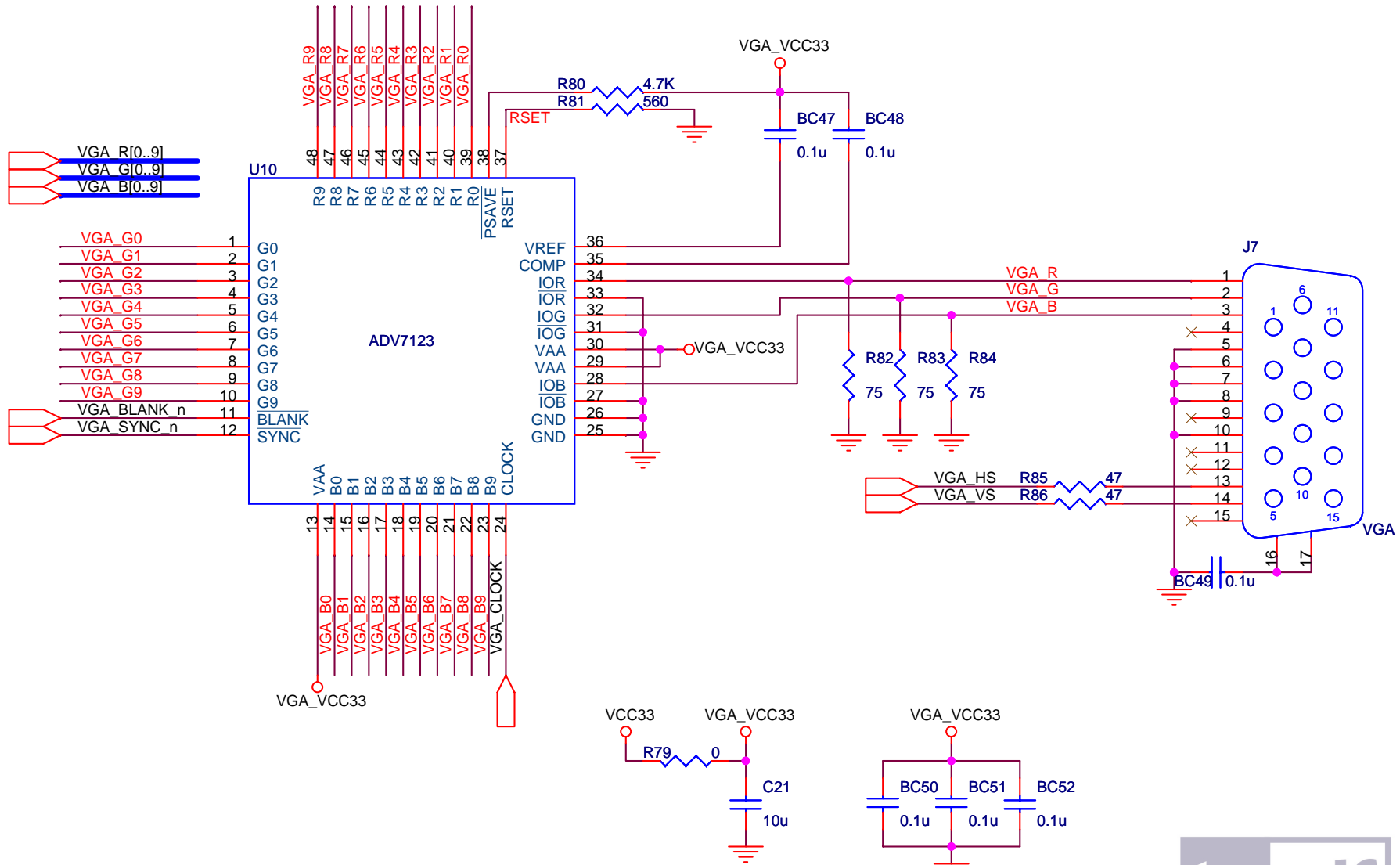

Copyright (c) 2007 by Terasic Technologies Inc. Taiwan.
All rights reserved.

No part of this schematic design may be reproduced, duplicated, or used
without the prior written permission of Terasic.

Title		
ALTEA DE2-70		
Size	Document Number	Rev
A	ADV7123	1.0
Date:	Monday, November 26, 2007	Sheet 15 of 25

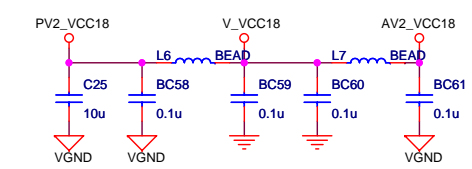
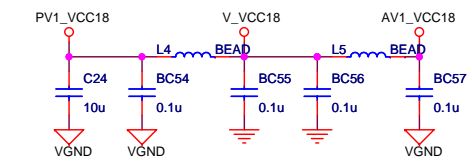
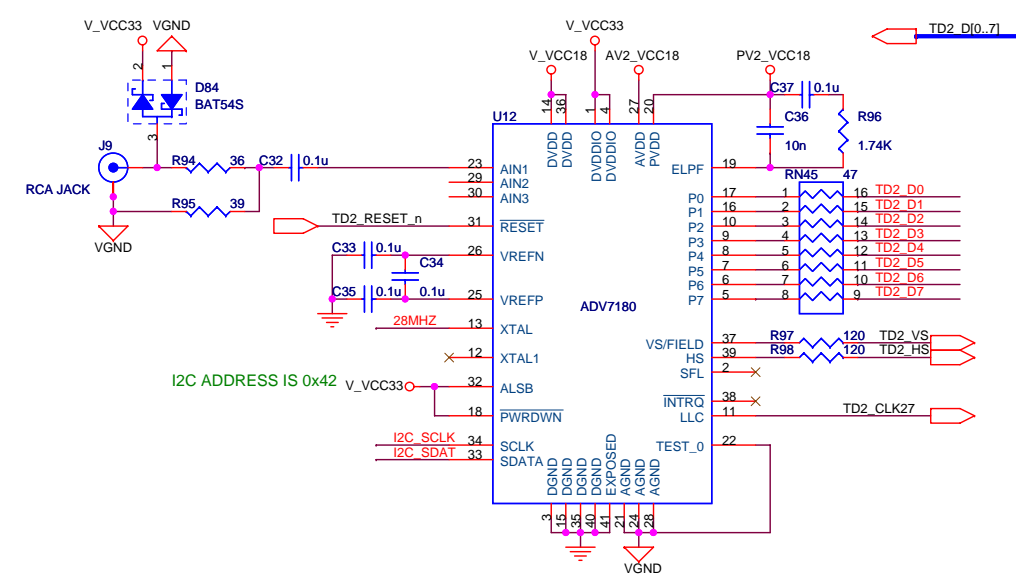
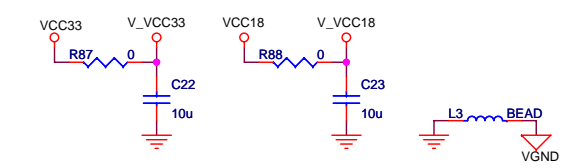
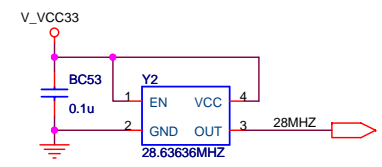
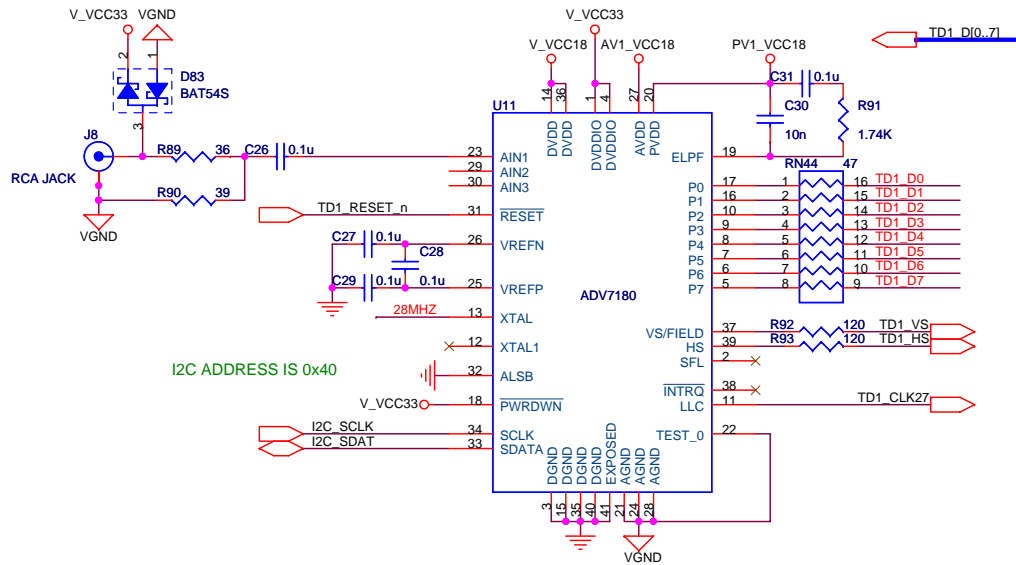

Copyright (c) 2007 by Terasic Technologies Inc. Taiwan. All rights reserved.

No part of this schematic design may be reproduced, duplicated, or used without the prior written permission of Terasic.

Title			ALTERA DE2-70		
Size	Document Number				Rev
B	ADV7180				1.0
Date:	Monday, November 26, 2007	Sheet	16	of	25

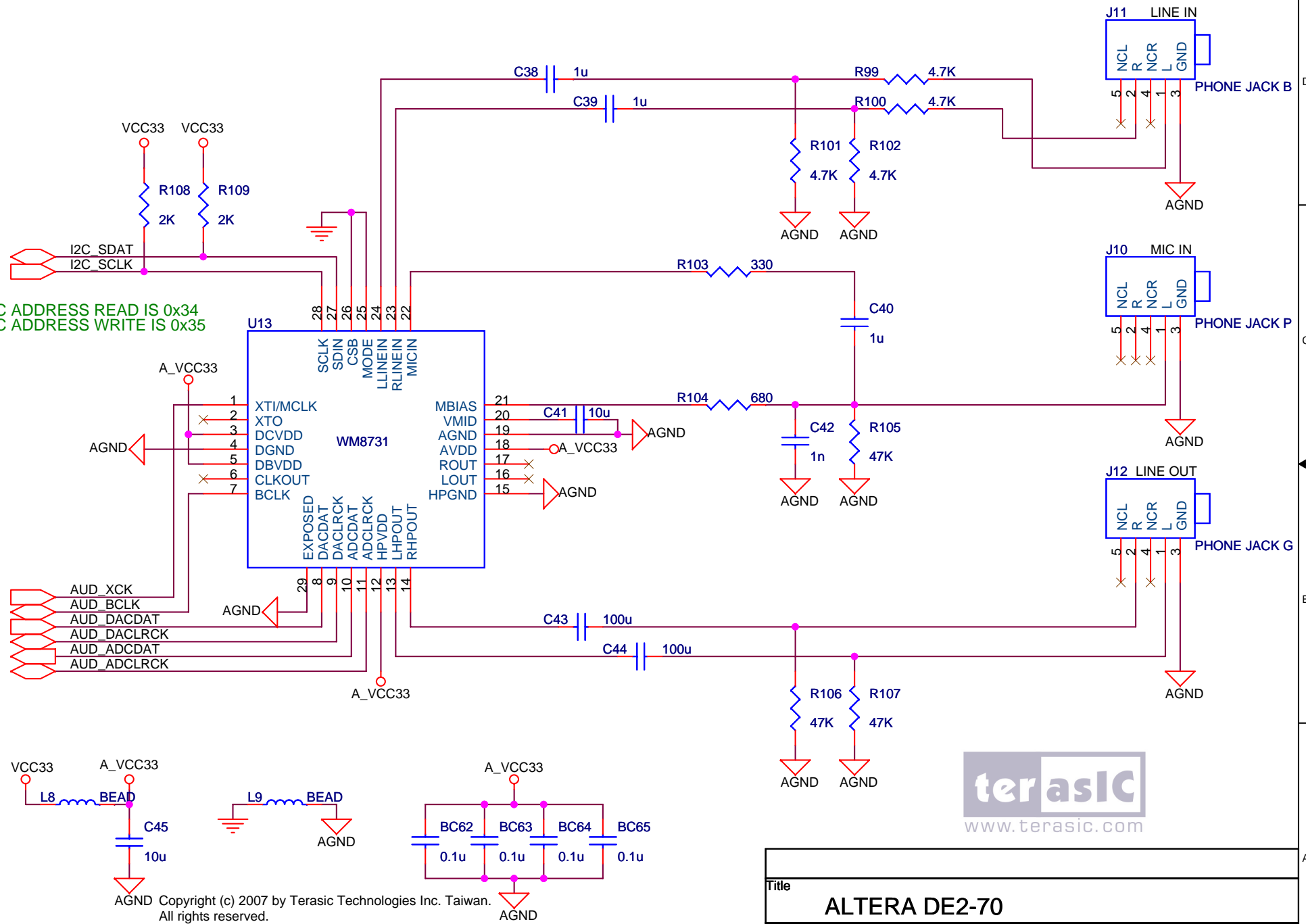

I2C ADDRESS READ IS 0x34
I2C ADDRESS WRITE IS 0x35



AGND Copyright (c) 2007 by Terasic Technologies Inc. Taiwan.
All rights reserved.

No part of this schematic design may be reproduced, duplicated, or used
without the prior written permission of Terasic.

Title		
ALTERA DE2-70		
Size A	Document Number AUDIO	Rev 1.0
Date:	Monday, November 26, 2007	Sheet 17 of 25

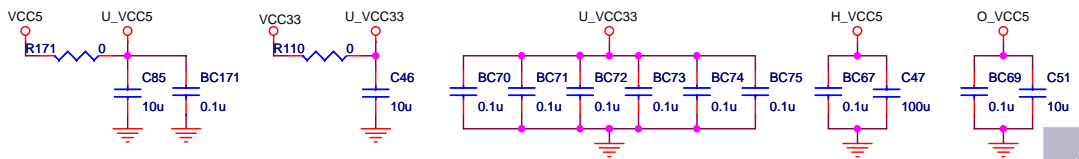
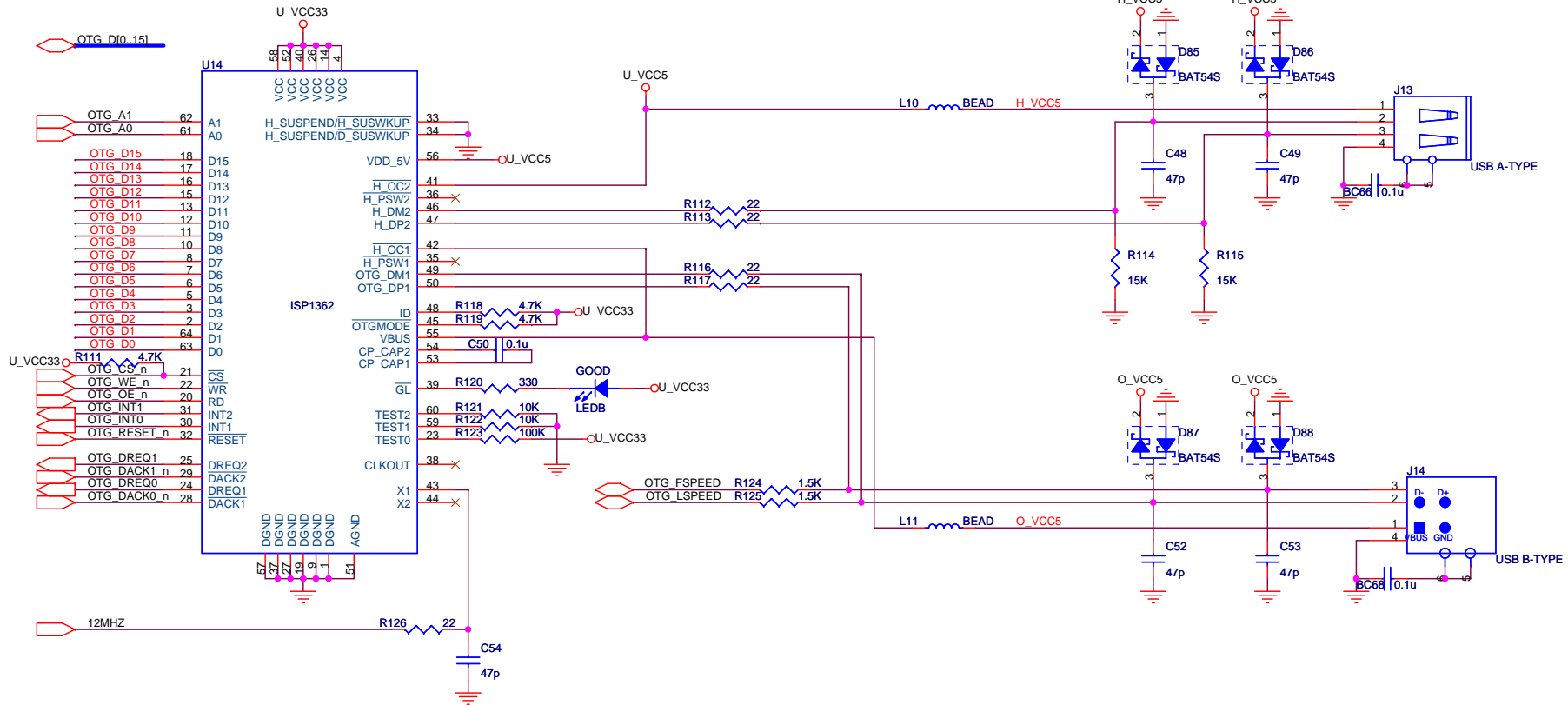

Copyright (c) 2007 by Terasic Technologies Inc. Taiwan. All rights reserved.

No part of this schematic design may be reproduced, duplicated, or used without the prior written permission of Terasic.

Title		
ALTEA DE2-70		
Size	Document Number	Rev
B	ISP 1362	1.0
Date:	Monday, November 26, 2007	Sheet 18 of 25

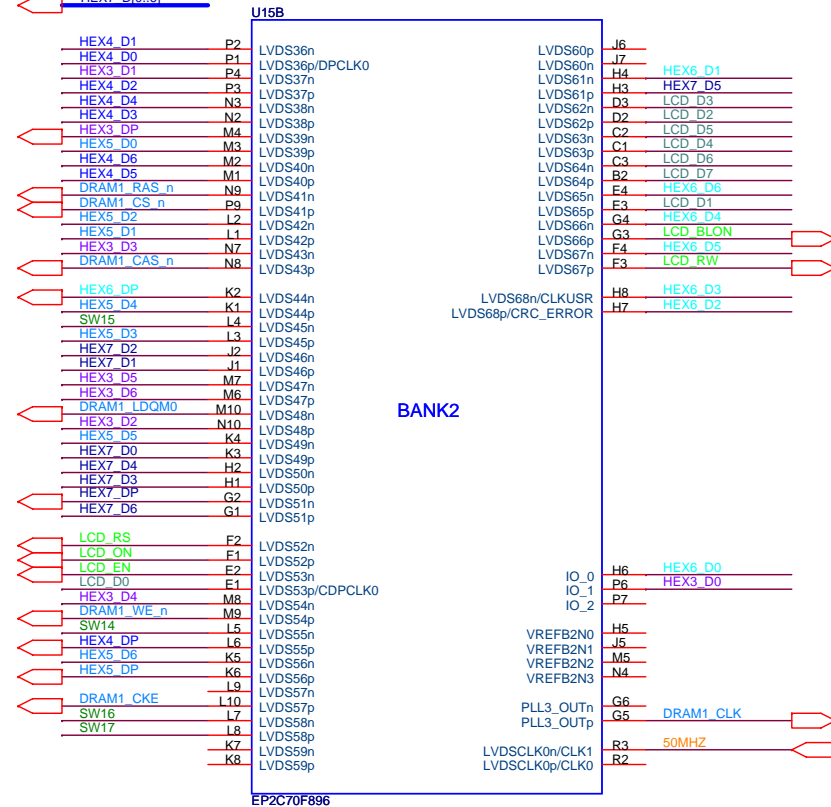
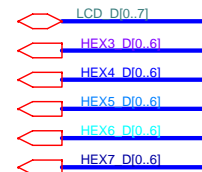
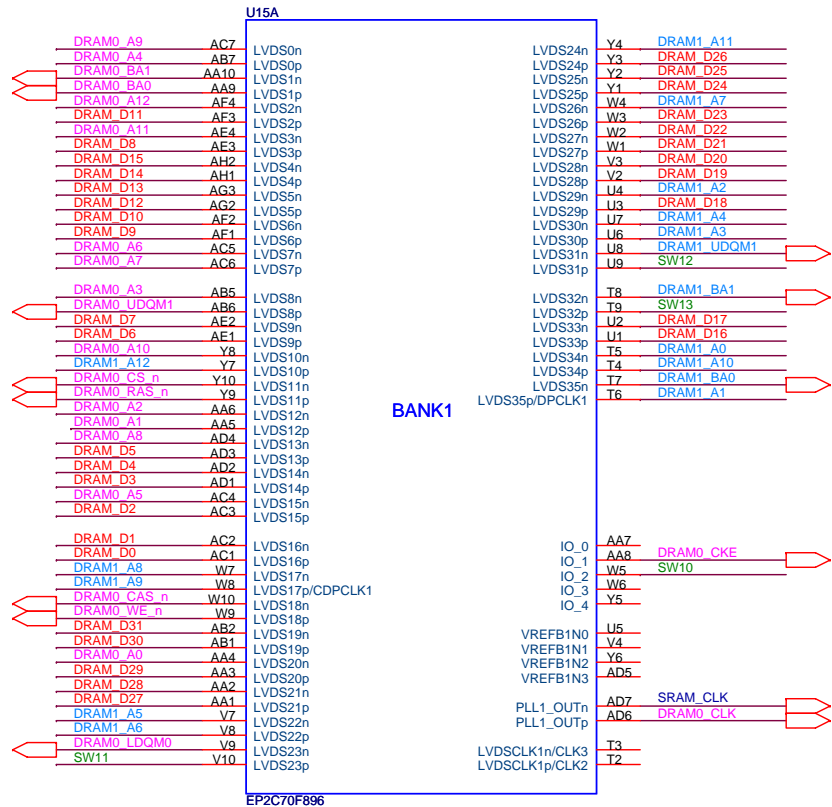
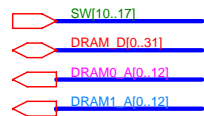

terasic
 Copyright (c) 2007 by Terasic Technologies Inc. Taiwan.
 All rights reserved.
 No part of this schematic design may be reproduced, duplicated, or used without the prior written permission of Terasic.

Title		
ALTERA DE2-70		
Size	Document Number	Rev
B	EP2C70 BANK1 AND BANK 2	1.0
Date:	Monday, November 26, 2007	Sheet 19 of 25

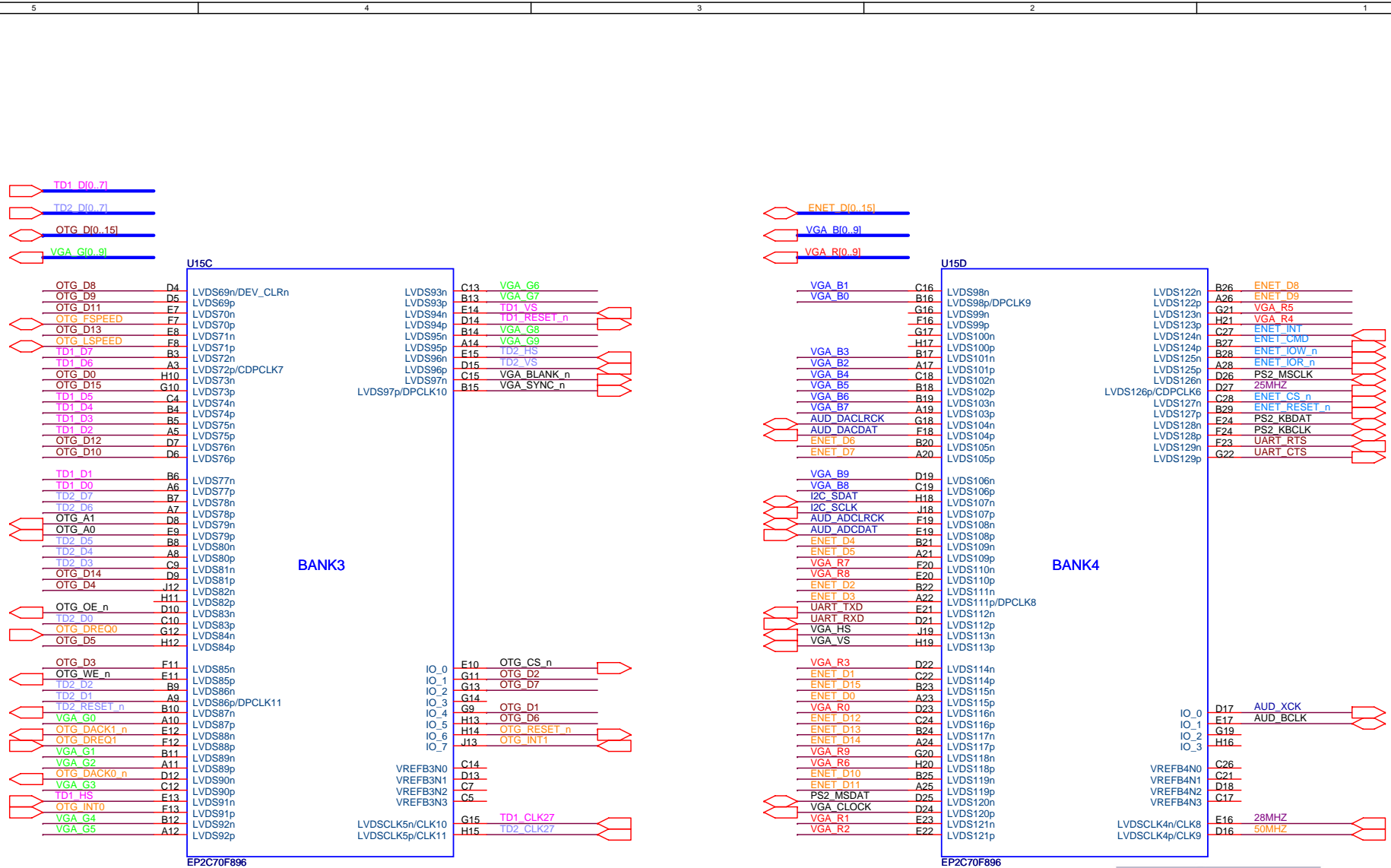

Copyright (c) 2007 by Terasic Technologies Inc. Taiwan. All rights reserved.

No part of this schematic design may be reproduced, duplicated, or used without the prior written permission of Terasic.

Title			ALTERA DE2-70		
Size	Document Number	Rev			
B	EP2C70 BANK3 AND BANK 4	1.0			
Date:	Monday, November 26, 2007	Sheet	20	of	25

5

4

3

2

1

GPIODI0_63i

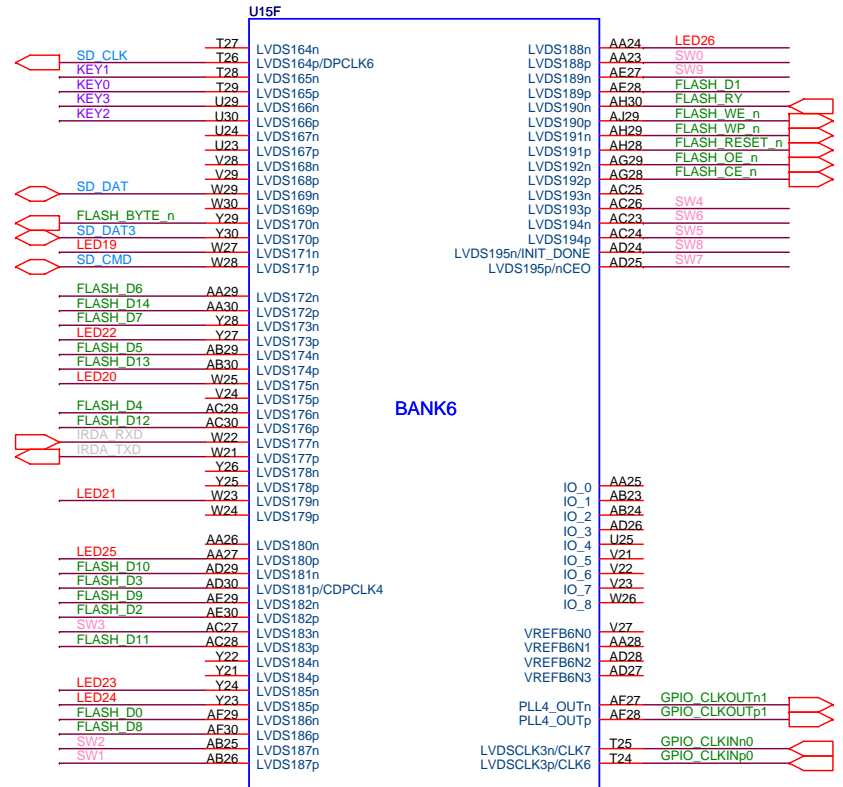
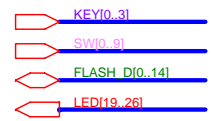
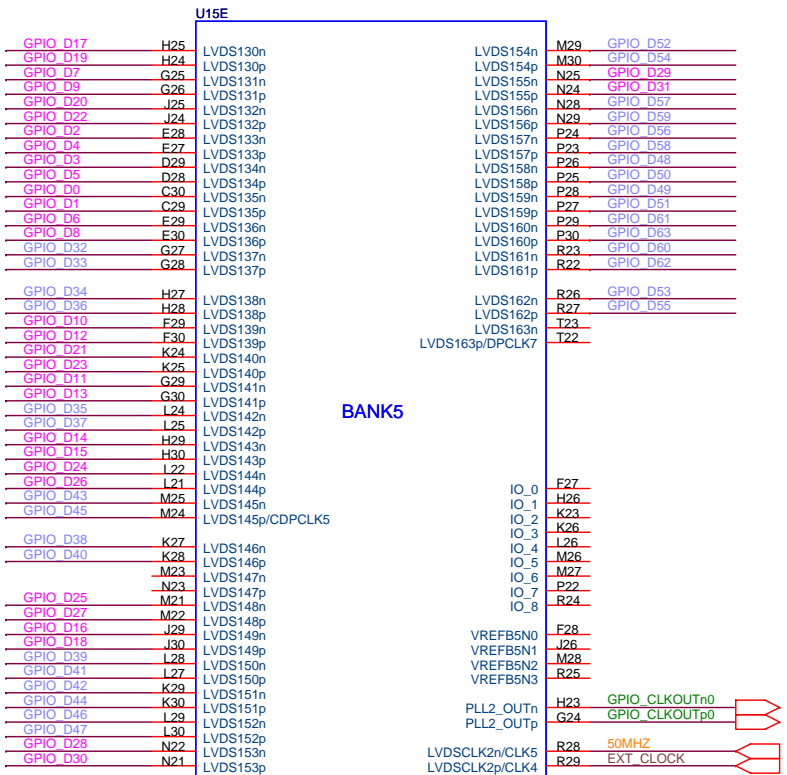

Copyright (c) 2007 by Terasic Technologies Inc. Taiwan. All rights reserved.

No part of this schematic design may be reproduced, duplicated, or used without the prior written permission of Terasic.

Title		
ALTERA DE2-70		
Size	Document Number	Rev
B	EP2C70 BANKS AND BANK 6	1.0
Date:	Monday, November 26, 2007	Sheet 21 of 25

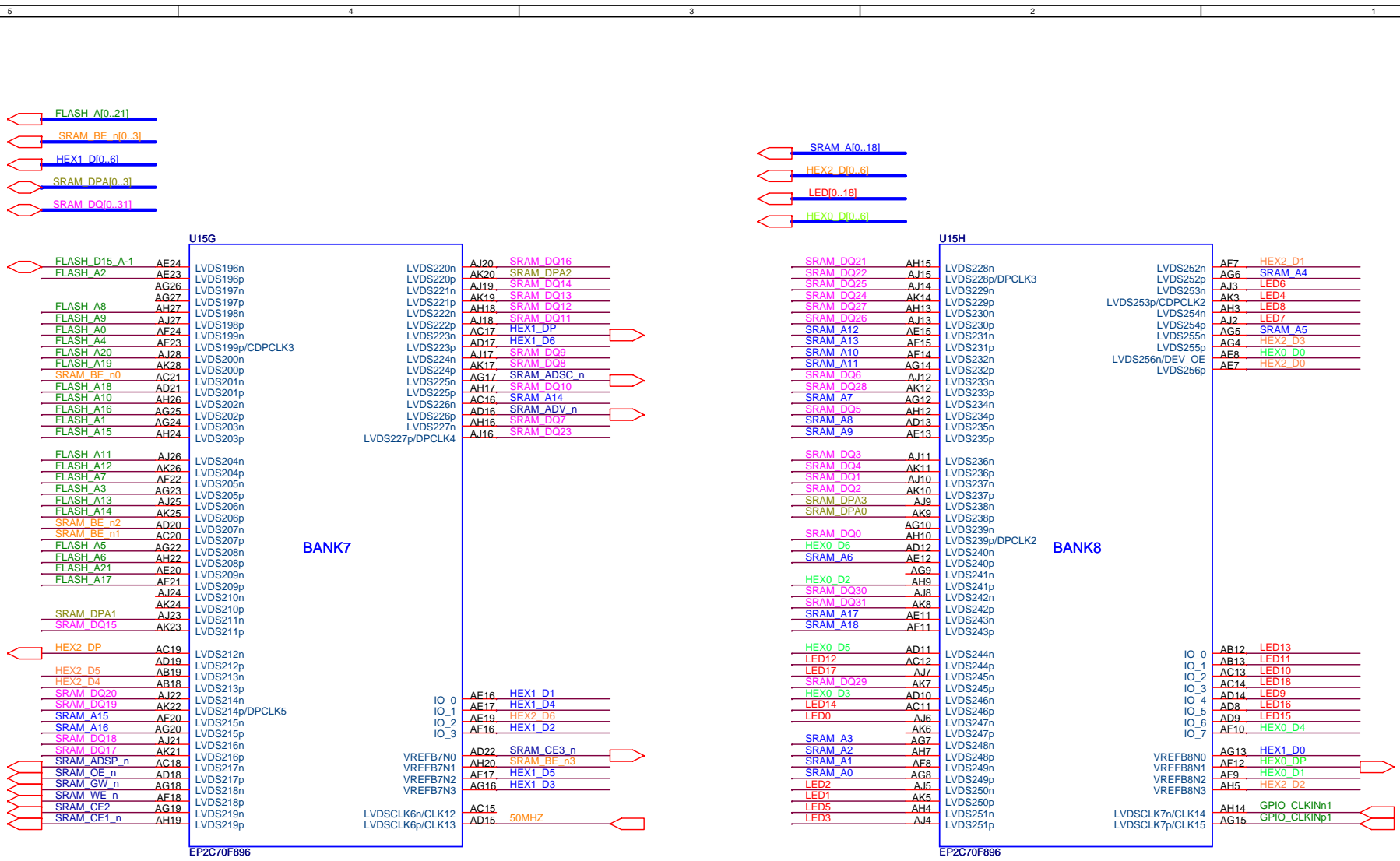



 Copyright (c) 2007 by Terasic Technologies Inc. Taiwan. All rights reserved.

 No part of this schematic design may be reproduced, duplicated, or used without the prior written permission of Terasic.

Title		
ALTEA DE2-70		
Size	Document Number	Rev
B	EP2C70 BANK7 AND BANK 8	1.0
Date:	Monday, November 26, 2007	Sheet 22 of 25

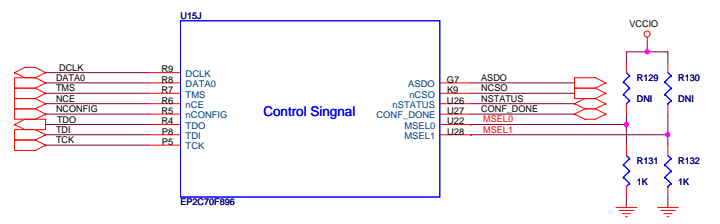
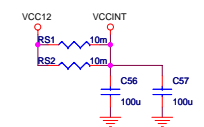
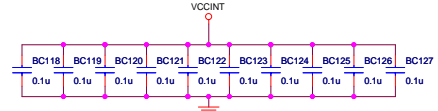
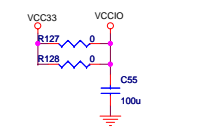
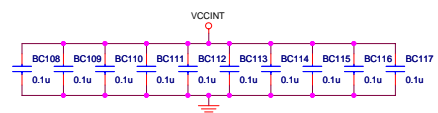
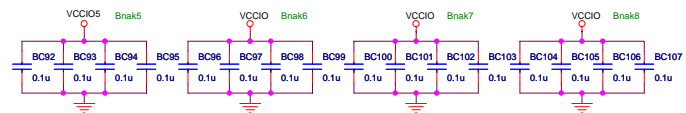
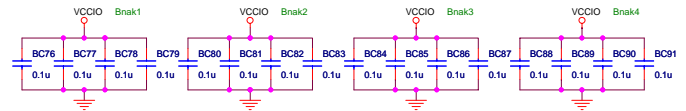
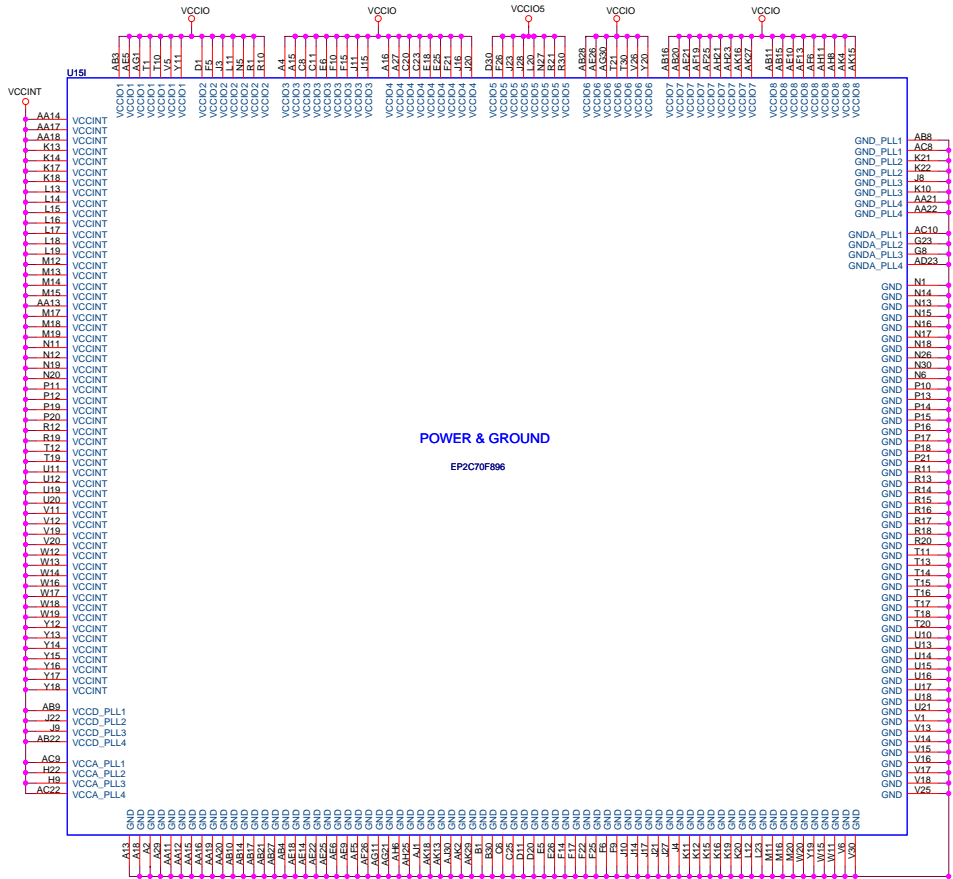

Copyright (c) 2007 by Terasic Technologies Inc. Taiwan.
All rights reserved.

No part of this schematic design may be reproduced, duplicated, or used without the prior written permission of Terasic.

Title		ALTERA DE2-70	
Size	C	Document Number	EP2C70 POWER AND CONFIG
Date:	Monday, November 26, 2007	Sheet	23 of 25
Rev	1.0		

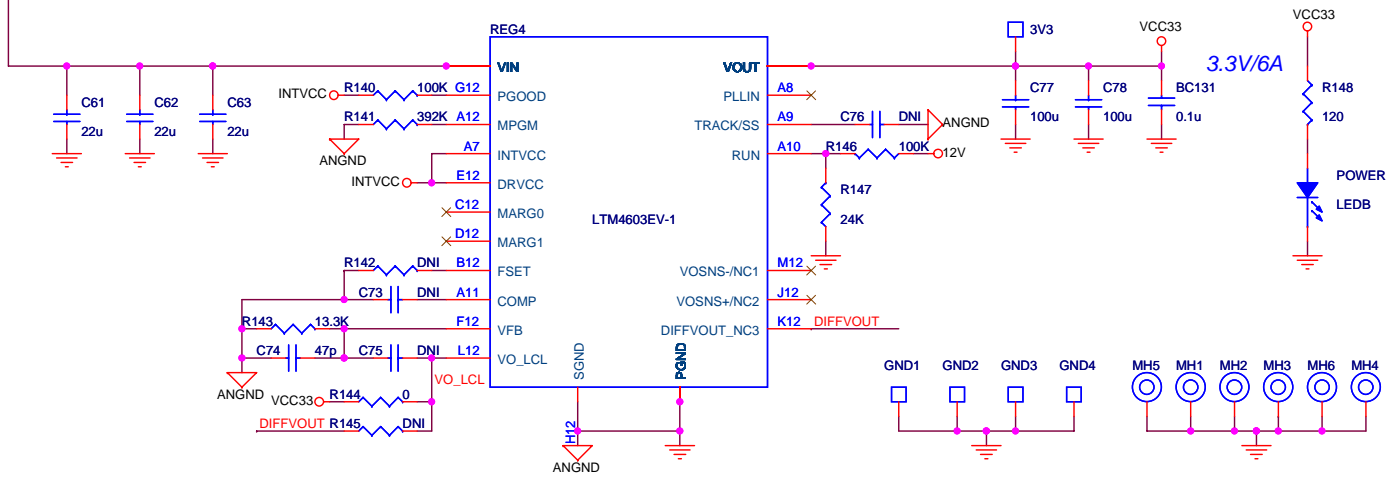
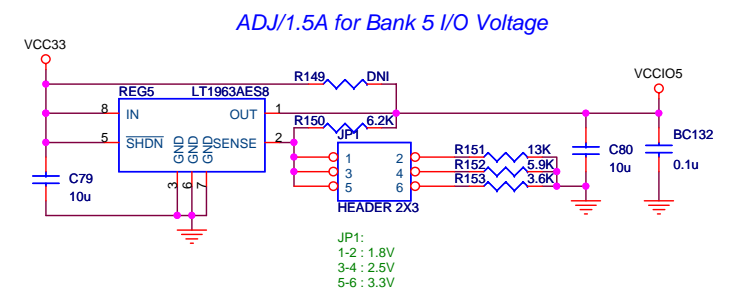
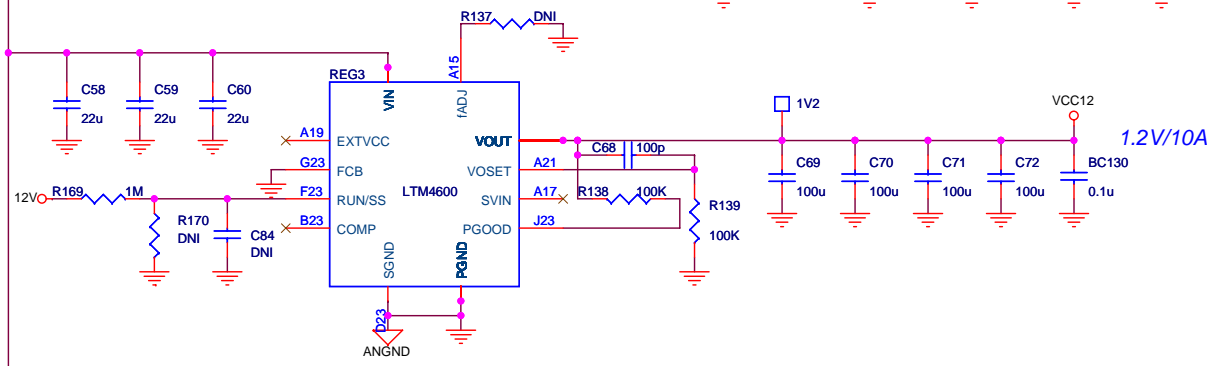
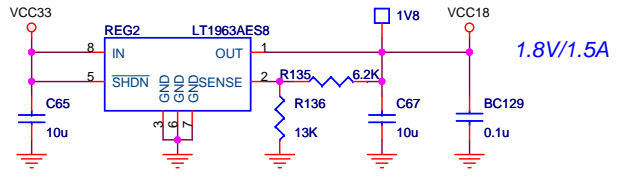
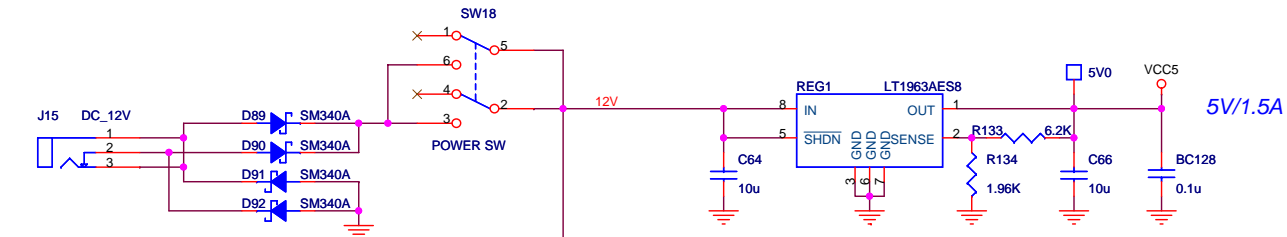

ADJ/1.5A for Bank 5 I/O Voltage

Copyright (c) 2007 by Terasic Technologies Inc. Taiwan.
 All rights reserved.
 No part of this schematic design may be reproduced, duplicated, or used without the prior written permission of Terasic.

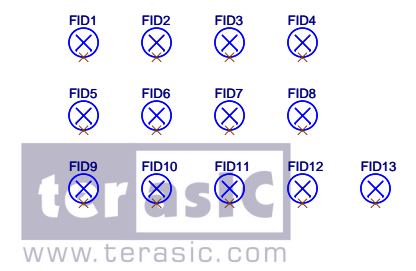

Title			ALTERA DE2-70		
Size	Document Number	Rev			
	POWER	1.0			
Date:	Monday, November 26, 2007	Sheet	24	of	25

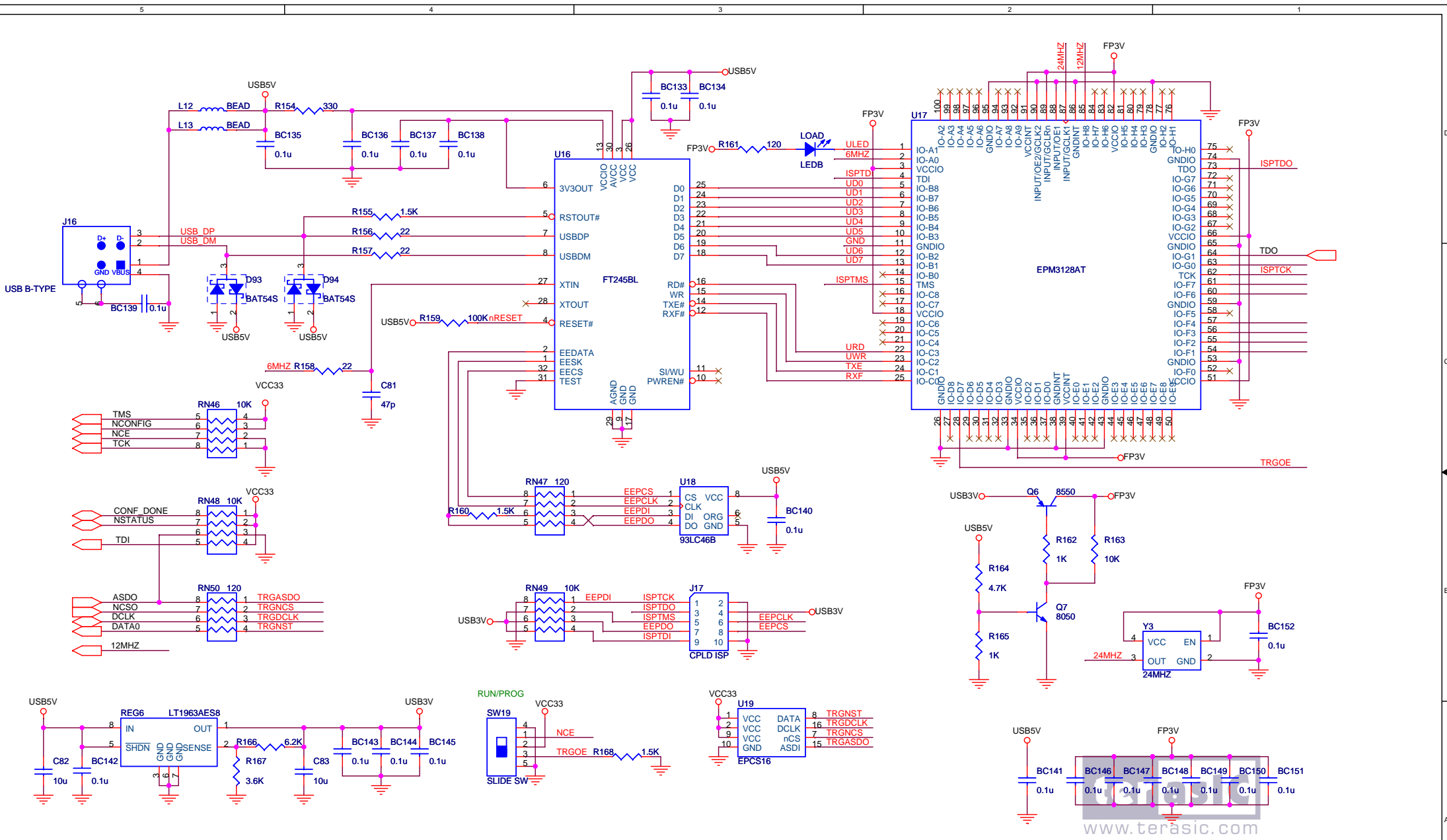

Copyright (c) 2007 by Terasic Technologies Inc. Taiwan.
 All rights reserved.
 No part of this schematic design may be reproduced, duplicated, or used without the prior written permission of Terasic.

Title		
ALTERA DE2-70		
Size	Document Number	Rev
B	USB BLASTER	1.0
Date:	Monday, November 26, 2007	Sheet 25 of 25