

if don't consider EMI and ESD ,The R11 don't add.otherwise they should be added .

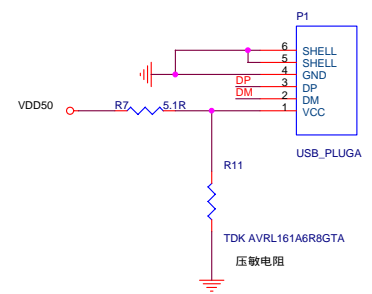

C8,C9 need Approaches the 13 Pin

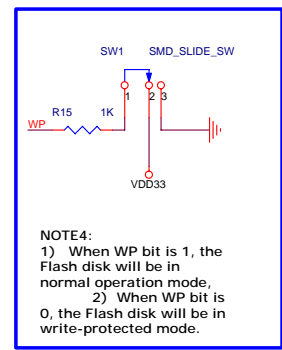
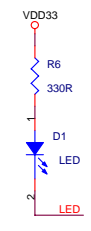
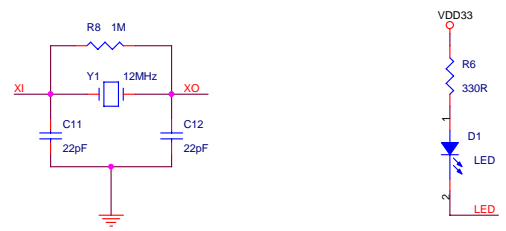
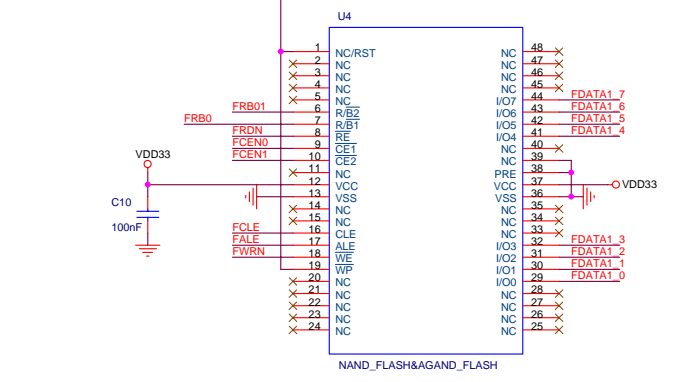

NOTE4:
 1) When WP bit is 1, the Flash disk will be in normal operation mode,
 2) When WP bit is 0, the Flash disk will be in write-protected mode.

Note:
 When Use only lpcs flash,Please SMT U1 location

Note:

IC Type	CBM2090&CBM2090E	CBM2091
Flash Type	R3 Should be Shorted	R3 Short,R4,R5,R9,R10,R12 Open
2CE Flash	R4,R5,R9,R10,R12 should be opened	
4CE Flash	R3,R4,R5 Should be Shorted	R3,R9,R12 Should be Shorted
Flash 6PIN is GND	R9,R10,R12 should be Opened R10 Should be Shorted, R3,R4,R5,R9,R12 should be opened	R4,R5,R10 should be Opened R10 Should be Shorted, R3,R4,R5,R9,R12 should be opened
others	Please view the Pin configuration of the Flash datasheet	

绘制:	stevan.luo	
设计:	stevan.luo	
版本:	V1.03	图纸尺寸: Custom
最近修改日期:	Wednesday, October 17, 2007	工程名: CBM2090_48 Generic solution
页码:	1 of 1	文本号: 20070206
芯邦文件控制等级:	Publicity	地址: 深圳市南山高新区科技中二路软件园4号楼二层201-205