

Design With PIN Diodes

APN1002

The PIN diode finds wide usage in RF, UHF and microwave circuits. It is fundamentally a device whose impedance, at these frequencies, is controlled by its DC excitation. A unique feature of the PIN diode is its ability to control large amounts of RF power with much lower levels of DC.

PIN Diode Fundamentals

The PIN diode is a current controlled resistor at radio and microwave frequencies. It is a silicon semiconductor diode in which a high resistivity intrinsic I region is sandwiched between a P-type and N-type region. When the PIN diode is forward biased, holes and electrons are injected into the I region. These charges do not immediately annihilate each other; instead they stay alive for an average time, called the carrier lifetime, τ . This results in an average stored charge, Q, which lowers the effective resistance of the I region to a value R_S .

When the PIN diode is at zero or reverse bias there is no stored charge in the I region and the diode appears as a capacitor, C_T , shunted by a parallel resistance R_P .

PIN diodes are specified for the following parameters:

- R_S series resistance under forward bias
- C_T total capacitance at zero or reverse bias
- R_D parallel resistance at zero or reverse bias
- V_R maximum allowable DC reverse bias voltage
- τ carrier lifetime
- θ_{AVE} average thermal resistance *or*
- P_D maximum average power dissipation
- θ_{pulse} pulse thermal impedance *or*
- P_P maximum peak power dissipation

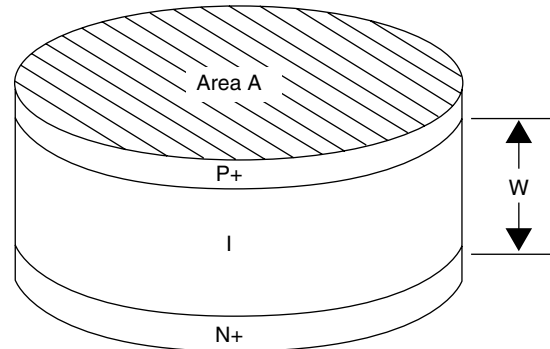

Figure 1

By varying the I region width and diode area it is possible to construct PIN diodes of different geometrics to result in the same R_S and C_T characteristic. These devices may have similar small signal characteristics. However, the thicker I region diode would have a higher bulk, or R_F breakdown voltage and better distortion properties. On the other hand, the thinner device would have faster switching speed.

There is a common misconception that carrier lifetime, τ , is the only parameter that determines the lowest frequency of operation and the distortion produced. This is indeed a factor, but equally important is the thickness of the I region, W, which relates to the transit time frequency of the PIN diode.

Low Frequency Model

At low frequencies (below the transit time frequency of the I region) and DC the PIN diode behaves like a silicon PN junction semiconductor diode. Its I-V characteristic determines the DC voltage at the forward bias current level. PIN diodes are often rated for the forward voltage, V_F , at a fixed DC bias.

The reverse voltage ratings on a PIN diode, V_R , are a guarantee from the manufacturer that no more than a specified amount, generally $10 \mu A$, of reverse current will flow when V_R is applied. It is not necessarily the avalanche or bulk breakdown voltage, V_B , which is determined by the I region width (approximately $10 V/\mu m$). PIN diodes of the same bulk breakdown voltage may have different voltage ratings. Generally, the lower the voltage rating the less expensive the PIN diode.

Large Signal Model

When the PIN diode is forward biased the stored charge, Q , must be much greater than the incremental stored charge added or removed by the RF current, I_{RF} . To insure this the following inequality must hold:

$$Q \gg \frac{I_{RF}}{2 \pi f}$$

RF Electrical Modeling of PIN Diode

Forward Bias Model

$$R_S = \frac{W^2}{(\mu_n + \mu_p) Q} \quad (\Omega)$$

Where:

- $Q = I_F \times \tau$ (coulombs)
- $W = I$ region width
- $I_F =$ forward bias current
- $\tau =$ carrier lifetime
- $\mu_n =$ electron mobility
- $\mu_p =$ hole mobility



Notes:

1. In practical diode the parasitic resistance of the diode package and contact limit the lowest resistance value.
2. The lowest impedance will be affected by the parasitic inductance, L , which is generally less than 1 nHy.
3. The equation is valid at frequencies higher than the I region transit time frequency, i.e.,

$$f > \frac{1300}{W^2} \quad (\text{where frequency is in MHz and } W \text{ in } \mu m).$$

4. The equation assumes that the RF signal does not affect the stored charge.

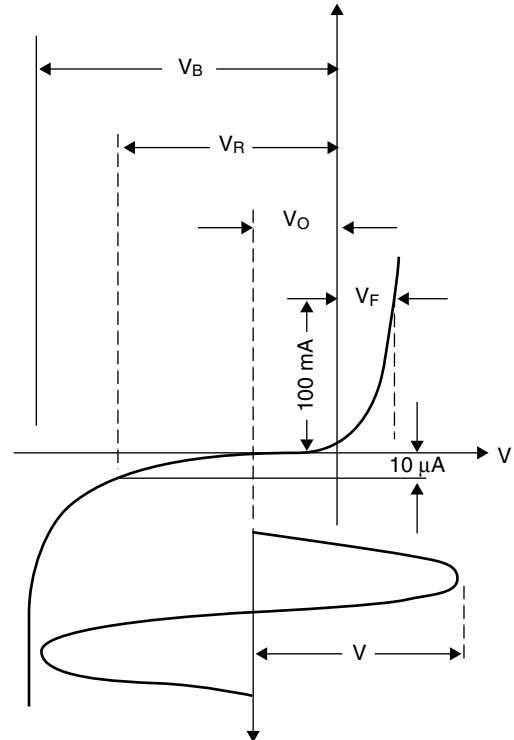

Figure 2

Zero or Reverse Bias Model

$$C_T = \frac{\epsilon A}{W}$$

Where:

- $\epsilon =$ dielectric constant of silicon
- $A =$ area of diode junction

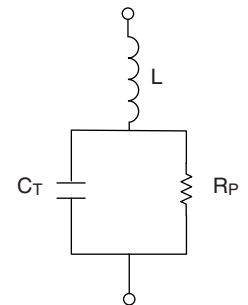

Notes:

1. The above equation is valid at frequencies above the dielectric relaxation frequency of the I region, i.e.

$$f > \frac{1}{2\pi \rho \epsilon} \quad (\text{where } \rho \text{ is the resistivity of the I region}).$$

At lower frequencies the PIN diode acts like a varactor.

2. The value R_P is proportional to voltage and inversely proportional to frequency. In most RF applications its value is higher than the reactance of the capacitance, C_T , and is less significant.

Under reverse bias the diode should not be biased beyond its DC voltage rating, V_R . The avalanche or bulk breakdown voltage, V_B , of a PIN diode is proportional to the I region wide, W , and is always higher than V_R . In a typical application maximum negative voltage swing should never exceed V_B . An instantaneous excursion of the RF signal into the positive bias direction generally does not cause the diode to go into conduction because of slow reverse to forward switching speed. The DC reverse bias needed to maintain low PIN diode conductance has been analyzed⁶ and is related to the magnitude of the RF signal and I region width.

Switching Speed Model

The switching speed in any application depends on the driver circuit, as well as the PIN diode. The primary PIN properties that influence switching speed may be explained as follows:

A PIN diode has two switching speeds from forward bias to reverse bias, T_{FR} , and from reverse bias to forward bias, T_{RF} . The diode characteristic that affects T_{FR} is τ , carrier lifetime. The value of T_{FR} may be computed from the forward current, I_F , and the initial reverse current I_R , as follows:

$$T_{FR} = \tau \log_e \left(1 + \frac{I_F}{I_R} \right) \quad (\text{Secs})$$

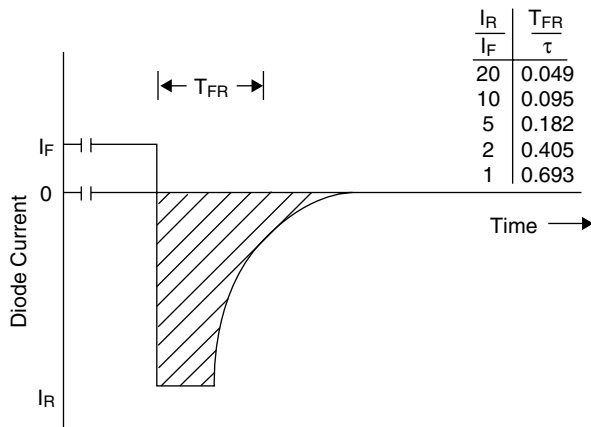

Figure 3

T_{RF} depends primarily on I region width, W , as indicated in the following chart which shows typical data:

I-Width μm	To 10 mA from		To 50 mA from		To 100 mA from	
	10 V	100 V	10 V	100 V	10 V	100 V
175	7.0 μs	5.0 μs	3.0 μs	2.5 μs	2.0 μs	1.5 μs
100	2.5 μs	2.0 μs	1.0 μs	0.8 μs	0.6 μs	0.6 μs
50	0.5 μs	0.4 μs	0.3 μs	0.2 μs	0.2 μs	0.1 μs

Thermal Model

The maximum allowable power dissipation, P_D , is determined by the following equation:

$$P_D = \frac{T_J - T_A}{\theta} \quad (W)$$

where T_J is the maximum allowable junction temperature (usually 175°C) and T_A is the ambient or heat sink temperature. Power dissipation may be computed as the product of the RF current squared multiplied by the diode resistance, R_S .

For CW applications the value of thermal resistance, θ , used is the average thermal resistance, θ_{AV} .

In most pulsed RF and microwave applications where the duty factor, DF, is less than 10 percent and the pulse width, T_P , is less than the thermal time constant of the diode, good approximation of the effective value of θ in the above equation may be computed as follows:

$$\theta = DF \times \theta_{AV} + \theta_{TP} \quad \text{°C/W}$$

Where θ_{TP} is the thermal impedance of the diode for the time interval corresponding to T_P .

The following diagram indicates how junction temperature is affected during a pulsed RF application.

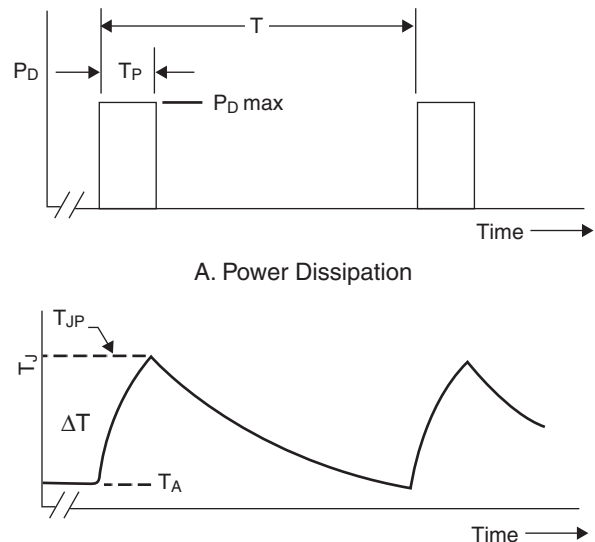

B. Junction Temperature

Figure 4

PIN Diode Applications

Switches

PIN diodes are commonly used as a switching element to control RF signals. In these applications, the PIN diode can be biased to either a high or low impedance device state, depending on the level of stored charge in the I region.

A simple untuned single-pole, single-throw (SPST) switch may be designed using either a single series or shunt connected PIN diode, as shown in Figure 5. The series connected diode switch is commonly used when minimum insertion loss is required over a broad frequency range. This design is also easier to physically realize using printed circuit techniques, since no through holes are required in the circuit board.

A single shunt mounted diode will, on the other hand, produce higher isolation values across a wider frequency range and will result in a design capable of handling more power since it is easier to heat sink the diode.

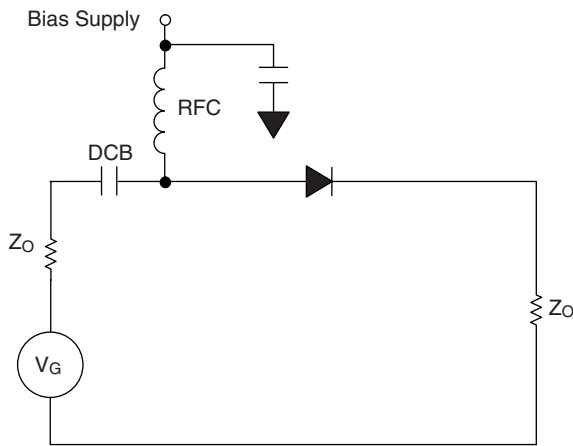

A. Series SPST Switch

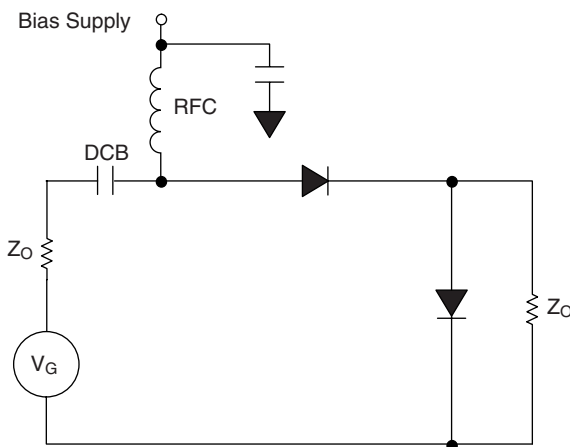

B. Shunt SPST Switch

Figure 5

Multi-throw switches are more frequently used than single-throw switches. A simple multi-throw switch may be designed employing a series PIN diode in each arm adjacent to the common port. Improved performance is obtained by using “compound switches,” which are combinations of series and shunt connected PIN diodes, in each arm.

For narrow-band applications, quarter-wave spaced multiple diodes may also be used in various switch designs. In the following section, we shall discuss each of these types of switches in detail and present design information for selecting PIN diodes and predicting circuit performance.

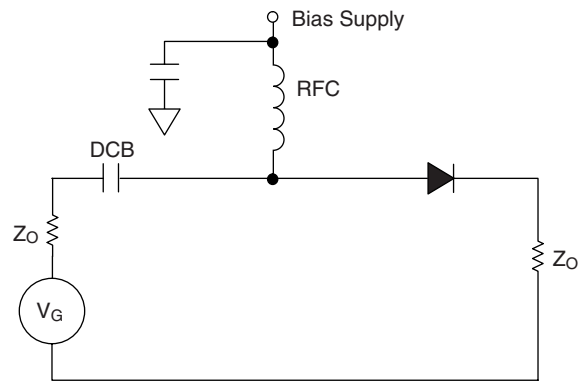

A. Single Pole Single Throw (SPST)

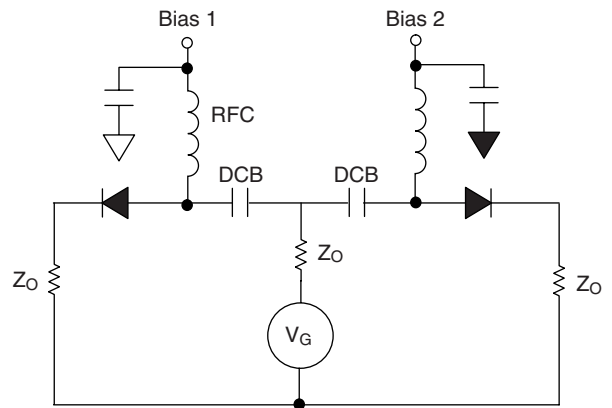

B. Single Pole Double Throw (SPST)

Figure 6

Series Connected Switch

Figure 6 shows two basic types of PIN diode series switches, (SPST and SPDT), commonly used in broadband designs. In both cases, the diode is in a “pass power” condition when it is forward biased and presents a low forward resistance, R_S , between the RF generator and load. For the “stop power” condition, the diode is at zero or reverse bias so that it presents a high impedance between the source and load. In series connected switches, the maximum isolation obtainable depends primarily on the capacitance of the PIN diode, while the insertion loss and power dissipation are functions of the diode resistance. The principal operating parameters of a series switch may be obtained using the following equations:

A. Insertion Loss (Series Switch)

$$IL = 20 \log_{10} \left[1 + \frac{R_S}{2Z_0} \right] \quad \text{dB} \quad (1)$$

This equation applies for an SPST switch and is graphically presented in Figure 7 for a 50 Ω impedance design. For multi-throw switches, the insertion loss is slightly higher due to any mismatch caused by the capacitance of the PIN diodes in the “off” arms. This additional insertion loss can be determined from Figure 10, after first computing the total shunt capacitance of all “off” arms of the multi-throw switch.

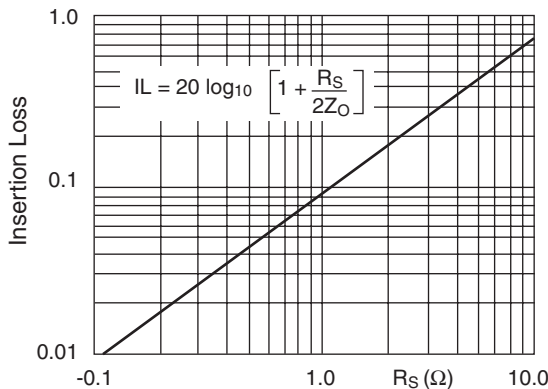

Figure 7. Insertion Loss for PIN Diode Series Switch in 50 Ω System

B. Isolation (Series Switch)

$$I = 10 \log_{10} \left[1 + (4\pi f C Z_0)^{-2} \right] \quad \text{dB} \quad (2)$$

This equation applies for an SPST diode switch. Add 6 dB for an SPNT switch to account for the 50 percent voltage reduction across the “off” diode, due to the termination of the generator in its characteristic impedance. Figure 8 graphically presents isolation as a function of capacitance for simple series switches. These curves are plotted for circuits terminated in 50 Ω loads.

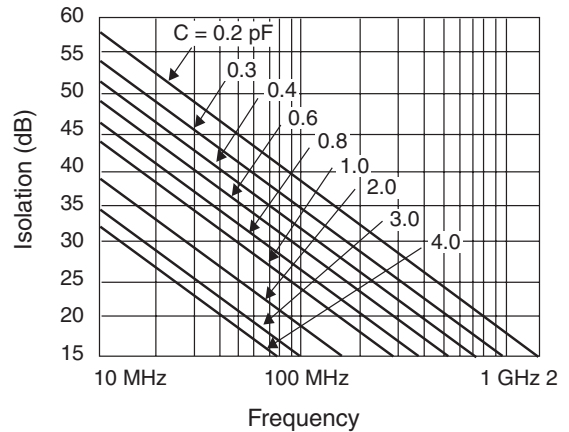

Figure 8. Isolation for SPST Diode Series Switch in 50 Ω System. Add 6 dB to Isolation for Multi-Throw Switches (SPNT)

C. Power Dissipation (Series Switch in Forward Bias)

$$P_D = \frac{4R_S Z_0}{(2Z_0 + R_S)^2} \cdot P_{AV} \quad [\text{W}] \quad (3)$$

For $Z_0 \gg R_S$, this becomes:

$$P_D \approx \frac{R_S}{Z_0} \cdot P_{AV} \quad [\text{W}] \quad (4)$$

Where the maximum available power is given by:

$$P_{AV} = \frac{V_G^2}{4Z_0} \quad [\text{W}] \quad (5)$$

It should be noted that Equations 3 and 4 apply only for perfectly matched switches. For SWR (σ) values other than unity, multiply these equations by $[2\sigma/(\sigma + 1)]^2$ to obtain the maximum required diode power dissipation rating.

D. Peak Current (Series Switch)

$$I_P = \sqrt{\frac{2P_{AV}}{Z_0}} \cdot \left(\frac{2\sigma}{\sigma + 1} \right) \quad [\text{amps}] \quad (6)$$

In the case of a 50 Ω system, this reduces to:

$$I_P = \sqrt{\frac{P_{AV}}{5}} \left(\frac{2\sigma}{\sigma + 1} \right) \quad [\text{amps}] \quad (7)$$

C. Peak RF Voltage (Series Switch)

$$V_P = \sqrt{8Z_O P_{AV}} \quad [\text{V}] \quad (\text{SPST})$$

$$V_P = \sqrt{2Z_O P_{AV}} \left(\frac{2\sigma}{\sigma + 1} \right) \quad [\text{V}] \quad (\text{SPST}) \quad (8)$$

For a 50 Ω system, this becomes:

$$V_P = 20 \sqrt{P_{AV}} \quad [\text{V}] \quad (\text{SPST})$$

$$V_P = 10 \sqrt{P_{AV}} \left(\frac{2\sigma}{\sigma + 1} \right) \quad [\text{V}] \quad (\text{SPST}) \quad (9)$$

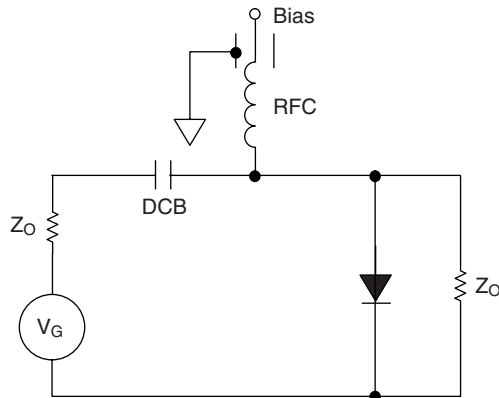

A. Single Pole Single Throw Switch (SPST)

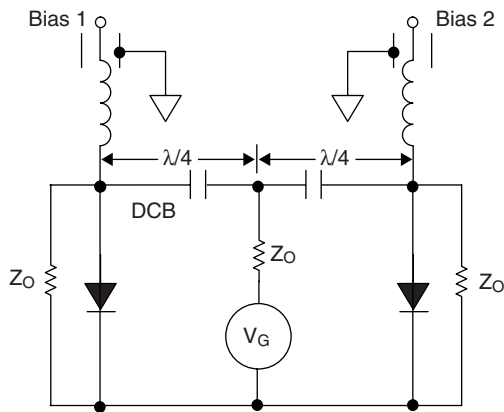

B. Single Pole Double Throw Switch (SPDT)

Figure 9. Shunt Connected Switches 2–5

Shunt Connected Switch

Figure 9 shows two typical shunt connected PIN diode switches. These shunt diode switches offer high isolation for many applications, and since the diode may be heat sunked at one electrode it is capable of handling more RF power than a diode in a series type switch.

In shunt switch designs, the isolation and power dissipation are functions of the diode’s forward resistance, whereas the insertion loss is primarily dependent on the capacitance of the PIN diode. The principal equations describing the operating parameters of shunt switches are given by:

A. Insertion Loss (Shunt Switch)

$$IL = 10 \log_{10} [1 + (\pi f C_T Z_O)^2] \quad [\text{dB}] \quad (10)$$

This equation applies for both SPST and SPNT shunt switches and is graphically presented in Figure 10 for a 50 Ω load impedance design.

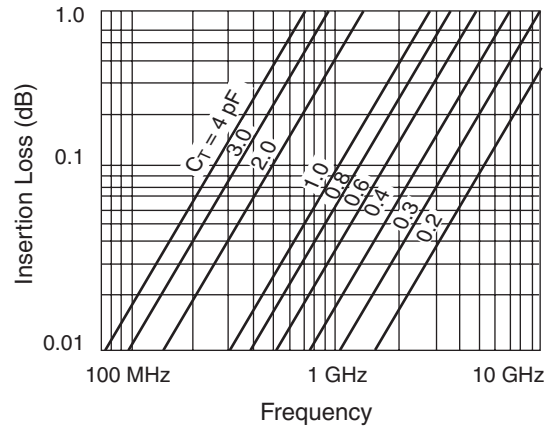

Figure 10. Insertion Loss for Shunt PIN Switch in 50 Ω System

B. Isolation (Shunt Switch)

$$I = 20 \log_{10} \left[1 + \frac{Z_O}{2R_S} \right] \quad [\text{dB}] \quad (11)$$

This equation, which is illustrated in Figure 11, applies for an SPST shunt switch. Add 6 dB to these values to obtain the correct isolation for a multi-throw switch.

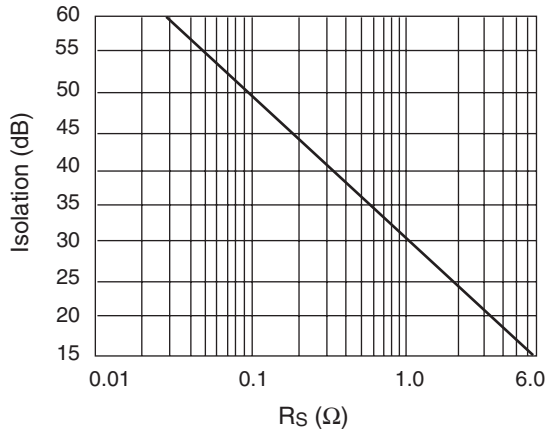

Figure 11. Isolation for SPST Shunt PIN Switches in 50 Ω System. Add 6 dB to Isolation for Multi-Throw Switches (SPNT)

C. Power Dissipation (Shunt Switch in Forward Bias)

$$P_D = \frac{4R_S Z_O}{(Z_O + 2R_S)^2} \cdot P_{AV} \quad [W] \quad (12)$$

For $Z_O \gg R_S$ this becomes:

$$P_D = \frac{4R_S}{Z_O} \cdot P_{AV} \quad [W] \quad (13)$$

where the maximum available power is given by:

$$P_{AV} = \frac{V_G^2}{4Z_O} \quad (14)$$

D. Power Dissipation (Shunt Switch in Reverse)

$$P_D = \frac{Z_O}{R_P} \cdot P_{AV} \quad [W] \quad (15)$$

where R_P is the reverse biased diode's parallel resistance.

E. Peak RF Current (Shunt Switch)

$$I_P = \sqrt{\frac{8P_{AV}}{Z_O}} \quad [\text{amps}] \quad (\text{SPST})$$

$$I_P = \sqrt{\frac{2P_{AV}}{Z_O} \left(\frac{2\sigma}{\sigma + 1} \right)} \quad [\text{amps}] \quad \text{SPNT} \quad (16)$$

for a 50 Ω system, this becomes:

$$I_P = 0.4 \sqrt{P_{AV}} \quad [\text{amps}] \quad (\text{SPST})$$

$$I_P = 0.2 \sqrt{P_{AV} \left(\frac{2\sigma}{\sigma + 1} \right)} \quad [\text{amps}] \quad \text{SPNT} \quad (17)$$

F. Peak RF Voltage (Shunt Switch)

$$V_P = \sqrt{2Z_O P_{AV}} \left(\frac{2\sigma}{\sigma + 1} \right) \quad [V] \quad (18)$$

In the case of a 50 Ω system, this reduces to:

$$V_P = 10 \sqrt{P_{AV}} \left(\frac{2\sigma}{\sigma + 1} \right) \quad [V] \quad (19)$$

Compound and Tuned Switches

In practice, it is usually difficult to achieve more than 40 dB isolation using a single PIN diode, either in shunt or series, at RF and higher frequencies. The causes of this limitation are generally radiation effects in the transmission medium and inadequate shielding. To overcome this there are switch designs that employ combinations of series and shunt diodes (compound switches), and switches that employ resonant structures (tuned switches) affecting improved isolation performance.

The two most common compound switch configurations are PIN diodes mounted in either ELL (series-shunt) or TEE designs, as shown in Figure 12. In the insertion loss state for a compound switch the series diode is forward biased and the shunt diode is at zero or reverse bias. The reverse is true for the isolation state. This adds some complexity to the bias circuitry in comparison to simple switches. A summary of formulas used for calculating insertion loss and isolation for compound and simple switches is given in Figure 13.

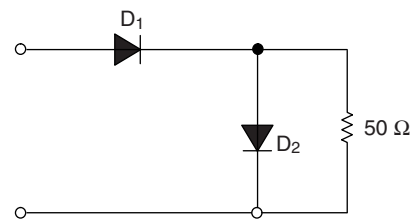

A. ELL (Series-Shunt) SPST Switch

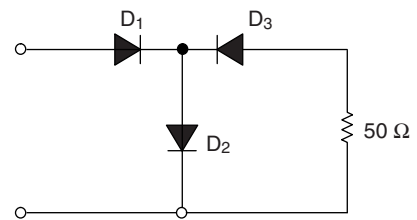

B. TEE SPST Switch

Figure 12. Compound Switches

Type	Isolation	Insertion Loss (dB)
Series	$10 \log_{10} \left[1 + \left(\frac{X_C}{2Z_0} \right)^2 \right]$	$20 \log_{10} \left[1 + \frac{R_S}{2Z_0} \right]$
Shunt	$20 \log_{10} \left[1 + \frac{Z_0}{2R_S} \right]$	$10 \log_{10} \left[1 + \left(\frac{Z_0}{2X_C} \right)^2 \right]$
Series-Shunt	$10 \log_{10} \left[\left(1 + \frac{Z_0}{2R_S} \right)^2 + \left(\frac{X_C}{2Z_0} \right)^2 \left(1 + \frac{Z_0}{R_S} \right)^2 \right]$	$10 \log_{10} \left[\left(1 + \frac{R_S}{2Z_0} \right)^2 + \left(\frac{Z_0 + R_S}{2X_C} \right)^2 \right]$
TEE	$10 \log_{10} \left[1 + \left(\frac{X_C}{Z_0} \right)^2 \right] + 10 \log_{10} \left[\left(1 + \frac{Z_0}{2R_S} \right)^2 + \left(\frac{X_C}{2R_S} \right)^2 \right]$	$20 \log_{10} \left[1 + \frac{R_S}{Z_0} \right] + 10 \log_{10} \left[1 + \left(\frac{Z_0 + R_S}{2X_C} \right)^2 \right]$

Figure 13. Summary of Formulas for SPST Switches.
 (Add 6 dB to Isolation to Obtain Value for Single-Pole Multiple Throw Switch.)

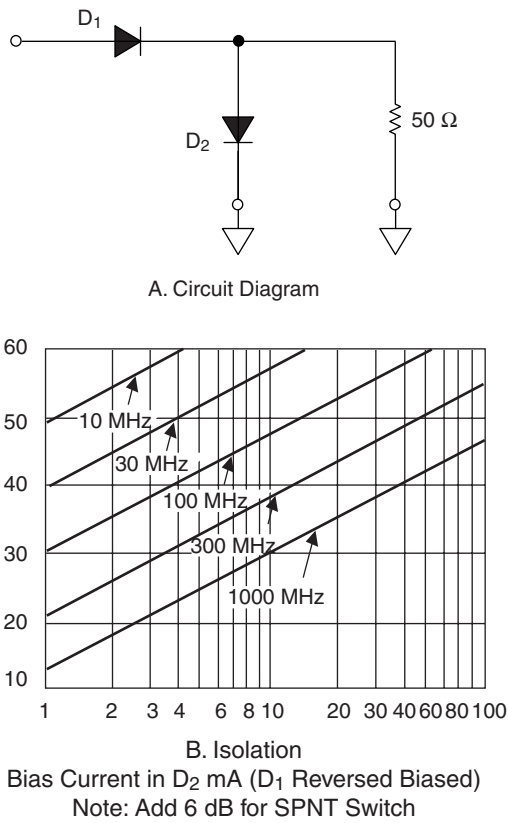

Figure 14. Series Shunt Switch

Figure 14 shows the performance of an ELL type switch a diode rated at 3.3 pF, maximum capacitance, and 0.25 Ω, R_S maximum at 100 mA. In comparison, a simple series connected using the same diode switch would have similar insertion loss to the 100 MHz contour and the isolation would be 15 dB maximum at 100 MHz, falling off at the rate of 6 dB per octave.

A tuned switch may be constructed by spacing two series diodes or two shunt diodes a wavelength apart, as shown in Figure 15. The resulting value of isolation in the tuned switch is twice that obtainable in a single diode switch. The insertion loss of the tuned series switch is higher than that of the simple series switch and may be computed using

the sum of the diode resistance as the R_S value in equation 1. In the tuned shunt switch the insertion loss may even be lower than in a simple shunt switch because of a resonant effect of the spaced diode capacitances.

Quarter-wave spacing need not be limited to frequencies where the wavelength is short enough to install a discrete length of line. There is a lumped circuit equivalent which simulates the quarter-wave section and may be used in RF band. This is shown in Figure 16. These tuned circuit techniques are effective in applications having bandwidths on the order of 10 percent of the center frequency.

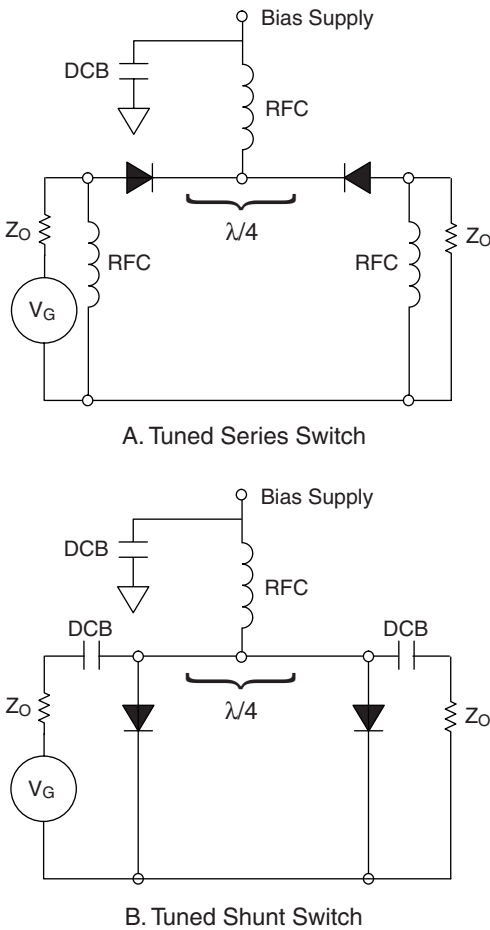
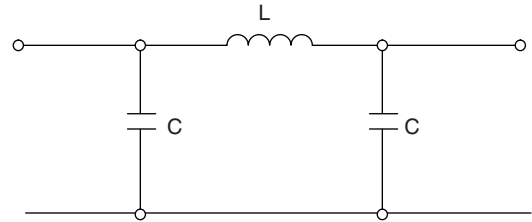

Figure 15

Transmit-Receive Switches

There is a class of switches used in transceiver applications whose function is to connect the antenna to the transmitter (exciter) in the transmit state and to the receiver during the receiver state. When PIN diodes are used as elements in these switches they offer higher reliability, better mechanical ruggedness and faster switching speed than electro-mechanical designs.



$$L = \frac{Z_0}{2\pi f} \quad (\text{henries})$$

$$L = \frac{1}{2\pi f_0 Z_0} \quad (\text{farads})$$

Figure 16. Quarter-Wave Line Equivalent

The basic circuit for an electronic switch consists of a PIN diode connected in series with the transmitter, and a shunt diode connected a quarter wavelength ($\lambda/4$ section Figure 16) and, of course, are preferable for transceivers that operate at long wavelengths.

When switched into the transmit state each diode becomes forward biased. The series diode appears as a low impedance to the signal heading toward the antenna and the shunt diode effectively shorts the receiver's antenna terminals to prevent overloading. Transmitter insertion loss and receiver isolation depend on the diode resistance. If R_S is 1 Ω greater than 30 dB isolation and less than 0.2 dB insertion, loss can be expected. This performance is achievable over a 10 percent bandwidth.

In the receive condition the diodes are at zero or reverse bias and present essentially a low capacitance, C_T , which creates a direct low insertion loss path between the antenna and receiver. The off transmitter is isolated from this path by the high impedance series diode.

The amount of power, P_A , this switch can handle depends on the power rating of the PIN diode, P_D , and the diode resistance. The equation showing this relationship is as follows for an antenna maximum SWR of σ :

$$P_A = \frac{P_D Z_0}{R_S} \left(\frac{\sigma + 1}{2\sigma} \right)^2 \quad [W]$$

In a 50 Ω system where the condition of a totally mismatched antenna must be considered this equation reduces to:

$$P_A = \frac{12.5 \times P_D}{R_S} \quad [W]$$

The SMP1322-011 is a surface mount PIN diode rated at 0.25 W dissipation to a 25°C contact. The resistance of this diode is a 0.50 Ω (max) at 10 mA. A quarter-wave switch using SMP1322-011 may then be computed to handle 6.25 W with a totally mismatched antenna.

It should be pointed out that the shunt diode of the quarter-wave antenna switch dissipates about as much power as the series diode. This may not be apparent from Figure 17; however, it may be shown that the RF current in both the series and shunt diode is practically identical.

Broadband antenna switches using PIN diodes may be designed using the series connected diode circuit shown in Figure 18. The frequency limitation of this switch results primarily from the capacitance of D₂.

In this case forward bias is applied either to D₁ during the transmit of D₂ during receive. In high power application (> 5 W) it is often necessary to apply reverse voltage on D₂ during transmit. This may be accomplished either by

a negative polarity power supply at Bias 2, or by having the forward bias current of D₁ flow through resistor R to apply the required negative voltage.

The selection of diode D₁ is based primarily on its power handling capability. It need not have a high voltage rating since it is always forward biased in its low resistance state when high RF power is applied. Diode D₂ does not pass high RF current but must be able to hold off the RF voltage generated by the transmitter. It is primarily selected on the basis of its capacitance, which determines the upper frequency limit and its ability to operate at low distortion.

Using the SMP1322-011 as D₁, and a SMP1302-001 or SOT-23 PIN diode which are rated at 0.3 pF max as D₂, greater than 25 dB receiver isolation may be achieved up to 400 MHz. The expected transmit and receive insertion loss with the PIN diodes biased at 10 mA are 0.1 dB and 0.3 dB, respectively. This switch can handle RF power levels up to 6.25 W.

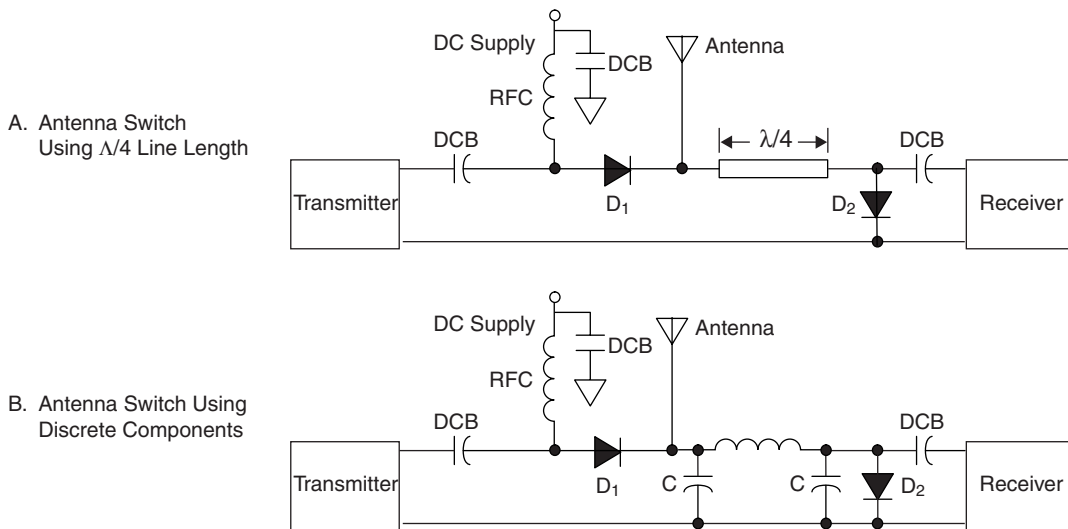

Figure 17. Quarter-Wave Antenna Switches

Practical Design Hints

PIN diode circuit performance at RF frequencies is predictable and should conform closely to the design equations. When a switch is not performing satisfactorily, the fault is often not due to the PIN diode but to other circuit limitations, such as circuit loss, bias circuit interaction or lead length problems (primarily when shunt PIN diodes are employed).

It is good practice in a new design to first evaluate the circuit loss by substituting alternatively a wire short or open in place of the PIN diode. This will simulate the circuit performance with “ideal PIN diodes.” Any deficiency in the external circuit may then be corrected before inserting the PIN diodes.

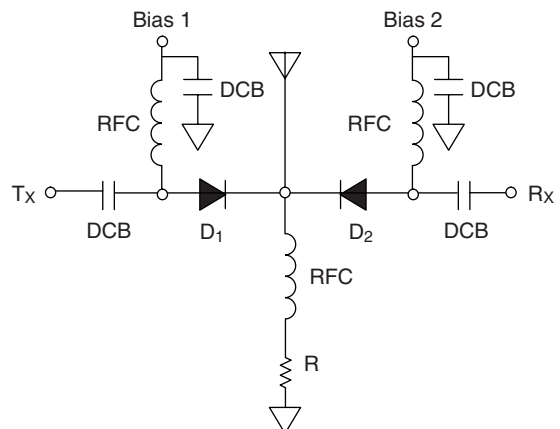

Figure 18. Broadband Antenna Switch

PIN Diode Attenuators

In an attenuator application the resistance characteristic of the PIN diode is exploited not only at its extreme high and low values, as in switches, but at the finite values in between.

The resistance characteristic of a PIN diode when forward biased to IF1 depends on the I region width (W) carrier lifetime (τ), and the hole and electron mobilities μ_p μ_n as follows:

$$R_S = W^2 / (\mu_p + \mu_n) I_F \tau \quad \Omega \quad (1)$$

For a PIN diode with an I region width of typically 250 μm , carrier lifetime of 4 μs , and μ_n of 0.13, μ_p of 0.05 $\text{m}^2/\text{v}\cdot\text{s}$, Figure 19 shows the R_S versus current characteristic.

In the selection of a PIN diode for an attenuator application the designer must often be concerned about the range of diode resistance, which will define the dynamic range of the attenuator. PIN diode attenuators tend to be more distortion sensitive than switches since their operating bias point often occurs at a low value of quiescent stored charge. A thin I region PIN will operate at lower forward bias currents than thick PIN diodes, but the thicker one will generate less distortion.

PIN diode attenuator circuits are used extensively in Automatic Gain Control (AGC) and RF leveling applications, as well as in electronically controlled attenuators and modulators. A typical configuration of an AGC application is shown in Figure 20. The PIN diode attenuator may take many forms ranging from a simple series or shunt mounted diode acting as a lossy reflective switch, or a more complex structure that maintains a constant matched input impedance across the full dynamic range of the attenuator.

Although there are other methods for providing AGC functions, such as varying the gain of the RF transistor amplifier, the PIN diode approach generally results in lower power drain, less frequency pulling, and lower RF signal distortion. The latter results are especially true when diodes with thick I regions and long carrier lifetimes are used in the attenuator circuits. Using these PIN diodes one can achieve wide dynamic range attenuation with low signal distortion at frequencies ranging from below 1 MHz up to well over 1 GHz.

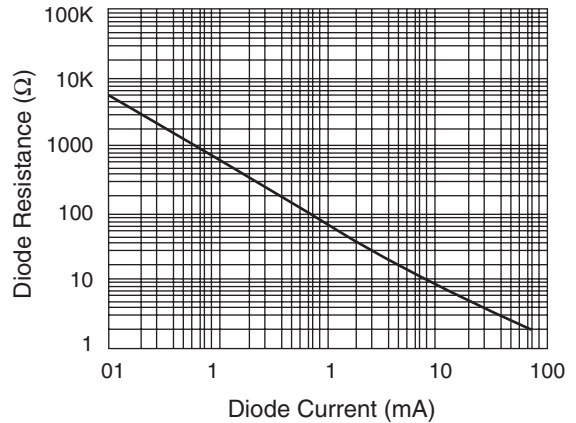

Figure 19. Typical Diode Resistance vs. Forward Current

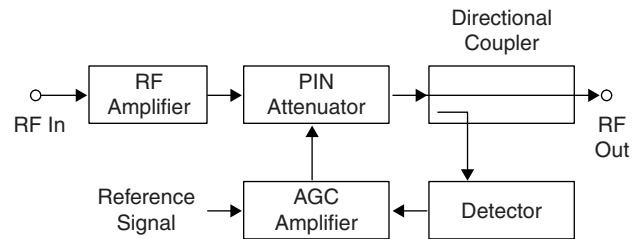

Figure 20. RF AGC/Leveler Circuit

Reflective Attenuators

An attenuator may be designed using single series or shunt connected PIN diode switch configurations, as shown in Figure 21. These attenuator circuits utilize the current controlled resistance characteristic of the PIN diode, not only in its low loss states (very high or low resistance), but also at in-between, finite resistance values.

The attenuation value obtained using these circuits may be computed from the following equations:

Attenuation of Series Connected PIN Diode Attenuator

$$A = 20 \log \left(1 + \frac{R_S}{2Z_O} \right) \quad \text{dB} \quad (2)$$

Attenuation of Shunt Connected PIN Diode Attenuator

$$A = 20 \log \left(1 + \frac{Z_O}{2R_S} \right) \quad \text{dB} \quad (3)$$

These equations assume the PIN diode to be purely resistive. The reactance of the PIN diode capacitance, however, must also be taken into account at frequencies where its value begins to approach the PIN diode resistance value.

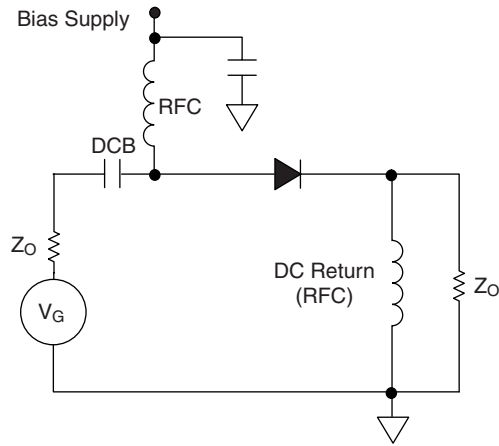

A. Series SPST Switch

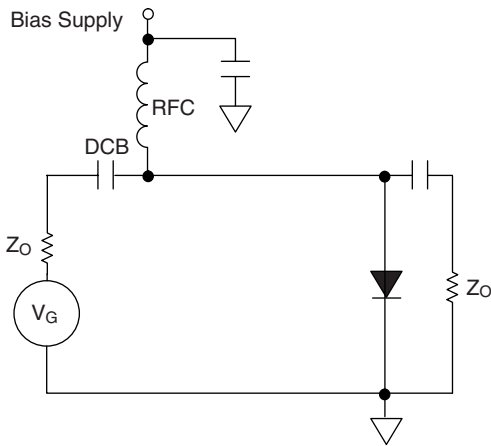

B. Shunt SPST Switch

Figure 21. SPST PIN Diode Switches

Matched Attenuators

Attenuators built from switch design are basically reflective devices which attenuate the signal by producing a mismatch between the source and the load. Matched PIN diode attenuator designs, which exhibit constant input impedance across the entire attenuation range, are also available which use either multiple PIN diodes biased at different resistance points or bandwidth limited circuits utilizing tuned elements. They are described as follows:

Quadrature Hybrid Attenuators

Although a matched PIN attenuator may be achieved by combining a ferrite circulator with one of the previous simple reflective devices, the more common approach makes use of quadrature hybrid circuits. Quadrature hybrids are commonly available at frequencies from below 10 MHz to above 1 GHz, with bandwidth coverage often exceeding a decade. Figures 22 and 23 show typical

quadrature hybrid circuits employing series and shunt connected PIN diodes. The following equations summarize this performance:

Quadrature Hybrid
(Series Connected PIN Diodes)

$$A = 20 \log \left(1 + \frac{2Z_0}{R_S} \right) \text{ dB (4)}$$

Quadrature Hybrid
(Shunt Connected PIN Diodes)

$$A = 20 \log \left(1 + \frac{2R_S}{Z_0} \right) \text{ dB (5)}$$

The quadrature hybrid design approach is superior to the circulator coupled attenuator from the standpoint of lower cost and the achievement of lower frequency operation. Because the incident power is divided into two paths, the quadrature hybrid configuration is also capable of handling twice the power, and this occurs at the 6 dB attenuation point. Each load resistor, however, must be capable of dissipating one half the total input power at the time of maximum attenuation.

Both the above types of hybrid attenuators offer good dynamic range. The series connected diode configuration is, however, recommended for attenuators used primarily at high attenuation levels (greater than 6 dB), while the shunt mounted diode configuration is better suited for low attenuation ranges.

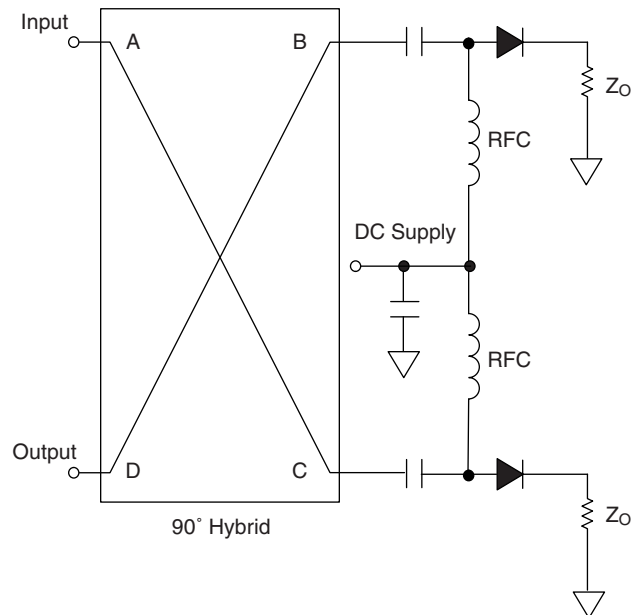

Figure 22. Quadrature Matched Hybrid Attenuator (Series Connected Diodes)

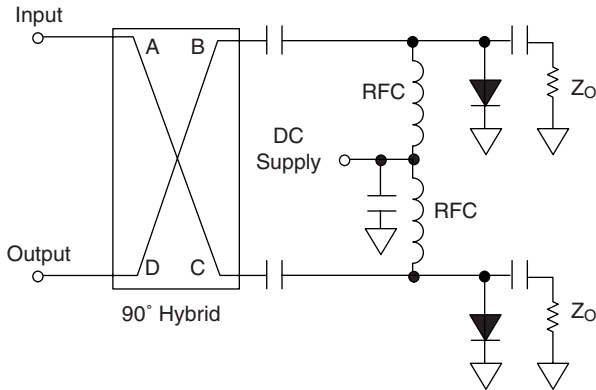

Figure 23. Quadrature Hybrid Matched Attenuator (Shunt Connected PIN Diodes)

Constant impedance attenuator circuit. The power incident on port A divides equally between ports B and C, port D is isolated. The mismatch produced by the PIN diode resistance in parallel with the load resistance at ports B and C reflects part of the power. The reflected power exits port D, isolating port A. Therefore, A appears matched to the input signal.

Quadrature hybrid attenuators may also be constructed without the load resistor attached in series or parallel to the PIN diode as shown. In these circuits the forward current is increased from the 50 Ω, maximum attenuation/ R_S value to lower resistance values. This results in increased stored charge as the attenuation is lowered, which is desirable for lower distortion. The purpose of the load resistor is both to make the attenuator less sensitive to individual diode differences and to increase the power handling capacity by a factor of two.

Quarter-Wave Attenuators

An attenuator matched at the input may also be built using quarter-wave techniques. Figures 24 and 25 show examples of these circuits. For the quarter-wave section a lumped equivalent may be employed at frequencies too low for practical use of line lengths. This equivalent is shown in Figure 26.

The performance equations for these circuits are given below:

Quarter-Wave Attenuator
(Series Connected Diode)

$$A = 20 \log \left(1 + \frac{Z_0}{R_S} \right) \quad \text{dB (6)}$$

$$A = 20 \log \left(1 + \frac{R_S}{Z_0} \right) \quad \text{dB (7)}$$

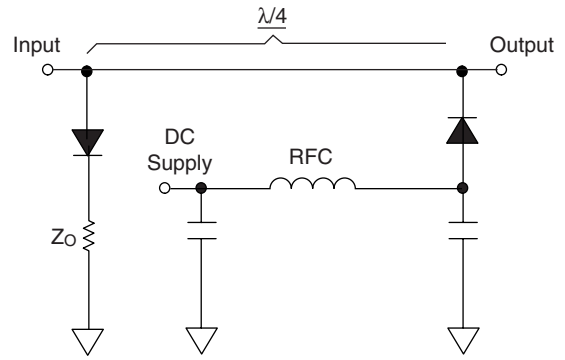

Figure 24. Quarter-Wave Matched Attenuator (Series Connected Diodes)

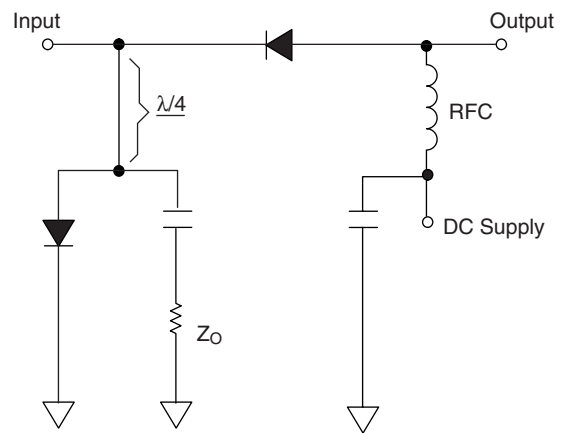

Figure 25. Quarter-Wave Matched Attenuator (Shunt Connected Diodes)

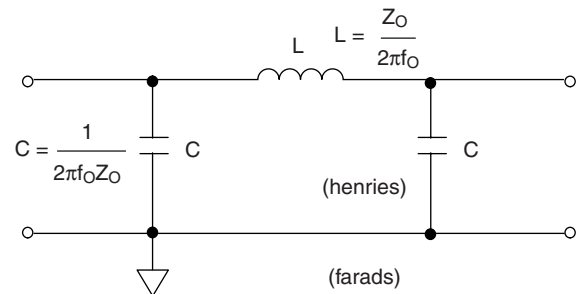

Figure 26. Lumped Circuit Equivalent of Quarter-Wave Line

A matched condition is achieved in these circuits when both diodes are at the same resistance. This condition should normally occur when using similar diodes, since they are DC series connected, with the same forward bias current flowing through each diode. The series circuit of Figure 24 is recommended for use at high attenuation levels, while the shunt diode circuit of Figure 25 is better suited for low attenuation circuits.

Bridged TEE and PI Attenuators

For matched broadband applications, especially those covering the low R_D (1 MHz) through UHF, attenuator designs using multiple PIN diodes are employed. Commonly used for this application are the bridged TEE and PI circuits shown in Figures 27 and 28.

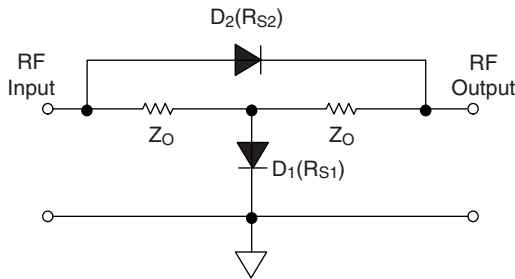

Figure 27. Bridged TEE Attenuator

The attenuation obtained using a bridged TEE circuit may be calculated from the following:

$$A = 20 \log \left(1 + \frac{Z_0}{R_{S1}} \right) \text{ dB} \quad (8)$$

Where:

$$Z_0^2 = R_{S1} \times R_{S2} \quad \Omega^2 \quad (9)$$

The relationship between the forward resistance of the two diodes insures maintenance of a matched circuit at all attenuation values.

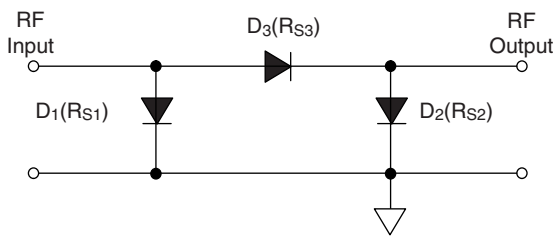

Figure 28. PI Attenuator (The π and TEE are Broadband Matched Attenuator Circuits)

The expressions for attenuation and matching conditions for the PI attenuator are given as follows:

$$A = 20 \log \left(\frac{R_{S1} + Z_0}{R_{S1} - Z_0} \right) \text{ dB} \quad (10)$$

Where:

$$R_{S3} = \frac{2R_{S1}Z_0^2}{R_{S1}^2 - Z_0^2} \quad \Omega \quad (11)$$

$$R_{S1} = R_{S2} \quad \Omega \quad (12)$$

Using these expressions, Figure 29 gives a graphical display of diode resistance values for a 50 Ω PI attenuator. Note that the minimum value for R_{S1} and R_S is 50 Ω . In both the bridged TEE and PI attenuators, the PIN diodes are biased at two different resistance points simultaneously, which must track in order to achieve proper attenuator performance.

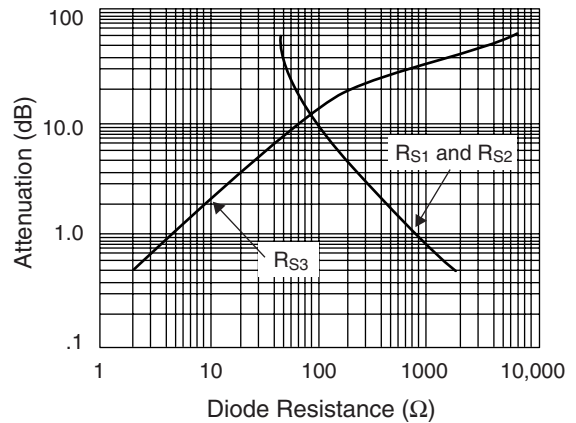

Figure 29. Attenuation of PI Attenuators

PIN Diode Modulators

PIN diode switches and attenuators may be used as RF amplitude modulators. Square wave or pulse modulation use PIN diode switch designs, whereas linear modulators use attenuator designs.

The design of high power or distortion sensitive modulator applications follow the same guidelines as their switch and attenuator counterparts. The PIN diodes they employ should have thick I regions. Series connected, or preferably back-to-back configurations always reduce distortion. The sacrifice in using these devices will be lower maximum frequencies and higher modulation current requirements.

The quadrature hybrid design is recommended as a building block for PIN diode modulators. Its inherent built-in isolation minimizes pulling and undesired phase modulation on the driving source.

PIN Diode Phase Shifters

PIN diodes are utilized as series or shunt connected switches in phase shifter circuit designs. In such cases, the elements switched are either lengths of transmission line or reactive elements. The criteria for choosing PIN diodes for use in phase shifters is similar to those used in selecting diodes for other switching applications. One additional factor, however, that must often be considered is the possibility of introducing phase distortion, particularly at high RF power levels or low reverse bias voltages. Of significant note is the fact that the properties inherent in PIN diodes which yield low distortion, i.e., a long carrier lifetime and thick I regions, also result in low phase distortion of the RF signal. Three of the most common types of semiconductor phase shifter circuits, namely the switched line, loaded line and hybrid coupled designs, are described as follows:

A. Switched Line Phase Shifter

A basic example of a switched line phase shifter circuit is shown in Figure 30. In this design, two SPDT switches employing PIN diodes are used to change the electrical length of transmission line by some length $\Delta \ell$. The phase shift obtained from this circuit varies with frequency and is a direct function of this differential line length as shown below:

$$\Delta\theta = 2\pi\Delta\ell/\lambda \quad \text{radians (13)}$$

The switched line phase shifter is inherently a broadband circuit producing true time delay, with the actual phase shift dependent only on $\Delta \ell$. Because of PIN diode capacitance limitations this design is most frequently used at frequencies below 1 GHz.

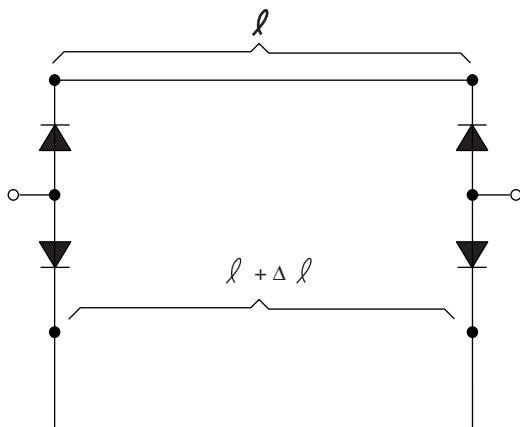

Figure 30. Switched Line Phase Shifter

The power capabilities and loss characteristics of the switched line phase shifter are the same as those of a series connected SPDT switch. A unique characteristic of

this circuit is that the power and voltage stress on each diode is independent of the amount of differential phase shift produced by each phase shifter. Thus, four diodes are required for each bit, with all diodes having the same power and voltage ratings.

B. Loaded Line Phase Shifter

The loaded line shifter design shown in Figure 31 operates on a different principle than the switched line phase shifter. In this design the desired maximum phase skirt is divided into several smaller phase shift sections, each containing a pair of PIN diodes, which do not completely perturbate the main transmission line. A major advantage of this phase shifter is its extremely high power capability, due partly to the use of shunt mounted diodes, plus the PIN diodes are never in the direct path of the full RF power.

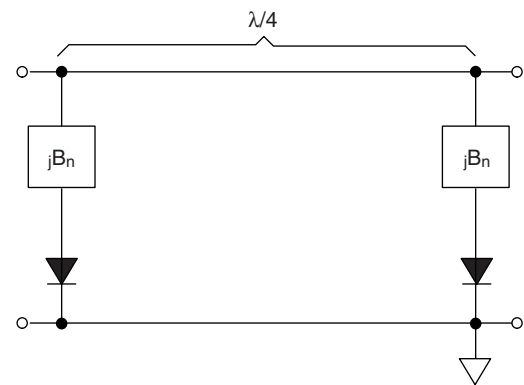

Figure 31. Loaded Line Phase Shifter

In loaded line phase shifters a normalized susceptance, B_n , is switched in and out of the transmission path by the PIN diodes. Typical circuits use values of B_n much less than unity, resulting in considerable decoupling of the transmitted RF power from the PIN diode. The phase shift for a single section is given as follows:

$$\theta = 2 \tan^{-1} \left(\frac{B_n}{1 - B_n^2/8} \right) \quad \text{radians (14)}$$

The maximum phase shift obtainable from a loaded line section is limited by both bandwidth and diode power handling considerations. The power constraint on obtainable phase shift is shown as follows:

$$\theta \text{ max} = 2 \tan^{-1} \left(\frac{V_{BR} I_F}{4P_L} \right) \quad \text{radians (15)}$$

Where:

- $\theta \text{ max}$ = maximum phase angle
- P_L = power transmitted
- V_{BR} = diode breakdown voltage
- I_F = diode current rating

The above factors limit the maximum phase shift angle in practical circuits to about 45°. Thus, a 180° phase shift would require the use of four 45° phase shift sections in its design.

Reflective Phase Shifter

A circuit design which handles both high RF power and large incremental phase shifts with the fewest number of diodes is the hybrid coupled phase shifter shown in Figure 32. The phase shift for this circuit is given below:

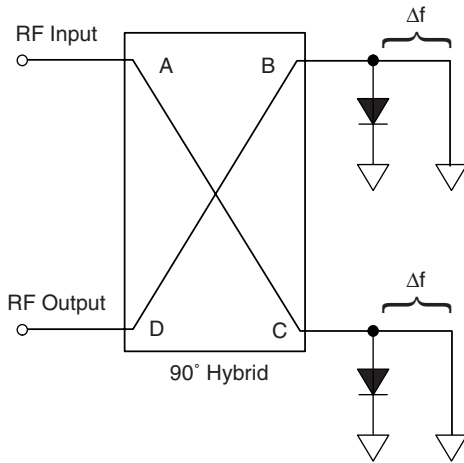

Figure 32. Hybrid Coupler Reflective Phase Shifter

The voltage stress on the shunt PIN diode in this circuit also depends on the amount of desired phase shift, or “bit” size. The greatest voltage stress is associated with the 180° bit and is reduced by the factor $(\sin\theta/2)^{1/2}$ for other bit sizes. The relationship between maximum phase shift, transmitted power, and PIN diode ratings is as follows:

$$\theta_{\max} = 2\sin^{-1} \left(\frac{V_{BR} I_F}{8P_L} \right) \quad \text{radians} \quad (17)$$

In comparison to the loaded line phase shifter, the hybrid design can handle up to twice the peak power when using the same diodes. In both hybrid and loaded line designs, the power dependency of the maximum bit size relates to the product of the maximum RF current and peak RF voltage the PIN diodes can handle. By judicious choice of the nominal impedance in the plane of the PIN diode, the current and voltage stress can usually be adjusted to be within the device ratings. In general, this implies lowering the nominal impedance to reduce the voltage

stress in favor of higher RF currents. For PIN diodes the maximum current rating should be specified or is dependent upon the diode power dissipation rating, while the maximum voltage stress at RF frequencies is dependent on I region thickness.

PIN Diode Distortion Model

The beginning sections of this article were concerned with large signal operation and thermal considerations allowing the circuit designer to avoid conditions that would lead to significant changes in PIN diode performance or excessive power dissipation. A subtle, but often significant operating characteristic is the distortion or change in signal shape, which is always produced by a PIN diode in the signal it controls.

The primary cause of distortion is any variation or non-linearity of the PIN diode impedance during the period of the applied RF signal. These variations could be in the diode’s forward bias resistance, R_S , parallel resistance, R_P , capacitance, C_T , or the effect of the low frequency I-V characteristic. The level of distortion can range from better than 100 dB below, to levels approaching the desired signal. The distortion could be analyzed in a fourier series and takes the traditional form of harmonic distortion of all orders, when applied to a single input signal, and harmonic intermodulation distortion when applied to multiple input signals.

Non-linear, distortion generating behavior is often desired in PIN and other RF oriented semiconductor diodes. Self-biasing limiter diodes are often designed as thin I region PIN diodes operating near or below their transit time frequency. In a detector or mixer diode the distortion that results from the ability of the diode to follow its I-V characteristic at high frequencies is exploited. In this regard, the term “square law detector” applied to a detector diode implies a second order distortion generator. In the PIN switch circuits discussed at the beginning of this article, and the attenuator and other applications discussed here, methods of selecting and operating PIN diodes to obtain low distortion are described.

There is a common misconception that minority carrier lifetime is the only significant PIN diode parameter that affects distortion. This is indeed a major factor but another important parameter is the width of the I region, which determines the transit time of the PIN diode. A diode with a long transit time will have more of a tendency to retain its quiescent level of stored charge. The longer transit time of a thick PIN diode reflects its ability to follow the stored charge model for PIN diode resistance according to:

$$Q = I_F \tau \quad \text{coulombs (18)}$$

$$R_S = \frac{W^2}{(\mu_p + \mu_n)Q} \quad \Omega \quad (19)$$

Where:

- I_F = forward bias current
- τ = carrier lifetime
- W = I region width
- μ_n = electron mobility
- μ_p = hole mobility

The effect of carrier lifetime on distortion relates to the quiescent level of stored charge induced by the DC forward bias current and the ratio of this stored charge to the incremental stored charge added or removed by the RF signal.

The distortion generated by a forward biased PIN diode switch has been analyzed and has been shown to be related to the ratio of stored charge to diode resistance and the operating frequency. Prediction equations for the second order intermodulation intercept point (IP2) and the third order intermodulation intercept point (IP3) have been developed from PIN semiconductor analysis and are presented as follows:

$$IP2 = 34 + 20 \log \frac{FQ}{R_S} \quad \text{dBm (20)}$$

$$IP3 = 21 + 15 \log \frac{FQ}{R_S} \quad \text{dBm (21)}$$

Where:

- F = Frequency in MHz
- R_S = PIN diode resistance in Ω
- Q = Stored charge in nC

In most applications, the distortion generated by a reversed biased diode is smaller than forward biased generated distortion for small or moderate signal size. This is particularly the case when the reverse bias applied to the PIN diode is larger than the peak RF voltage, preventing any instantaneous swing into the forward bias direction.

Distortion produced in a PIN diode circuit may be reduced by connecting an additional diode in a back-to-back orientation (cathode to cathode or anode to anode). This results in a cancellation of distortion currents. The cancellation should be total, but the distortion produced by each PIN diode is not exactly equal in magnitude and opposite in phase. Approximately 20 dB distortion improvement may be expected by this back-to-back configuration.

Distortion in Attenuator Circuits

In attenuator applications, distortion is directly relatable to the ratio of RF to DC stored charge. In such applications PIN diodes operate only in the forward bias state, and often at high resistance values where the stored charge may be very low. Under these operating conditions, distortion will vary with charges in the attenuation level. Thus, PIN diodes selected for use in attenuator circuits need only be chosen for their thick I region width, since the stored charge at any fixed diode resistance, R_S , is only dependent on this dimension.

Consider an SMP1304-001 PIN diode used in an application where a resistance of 50 Ω is desired. The data sheet indicated that 1 mA is the typical diode current at which this occurs. Since the typical carrier lifetime for this diode is 1 μ S, the stored charge for the diode at 50 Ω is 1.0 nC. If two PIN diodes, however, are inserted in series to achieve the same 50 Ω resistance level, each diode must be biased at 2 mA. This results in a stored charge of 2 nC per diode, or a net stored charge of 4 nC. Thus, adding a second diode in series multiplies the effective stored charge by a factor of 4. This would have a significant positive impact on reducing the distortion produced by attenuator circuits.

Measuring Distortion

Because distortion levels are often 50 dB or more below the desired signal, special precautions are required in order to make accurate second and third order distortion measurements. One must first ensure that the signal sources used are free of distortion and that the dynamic range of the spectrum analyzer employed is adequate to measure the specified level of distortion. These requirements often lead to the use of fundamental frequency band stop filters at the device output, as well as preselectors to clean up the signal sources employed. In order to establish the adequacy of the test equipment and signal sources for making the desired distortion measurements, the test circuit should be initially evaluated by removing the diodes and replacing them with passive elements. This approach permits one to optimize the test set-up and establish basic measurement limitations.

Since harmonic distortion appears only at multiples of the signal frequency, these signals may be filtered out in narrow band systems. Second order distortion, caused by the mixing of two input signals, will appear at the sum and difference of these frequencies and may also be filtered. As an aid to identifying the various distortion signals seen on a spectrum analyzer, it should be noted that the level of a second distortion signal will vary directly at the same rate as any change of input signal level. Thus, a 10 dB signal increase will cause a corresponding 10 dB increase in second order distortion.

Third order intermodulation distortion of two input signals at frequencies F_A and F_B often produce in-band, nonfilterable distortion components at frequencies of $2F_A - F_B$ and $2F_B - F_A$. This type of distortion is particularly troublesome in receivers located near transmitters operating on equally spaced channels. In identifying and measuring such signals, it should be noted that third order distortion signal levels vary at twice the rate of change of the fundamental signal frequency. Thus, a 10 dB change in input signal will result in a 20 dB change of the third order signal distortion power observed on a spectrum analyzer.

Bibliography

1. Garver, Robert V., "Microwave Control Devices," Artech House, Inc., Dedham, MA., 1976.
2. Mortenson, K.E. and Borrego, J.M., "Design Performance and Application of Microwave Semiconductor Control Components," Artech House, Inc., Dedham, MA., 1972.
3. Watson, H.A., "Microwave Semiconductor Devices and Their Circuit Application," McGraw Hill Book Co., New York, NY., 1969.
4. White, Joseph F., "Semiconductor Control," Artech House, Inc., Dedham, MA., 1977.
5. G. Hiller and R. Caverly, "Distortion in PIN Diode Control Circuits," IEEE MTT Transactions, May, 1987.
6. G. Hiller and R. Caverly, "Establishing the Reverse Bias to a PIN Diode in a High Power Switch," IEEE MTT Transactions, Dec., 1990.

© Skyworks Solutions, Inc. All rights reserved.

射频和天线设计培训课程推荐

易迪拓培训(www.edatop.com)由数名来自于研发第一线的资深工程师发起成立,致力并专注于微波、射频、天线设计研发人才的培养;我们于 2006 年整合合并微波 EDA 网(www.mweda.com),现已发展成为国内最大的微波射频和天线设计人才培养基地,成功推出多套微波射频以及天线设计经典培训课程和 ADS、HFSS 等专业软件使用培训课程,广受客户好评;并先后与人民邮电出版社、电子工业出版社合作出版了多本专业图书,帮助数万名工程师提升了专业技术能力。客户遍布中兴通讯、研通高频、埃威航电、国人通信等多家国内知名公司,以及台湾工业技术研究院、永业科技、全一电子等多家台湾地区企业。

易迪拓培训课程列表: <http://www.edatop.com/peixun/rfe/129.html>



射频工程师养成培训课程套装

该套装精选了射频专业基础培训课程、射频仿真设计培训课程和射频电路测量培训课程三个类别共 30 门视频培训课程和 3 本图书教材;旨在引领学员全面学习一个射频工程师需要熟悉、理解和掌握的专业知识和研发设计能力。通过套装的学习,能够让学员完全达到和胜任一个合格的射频工程师的要求...

课程网址: <http://www.edatop.com/peixun/rfe/110.html>

ADS 学习培训课程套装

该套装是迄今国内最全面、最权威的 ADS 培训教程,共包含 10 门 ADS 学习培训课程。课程是由具有多年 ADS 使用经验的微波射频与通信系统设计领域资深专家讲解,并多结合设计实例,由浅入深、详细而又全面地讲解了 ADS 在微波射频电路设计、通信系统设计和电磁仿真设计方面的内容。能让您在最短的时间内学会使用 ADS,迅速提升个人技术能力,把 ADS 真正应用到实际研发工作中去,成为 ADS 设计专家...



课程网址: <http://www.edatop.com/peixun/ads/13.html>



HFSS 学习培训课程套装

该套课程套装包含了本站全部 HFSS 培训课程,是迄今国内最全面、最专业的 HFSS 培训教程套装,可以帮助您从零开始,全面深入学习 HFSS 的各项功能和在多个方面的工程应用。购买套装,更可超值赠送 3 个月免费学习答疑,随时解答您学习过程中遇到的棘手问题,让您的 HFSS 学习更加轻松顺畅...

课程网址: <http://www.edatop.com/peixun/hfss/11.html>

CST 学习培训课程套装

该培训套装由易迪拓培训联合微波 EDA 网共同推出,是最全面、系统、专业的 CST 微波工作室培训课程套装,所有课程都由经验丰富的专家授课,视频教学,可以帮助您从零开始,全面系统地学习 CST 微波工作的各项功能及其在微波射频、天线设计等领域的设计应用。且购买该套装,还可超值赠送 3 个月免费学习答疑...

课程网址: <http://www.edatop.com/peixun/cst/24.html>



HFSS 天线设计培训课程套装

套装包含 6 门视频课程和 1 本图书,课程从基础讲起,内容由浅入深,理论介绍和实际操作讲解相结合,全面系统的讲解了 HFSS 天线设计的全过程。是国内最全面、最专业的 HFSS 天线设计课程,可以帮助您快速学习掌握如何使用 HFSS 设计天线,让天线设计不再难...

课程网址: <http://www.edatop.com/peixun/hfss/122.html>

13.56MHz NFC/RFID 线圈天线设计培训课程套装

套装包含 4 门视频培训课程,培训将 13.56MHz 线圈天线设计原理和仿真设计实践相结合,全面系统地讲解了 13.56MHz 线圈天线的工作原理、设计方法、设计考量以及使用 HFSS 和 CST 仿真分析线圈天线的具体操作,同时还介绍了 13.56MHz 线圈天线匹配电路的设计和调试。通过该套课程的学习,可以帮助您快速学习掌握 13.56MHz 线圈天线及其匹配电路的原理、设计和调试...

详情浏览: <http://www.edatop.com/peixun/antenna/116.html>



我们的课程优势:

- ※ 成立于 2004 年,10 多年丰富的行业经验,
- ※ 一直致力并专注于微波射频和天线设计工程师的培养,更了解该行业对人才的要求
- ※ 经验丰富的一线资深工程师讲授,结合实际工程案例,直观、实用、易学

联系我们:

- ※ 易迪拓培训官网: <http://www.edatop.com>
- ※ 微波 EDA 网: <http://www.mweda.com>
- ※ 官方淘宝店: <http://shop36920890.taobao.com>